

This pdf of your paper in *Ships and Guns* belongs to the publishers Oxbow Books and it is their copyright.

As author you are licenced to make up to 50 offprints from it, but beyond that you may not publish it on the World Wide Web until three years from publication (February 2014), unless the site is a limited access intranet (password protected). If you have queries about this please contact the editorial department at Oxbow Books (editorial@oxbowbooks.com).

SHIPS & GUNS

*The sea ordnance in Venice and Europe
between the 15th and the 17th centuries*

edited by

Carlo Beltrame and Renato Gianni Ridella



Università
Ca' Foscari
Venezia



© Oxbow Books 2011

ISBN 978-1-84217-969-7

Contents

Preface (*Carlo Beltrame, Renato Gianni Ridella*).....vii

Introduction: Ships, Guns and Historical Archaeology (*Sauro Gelichi and Mauro Librenti*).....ix

Venetian Guns for and from the Sea

1. Morphology and constructive techniques of Venetian artilleries in the 16th and 17th centuries: some notes (*Marco Morin*)..... 1
2. Venetian ordnance in the shipwrecks of the Mediterranean and Atlantic Seas (*Carlo Beltrame*) 12
3. The race to big calibres during the first war of Morea and Sigismondo Alberghetti's guns of new invention (*Guido Candiani*) 23
4. Two Venetian swivel guns from the Messina Strait, Italy (*Rossella Scordato*)..... 28
5. A Venetian ship sunk in Cyrenaica at the beginning of the 18th century (*Sebastiano Tusa*).... 35

Italian Production of Naval Ordnance between the 15th and 17th Centuries

6. Genoese ordnance aboard galleys and merchantmen in the 16th century (*Renato Gianni Ridella*)..... 39
7. Bombards in Savona in the 15th and 16th centuries (*Furio Ciciliot*)..... 57
8. Guns and profit. Tuscan naval artillery in the 16th to 17th centuries (*Niccolò Capponi*) 60
9. Armed ships of the Post-Medieval period in Croatia (*Irena Radić Rossi*) 64

European Ordnance aboard the Ships (15th–17th Centuries)

10. Did naval artillery really exist during the Modern period? A brief note on cannon design (*Javier López Martín*)..... 73
11. Stowed or mounted: the Spanish Armada of 1588 and the strategic logistics of guns at sea (*Colin Martin*)..... 85
12. “A jewel of great value”: English iron gunfounding and its rivals, 1550–1650 (*Ruth R. Brown*) 98
13. Ships and guns of the Tudor Navy 1495–1603 (*Robert Douglas Smith*)..... 106
14. The British sea service mortars. Some notes on their evolution with particular reference to the drawings of Albert Borgard, c. 1700 (*Martino Ferrari Bravo*) 116
15. Sixteenth-century French naval guns (*Max Guérout*)..... 124

Venetian Ordnance in the Shipwrecks of the Mediterranean and Atlantic Seas

Carlo Beltrame

Introduction

An investigation of the evidence of Venetian wrecks, both from publications and from unpublished new discoveries, has allowed us to identify about thirteen wrecks containing ordnance, as well as some isolated guns. This work has received great help from Marco Morin and Renato Ridella who have introduced the author to the world of the historic artillery.

The wrecks are distributed right along the routes of the Serenissima Republic (Figure 2.1). Starting from Venice, where we find the so called “Glass wreck” and “Guns wreck” in the harbour entrance of Malamocco, we move to the Dalmatian coast where we find the Gnalic wreck. Continuing along the Croatian coast there are the Kolocep and the Palagruza islands wrecks which are the subject of a Unesco Research Project between the University Ca’ Foscari and the University of Zara, in collaboration with the Croatian Conservation Institute of Zagreb. In the Eastern Mediterranean we have recorded only the isolated finds from Haifa in Israel, but if we go back along the Italian coast we have to take account of the guns found near Crotone and the wreck of Torre Faro of Messina. In Sicily there is evidence of a ship sunk at Filicudi island and the written and iconographical records of guns being found at a shipwreck in Castellammare di Trapani.

Along the Lybic coast of the Cirenaica, an Italian team has recently documented the wreck of the Venetian vessel *Tigre*, sunk in 1705.

It is curious how many wrecks of Venetian ships are present in the Atlantic sea, along the coasts of Great Britain and Ireland. In the South of England we can mention the Teignmouth and the presumed Isle of Wight wrecks while further North we have the ships wrecked during the expedition of the *Spanish Armada*. These are the *Balancera* or *Balanzera* ship, better known as *Trinidad Valencera*, wrecked in Kinnagoe Bay and the *Labia* or *Lavia* ship sunk in the Sligo bay, both in Ireland.

Not all these wrecks can be identified with certainty as being Venetian and not all the findings of isolated guns can be definitely linked to wrecks.

This study can confirm that guns are the most important indicators of modern age wrecks. If indeed we exclude the *fusta* of Lazise where it is possible that there was contemporary salvage of the artillery in the 1509, and the medieval galley of Venice which probably predates the arrival of shipboard guns, all the wrecks of Venetian ships have ordnance on them.

The wrecks

The so-called “Glass wreck” was found off the entrance to the harbour of Malamocco by amateur divers. The site has been excavated by Marco D’Agostino and Idra company who recovered many blocks of raw glass and other objects, which could be attributed to a Roman wreck contaminating a more recent wreck (D’Agostino 2008). Other objects indeed would date the second wreck to, more or less, the beginning of the seventeenth century.

Two very similar iron swivel breech-loading guns (*petriere da mascolo*) have been found. A swivel mount and two removable chambers (*mascoli*), which could be used on these weapons, have been found near them. Some stone shot and two wedges are other artefacts related to artillery. It is interesting to note that while the wedge of the elongated shape can be associated with this type of *petriera da mascolo*, the wedge with a merlon shape had to be used with a *petriera da braga*; as well documented by Moretti (1672, figs. 8, 9) and also by other archaeological findings.

The so called “Guns wreck” was found in the opposite side of the harbour entrance of Malamocco. The shipwreck can be dated to between the end of the XVII and the beginning of the XVIII century (D’Agostino, Galletta, Medas 2010). It contained four cast-iron guns of both Venetian and English production, but the finding of a breech chamber gives testimony to the ship being armed with swivel guns, too.

The site excavated near the small island of Gnalic, south of Biograd, is one of the most impressive wrecks of the Mediterranean both for the number and for the quality of the objects and for their condition and preservation. Although

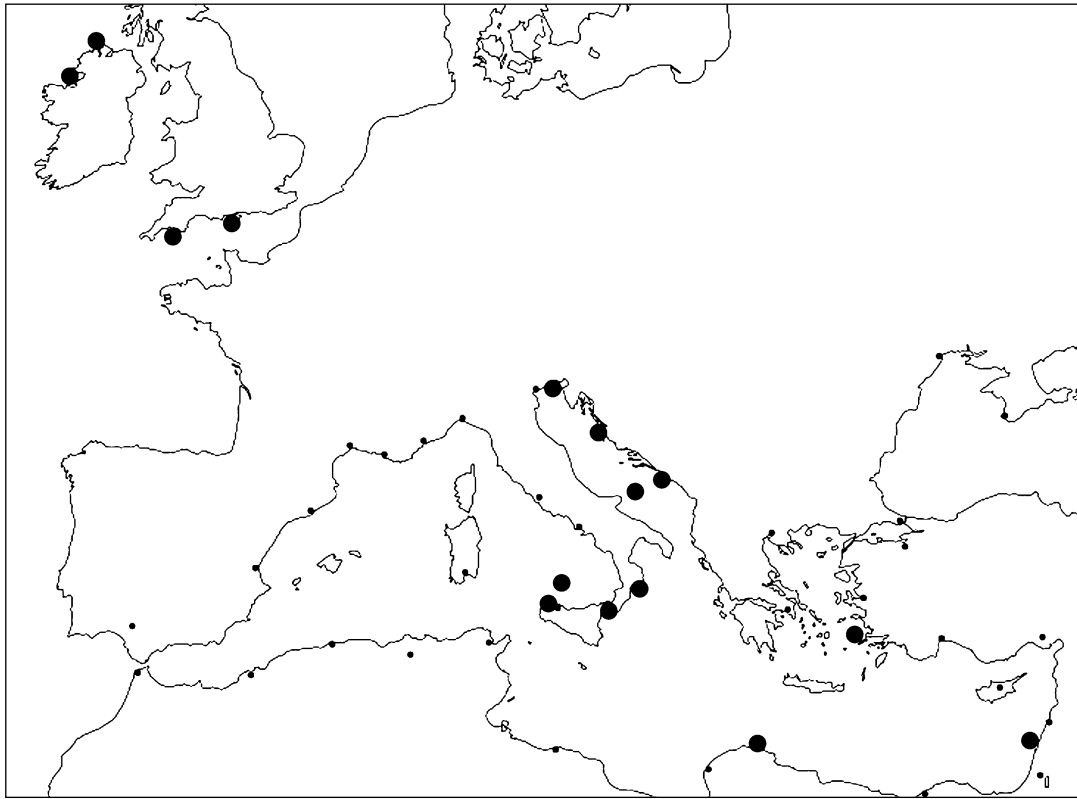

Figure 2.1. Map of distribution of Venetian wrecks.

it has been interpreted as a Venetian galley, we have demonstrated that it must have been a round ship, about 40 m long. The type of anchors, the cargo, the thickness of the frames, together with the types of artillery recovered, is proof of this assertion (Beltrame 2006).

The cargo was composed mainly of thousands of beautiful glass vessels perhaps from Murano, windowpanes, mirrors and semifinished metals (Lazar and Willmott 2006). Indeed, the ship carried brass leafs and wire and lead ingots in wooden barrels (Kelez 1970). Hundreds of spectacles, shaving razors and parts of chandeliers, perhaps made in Lübeck, were also part of the cargo (Stadler 2006). Damask and linen shirts were contained in a chest (Davanzo Poli 2006). Various objects relating to the commercial activities and the life aboard complete the diverse list of artefacts recovered (Petricioli S. 1970).

The artillery, studied by Ivo Petricioli (1970) and Marco Morin (2006), is composed of eight guns. There are two bronze *12 libre* sakers, 350 cm long and with a calibre of 9 cm (Tab. 1.1); at the breech, the numbers 2360 and 2380 respectively have been engraved to indicate the weight in Venetian *libre grosse*. The Roman numbers and the Z and A initials indicate that they were cast by *Zuane Alberghetti* II in 1582 (Figure 2.2).

The ship also carried three bronze *12 libre petriere da braga*, where the *braga* is in very corroded iron or absent. An empty coat of arms and the shape of one swivel gun are very similar to pieces in the Naval museum in Istanbul. The C which is present on another piece could have been cast by a member of the famous *di Conti* family of Venetian



Figure 2.2. Detail of a bronze saker cast by *Zuane Alberghetti* found in the *Gnalic wrecks* (photo by the author).



Figure 2.3. Detail of a bronze petriera da braga cast by a member of the Di Conti family found in the Gnalic wrecks (photo by the author).

founders (Figure 2.3). The fourth small piece is a bronze one *libra moschetto* with a curious coat of arms – perhaps of French origin. The same coat of arms is on a big gun signed with an A of the Alberghetti in the Askeri museum of Istanbul.

The last two pieces are two bronze minions (heavy falcons), called in Venetian terminology *9 libre passavolanti*, about 260 cm long with a calibre of 8 cm and of possible French origin (Morin 2006; Ridella 2007).

All the pieces had to be for private customers because of the absence of the winged lion and X symbol of the *Consiglio dei Dieci* magistracy, usually found on guns cast for the state until 1587.

The wreck also contained a wooden stopper from a breech chamber, slow match, two stone and one iron shot and a bronze gunner's rule very similar to other artefacts found on the wreck of the *Trinidad Valencera*, that is the Venetian *Balancera*.

The ordnance of the wreck would suggest that the ship sunk at the end of the 16th century.

In the waters of the island of Palagruza (ancient Pelagosa) two bronze guns and a bell have been recovered from a wreck. One gun is 260 cm long and bears a coat of arms with a cross, which belongs to the *Gritti* family of Venice, and the initials AL and G (Table 2.1: 2). The rich decoration, which, because is very similar to that one on a piece signed by CAMILLI ALBERGETI and made for a member of the *Gradenigo* family exhibited outside the Askeri museum of Istanbul (reg. n. 266), seam, in our opinion, a style typical of this member of the family of founders, who worked in Venice between 1517 and 1528 (Morin 1992, 781), and the other initials C and A on the gun allow us to attribute this object to this artist.

The second gun is about 2 m long and bears the same coat of arms of the *Gritti* family except for the T and C

initials of *Tomaso di Conti* who was active, according Avery (2003, 249), in the 1520s–1530s (Table 2.1: 3). The same s-faceted surface is visible on a big piece decorated with a lion and signed with a T and a C and on an other big piece decorated with a lion and the coat of arm of a member (A...) of the *Gradenigo* family and signed with a T and a C in the Askeri museum of Istanbul (reg. n. 405, 408). This manufacturing seams typical of this founder.

Given the working dates of the two founders, the likeliest candidate for the initials AL-G is *Alvise Gritti* (better known as *Ludovico*), son of the doge *Andrea*, a famous and wealthy merchant and politician in his own right. In the 1520s he lived in Constantinople as a trader and in the 1530s he was involved in the politics in Hungary where he was murdered in 1534 (Nemeth Papo and Papo 2002). In the 1520s he was involved in the export of tin for the Turkish gun foundries (Nemeth Papo and Papo 2002, 30–31).

Since Alvise was an illegitimate son of the doge and so he was not a *patrizio*, it may seem strange that he was able to mark his guns, cast in Venice, with his father's coat of arms and initials. Because a brief research in the Archivio di Stato di Venezia (for example: ASV, M. Barbaro, *Arbori de patritii veneti*, VI, c. 473) has allowed many other members of the Gritti family candidates to be recognised from the initials AL-G, some as *Alessandro* and some *Alvise Gritti*, the problem of the identification is still open and would need a long and complex investigation.

The ship that was wrecked near the island of Kolocep was probably trying to enter the harbour of Ragusa, that is, the ancient Dubrovnick. It carried hundreds of bottles and vessels (Radic Rossi 2006) and some pottery dating the wreck to the beginning of the 17th century but generically not of Venetian production (S. Gelichi, pers. comm.).

Together with some metal objects, three bronze *petriere da mascolo* have been recovered by amateur divers (Table 2.3: 1). The only one the author has been able to document belongs to a type which is found over a wide geographical spread and that, thanks to a comparison with two pieces on display in the Naval Museum of Venice, suggests they could have been produced in Venice. Indeed, both these two *petriere* show the *Lion in moeca* of Venice; the gun on the left has got the monogram of the *Alberghetti* family while that on the right bears the initials of *Marcantonio di Niccolò di Conti*. The latter, since it was recovered by a fisherman off Chioggia, must have been on a ship (Avery 2005, 442).

The F and M initials engraved on the coat of arm on the chase of both the Kolocep piece and of an artefact from the Naval museum of Istanbul, belong to the owner of the ship.

At least three iron guns are still on the seabed of Kolocep but because of the concretion covering their surface we have been not able to identify them.

In 1973, off Haifa or Athlit, a fisherman recovered a bronze saker 340 cm long and with a calibre of 9 cm (Roth 1989). The initials Z and A and the style of the decorations, similar to those present on the pieces from the wrecks of Gnalic and the *Balancera*, allow us to attribute it to *Zuane*

Table 2.1: 1. Bronze culverin-saker from the Gnalic wreck (Croatia) cast by Zuane Alberghetti (after Petricioli, I, 1970, fig. 11), 2. Bronze gun from the wreck of Palagruza (Croatia) cast by Camillo Alberghetti (courtesy Irena Radic) 3. Bronze gun from the wreck of Palagruza (Croatia) cast by Tomaso di Conti (courtesy Irena Radic), 4. Bronze saker from Haifa (Israel) cast by Zuane Alberghetti (after Roth 1989, fig. 1).

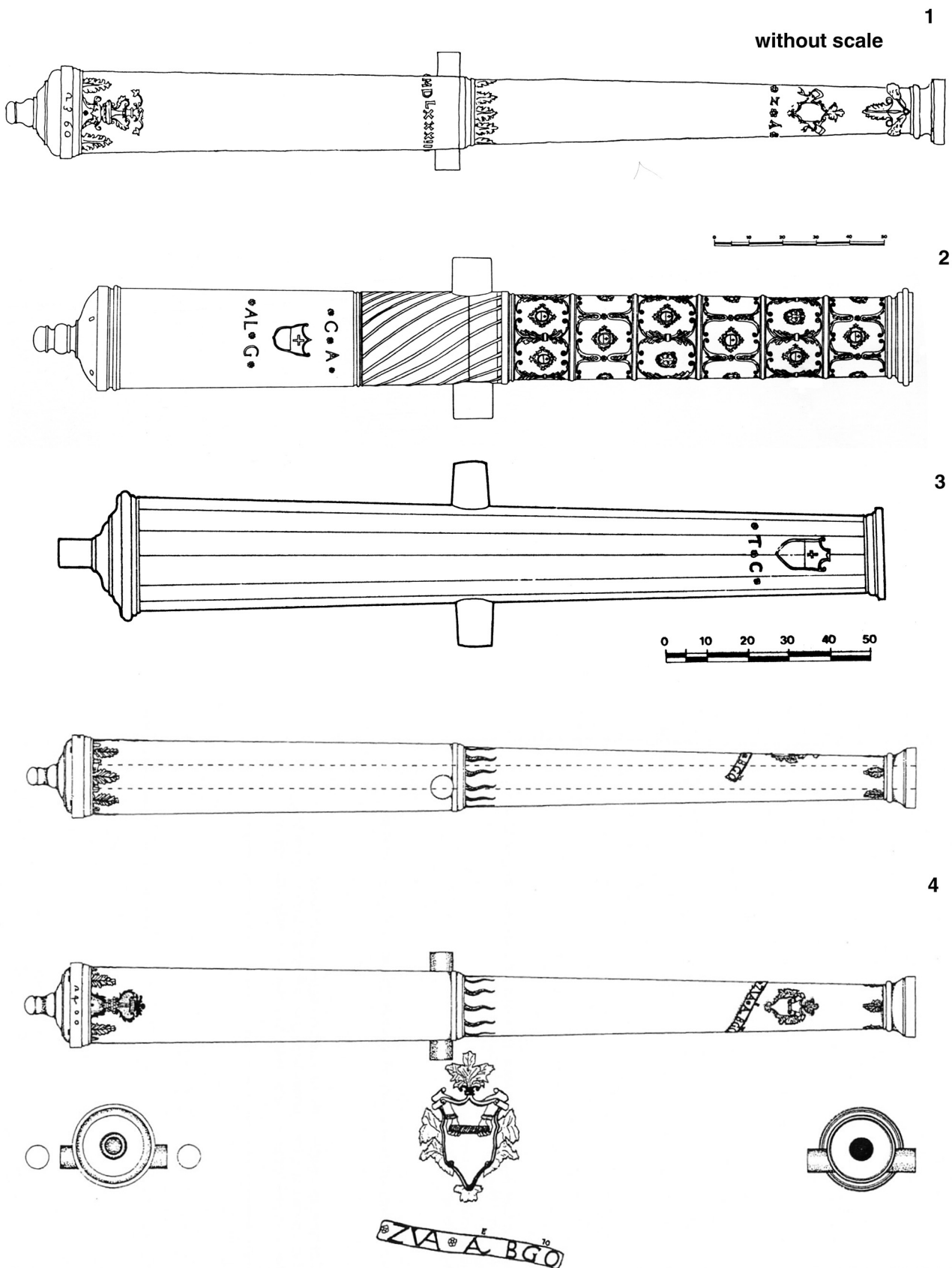

Table 2.2: 1. A bronze falconetto found off the Isle of Wight (England) made by Zuane Alberghetti (after Tomalin, Cross and Motkin 1988, fig. 2), 2. Bronze saker from the wreck of Teignmought (England) made by Sigismondo Alberghetti (after Dudley 1989, fig. 1), 3. Bronze falconetto from the wreck of Teignmought (England) made by Sigismondo Alberghetti (after Preece and Burton 1993, fig. 13), 4. Bronze culverin from the wreck of the Trinidad Valencera (Balancera) cast by Niccolò di Conti (after Martin and Parker 1999, 272) 5. Bronze saker from the wreck of the Trinidad Valencera (Balancera) cast by Zuane Alberghetti (after Martin and Parker 1999, 272).

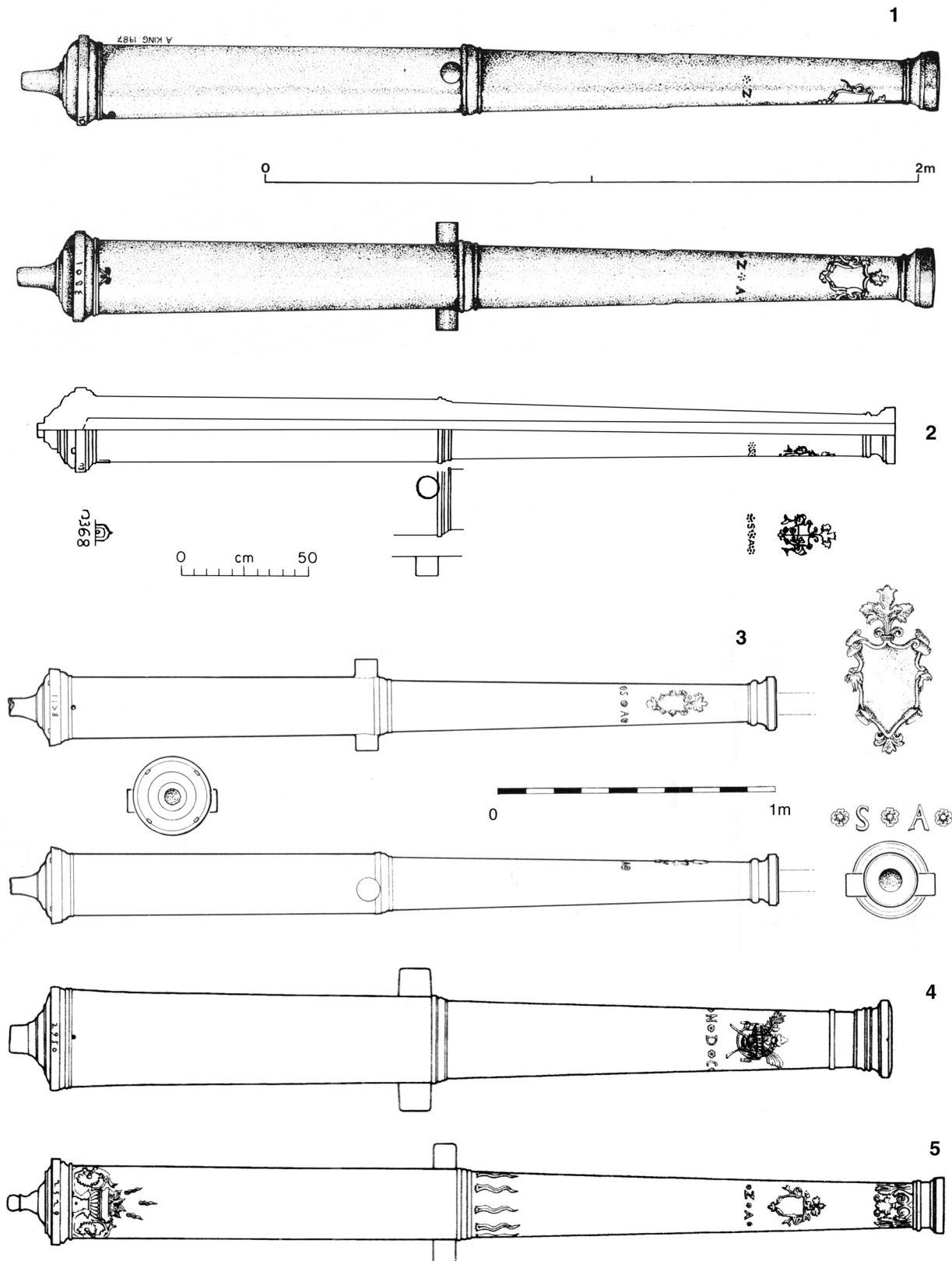

Table 2.3: 1. Bronze petriera da mascolo from the wreck of Kolocep (Croatia) (drawing by Elisa Costa), 2. Bronze and iron petriera da braga from the wreck of the Trinidad Valencera (Balancera) (after Martin and Parker 1999, 273), 3. Bronze and iron petriera da braga from the wreck of the Labia (after McElvogue 2002, 41), 4. Bronze and iron petriera da braga from the wreck of Teignmouth (England) (after Preece and Burton 1993, fig. 14).

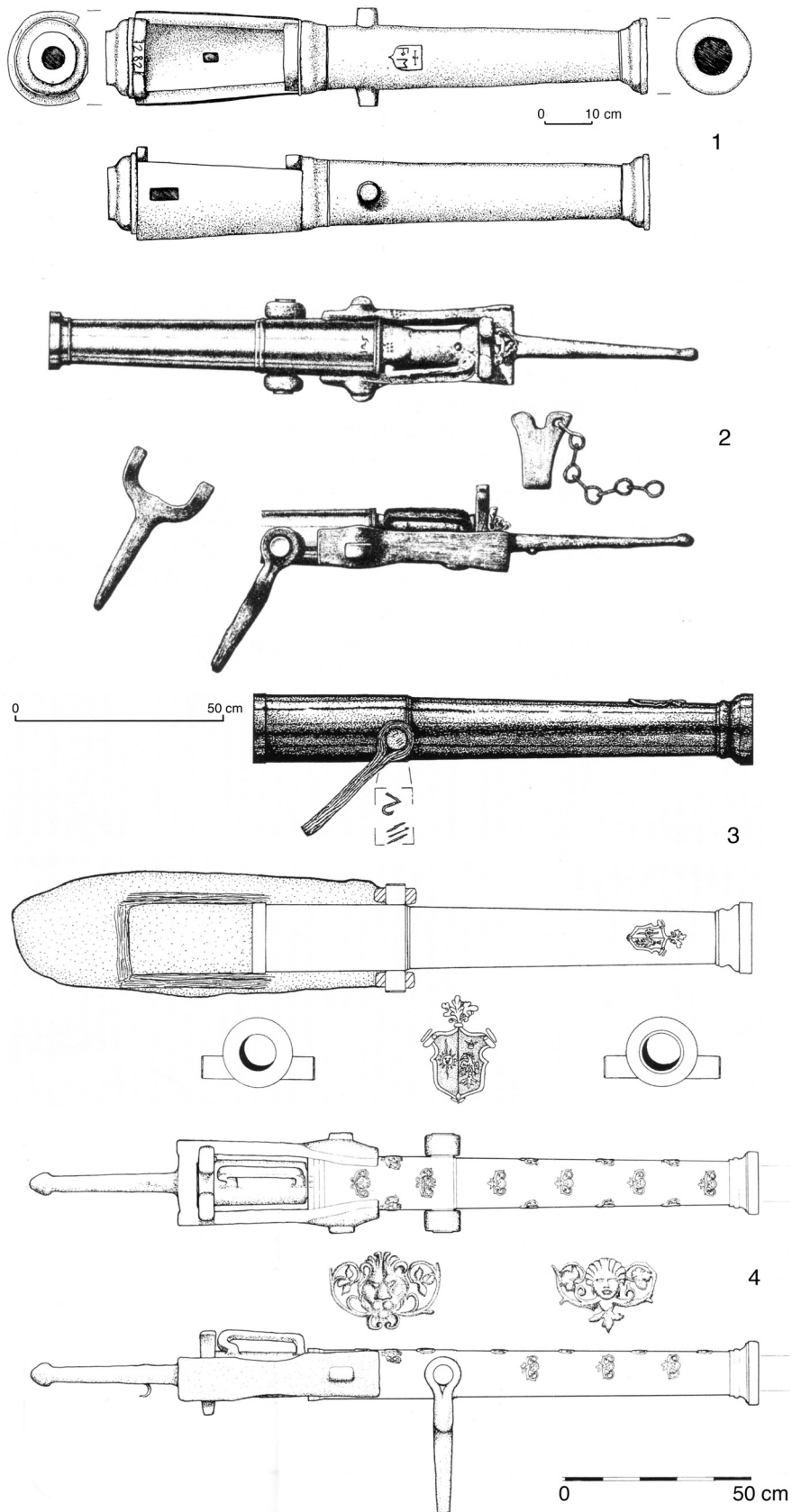



Figure 2.4. (Left), Two bronze falconetti or falconi found near Crotona (photo by the author with the permission of the Civic Museum of Crotona). (Right), Detail of one of the falconetti from Crotona cast by Marco di Conti. The X of the Consiglio dei Dieci is present.

Alberghetti the second, active, according to Morin (1992, 782) between 1573 and 1586 (Table 2.1: 4).

In the sixties of the 19th century, sponge-divers saw about forty bronze guns off the Isle of Symi in Greece. Nine of them had been raised; at the artillery museum of Woolwich, in England, there are five of these objects: three guns, with a calibre of 9.5 cm and 202 cm long and two *petriere da mascolo*, with a calibre of 7.6 cm and 102 cm long. All the pieces showed the Lion *in moeca* which indicates that they probably belonged to a state, and to quite a big, vessel (Hewitt 1871).

In the civic museum of Crotona two bronze *falconetti* or *falconi* 154 cm long are on display (Figure 2.4). On the chase they show the Lion *in moeca*, the X belonging to the Council of Ten and the monograms M and C of *Marco di Conti I*, active in the Arsenal – according to Avery (2003, 249) – between 1526 and 1567. Seven bronze pieces signed with M and C are on display in the Askeri museum of Istanbul (reg. n. 255, 256, 280, 284, 286, 287, 297).

The long *petriera da mascolo* with the *mascolo* in the holder cannot be Venetian. The Turkish bronze gun with an Islamic Arab inscription could be evidence of a fight between a Christian and a Turkish ship west of Capo Colonna (Figure 2.5). The Lion and the X suggest that the two *falconetti* could have belonged to a galley.

Two bronze and iron *petriere da braga*, one bronze *mascolo* and fifteen stone and iron shot come from the sea of Torre Faro near Messina. The presence of other finds of probable Venetian origin suggest the existence of a wreck of a Venetian ship (Scordato in this volume).

The presence off Castellammare del Golfo di Trapani, at Magazzinazzi, of a shipwreck of a vessel carrying Venetian ordnance can also be documented from written and iconographic sources. A manuscript from Palermo dating to 1703 (Palazzolo 2007, 72), (brought to my attention by Renato Ridella), records the recovery of a bronze gun, probably belonging to a wreck, with two coats of arms and the image of Santa Caterina in correspondence with the trunnions (Figure 2.6). The dolphin, on one of the coat of arms, would indicate that the owner of the piece was a member of the Venetian family *Dolfin* while the Roman numerals and the inscription OPUS ALBERGETI tell us that it was cast by one of the *Alberghetti* family in 1547.

The ordnance on display at the archaeological museum of Lipari has been officially attributed to the wreck of an 18th-century Spanish vessel at Capo Graziano on Filicudi Island (Kapitaen 1985). Thanks to Ridella's communication and the kind collaboration of the archaeologists at the museum, we have been able to make a preliminary study of the pieces. These are a bronze *falconetto* (Figure 2.7), 2 m long with a calibre of 6.5 cm, and two bronze *petriere da braga*. An empty shield and the monogram N and C on the *falconetto* suggests it was cast by the founder *Niccolò di Conti II* who, according to Avery (2003, 249), was active between 1559 and 1601 (Figure 2.8). Three pieces of artillery signed by this founder are in the Askeri museum of Istanbul (reg. n. 132, 275, 397).

The two bronze *petriere da braga*, which are lacking the *braghe*, are 150 cm long and have calibres of 9 and 9.5 cm. Some common pottery, a copper cauldron, some bricks



Figure 2.5. Turkish bronze gun with Arab inscription found near Crotone.

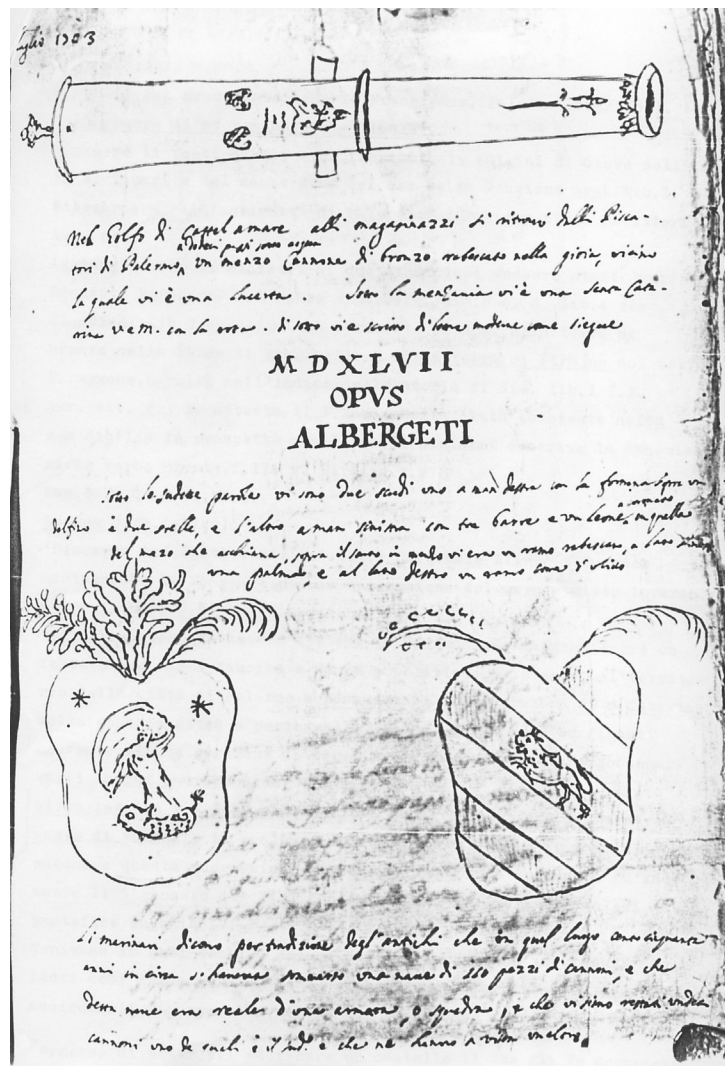

Figure 2.6. Manuscript from the Archivio di Stato di Palermo, dating in the 1703, which records the recovery of a bronze gun at Castellammare di Trapani. The dolphin, on one of the coat of arms, indicates the Venetian family Dolfin while the inscription tells that it was cast by an Alberghetti in 1547 (courtesy Antonino Palazzolo and Gianni Ridella).



Figure 2.7 (above). A bronze falconetto and two bronze petriere da braga in the Archaeological Museum of Lipari (photo: Marcello Consiglio, with the permission of the Direction of the museum).



Figure 2.8 (left). An empty shield and the monograms N and C, on the falconetto made by Niccolò di Conti the second (photo: Marcello Consiglio, with the permission of the Direction of the museum).

the written sources (ASV, Senato, Dispacci, Provveditori di terra e da mar, filza 1341) it carried 48 bronze guns, 12 swivel guns and 22 iron guns but only the last have been found on the site (Tusa in this volume).

Exiting beyond the Pillars of Hercules, there are three or four wrecks of Venetian ships.

In the South of England, at Teignmouth, from 1975 to 1995, a group of sport divers excavated a site and recovered hundreds of artefacts relating to life aboard ship and its equipment, as well as items for the defence of the ship. These included 120 pieces of iron and stone shot and two *mascoli* for the various pieces of artillery recovered. These include a bronze saker with the monogram S and A and a shield showing a lion rampant and a wheel (Dudley 1989; Preece and Burton 1993; Wilson 1993; Preece 2004) (Table 2.2: 2). While of course the wheel has to belong to the Venetian family *Molin*, we can only suppose that the lion belonged to the *Badoer* family.

The same monogram S and A (belonging to the founder *Sigismondo Alberghetti*) is on two bronze *falconetti* one of which was still attached to a fragment of the carriage (Table 2.2: 3). It is probable that the guns, which are decorated with a mute coat of arm, were made by *Sigismondo II*, active perhaps from 1566 to 1610 (Morin 1992, 783), although we cannot exclude completely *Sigismondo I* or *Sigismondo III*. In the Askeri museum of Istanbul there are ten pieces signed with S and A (reg. n. 260, 268, 269, 274,

and a millstone come from the site where it appears that anchors and iron guns have also been seen in the past.

The *Tigre* vessel was intentionally sunk by its captain on 7 April 1705 to avoid it being captured by enemies along the coast of the Cirenaica at Ras al-Hilal. According to

276, 290, 298, 299, 301, 378) and the piece number 276 shows the same mute coat of arm visible on the *falconetti* from Teignmouth.

The three *petriere da braga* are beautifully decorated with heads of cherubins and heads of lions and at least one is complete with its *mascolo* and its *cuneo* to stop it (Table 2.3: 4). We do not know who produced these pieces, but we can notice that the cherubins are a motif also used by *Marcantonio di Conti* – who worked from the end of the 16th century to 1638 (Avery 2005) – on some of his productions.

Another bronze *falconetto*, also with a fragment of its carriage, has been found off the Isle of Wight (Tomalin, Cross and Motkin 1988) (Table 2.2: 1).

The monograms Z and A and the style, which is very similar to that one of the pieces of Gnalic and of the *Balancera*, suggests it was more likely to have been cast by *Zuane Alberghetti II*, active from 1573 to 1586 when he was put in jail (Morin 1992, 782), rather than *Zuane Alberghetti I*. The gun could be associated to a wreck under preliminary investigation containing North Italian pottery as well (Watson and Gale 1990; Advisory Committee on Historic Wrecks Sites 2005).

We want to conclude our *excursus* on the Venetian wrecks with the evidence of the two ships that took part at the expedition of the Spanish Armada in the Levant Squadron after they had been commandeered, at Lisbon, by Phillip II. With the *Ragazzona*, which sunk off Corunna in December 1588 (Martin and Parker 1999, 244; ASV, Archivio notarile Catti, reg. 3360, fol. 86 (21 March 1589)), the Venetian ships in the fleet were reduced to three. In addition to the *Ragazzona*, which was the flag ship of the Levant Squadron, there was the *Balancera*, possibly owned by *Alvise Balancer*, a merchant active at the end of the 16th century (Tenenti 1959, 113). This *Balancera* was renamed *Trinidad Valencera* by the Spaniards and was rated at 1100 tons (Martin and Parker 1999, 23–24). Furthermore, there was the *Lavia* or *Labia*, rating at 728 tons (Martin and Parker 1999, 263; AGS CS 2a leg. 280: f. 12), which took the name of the family of the wealthy merchant *Paolo Antonio Labia* (Birch 2004, 15; AGS CS 2a leg. 280: f. 12; ASV, archivio notarile Catti reg. 3360, fol. 34, 1 February 1589). Although these ships had been armed with additional guns and munitions in Lisbon, the equipment and the original artillery aboard were Venetian.

The *Balancera*, which was wrecked in Kinnagoe bay in Ireland, has been excavated by Colin Martin (1979) who recovered, together with elements of the equipment and objects for the life aboard, a gunner's rule (Rodríguez-Salgado 1988, 180; Martin 1997, 5–13) – very similar to the one from Gnalic but made of wood rather than bronze – and also four pieces of ordnance. These were a bronze saker, 345 cm long with a calibre of 9 cm, made by *Zuane Alberghetti II* (Table 2.2: 5), a bronze culverin, 325 cm long with a calibre of 11.8 cm (Table 2.2: 4), a bronze falcon, 292 cm long with a calibre of 7.2 cm, made by *Niccolò di Conti II* and then a bronze *petriera da braga* with the iron *braga* (Rodríguez-Salgado 1988, 177–178; Martin and Parker 1999, 272–274; Martin in this volume)

(Table 2.3: 2). The falcon presents a decoration similar to that one on a piece signed with ND and C and dated 1539 in the Askeri museum of Istanbul (reg. n. 132).

The *Labia*, sunk in the Sligo Bay in Ireland, has been the object of a non-disturbance survey by an English team (Birch and McElvogue 1999; Birch 2004). From the site, a bronze *petriera da braga* with a calibre of 9 cm has been recovered. The eagle on its coat of arms is the symbol of the *Labia* family (Table 2.3: 3).

Two guns (probably bronze), with their perfectly-preserved carriages, have been left *in situ* and are waiting for the continuation of the research on this very promising site (Birch and McElvogue 1999; McElvogue 2002; Birch 2004, 183–212).

Conclusions

As a conclusion to this brief overview of the Venetian wrecks, we can say that it is impressive how many they are when compared to those of other states

Thus we also have many more Venetian guns to study, in comparison with guns from other states especially in the Mediterranean area. This result can be only partially explained by the attention that the Venetian wrecks have received in comparison with those of other states. The Venetian ships are well attested in the Adriatic, in the central Mediterranean and in the Atlantic in a quite limited period, between the latter half of the 16th century and the first twenty years of the 17th century. The *Tigre* ship and the “Guns wreck” of Malamocco, sunk in the beginning of the 18th century, are the only exceptions. This result itself is interesting but perhaps need to be verified through the collection of more data.

Considering that most of the ordnance does not bear the image of the lion, symbol of the government ownership, it seems that many Venetian wrecks belong to private, round ships; the only evidence of guns made for the State, that is with the image of the lion, come from Croton, Symi, Cirenaica and the “Guns wreck” of Malamocco.

In conclusion, the archaeological evidence confirms what we know from the written sources – that in this period, the monopoly of bronze artillery production belongs to the *di Conti* and *Alberghetti* families. From the sea, eight pieces made by the *di Conti* have been recovered and ten made by the *Alberghetti* family of which the largest single number are those cast by *Zuane* the second. This evidence would confirm the impression that the *Alberghetti* family was little more productive than the *di Conti* one that we have had registering 35 pieces, signed with the typical A, and only 21, signed with the typical C, in the Askeri museum of Istanbul.

Nautical archaeology also allows us to state that, curiously, as the wrecks of the *Balancera*, of Palagruza and perhaps of Gnalic indicate, it was quite common for a ship to carry guns cast by both the families, that is to say that the quality of their production had to be very similar. But only further marine discoveries of guns will be able to confirm this and the other preliminary considerations.

References

- Advisory Committee on Historic Wrecks Sites (2005) *Annual Report 2005*. Department of Culture, Media and Sport. London.
- Avery, V. J. (2003) State and Private Bronze Foundries in Cinquecento Venice: New Light on the Alberghetti and di Conti Workshops. In P. Motture (ed.) *Large Bronzes in the Renaissance*, Symposium Papers XLI (Studies in the History of Art, 64), 241–276, New Haven-London.
- Avery, V. (2005) >>giovane di spirito e d'ingegno<<: New Light on the Life and Work of the Venetian Renaissance Bronze Caster Marcantonio di Niccolò di Conti (1576–1638). In M. Gaier, B. Nicolai, T. Weddigen (eds.) *Der unbestechliche Blick. Festschrift zu Ehren von Wolfgang Wolters zu seinem siebzigsten Geburtstag*, 438–463. Trier.
- Beltrame, C. (2006) Osservazioni preliminari sullo scafo e l'equipaggiamento della nave di Gnalic. In Gustin, M., Gelichi, S., Spindler, K. (eds.) *The heritage of the Serenissima. The presentation of the architectural and archaeological remains of the Venetian Republic, proceedings of the international conference, Izola-Venezia 2005*, 93–95. Koper.
- Birch, S. (2004) *The Streedagh Armada Wrecks. Historical background and site report for the Spanish Armada wrecks of la Lavia, la Juliana and Santa Maria de Vison 1982–2002*. Unpublished report.
- Birch, S., McElvogue, D. M. (1999) *La Lavia, La Juliana and the Santa Maria de Vison: three Spanish Armada transports lost off Streedagh Strand, The International Journal of Nautical Archaeology*, 28.3, 265–276.
- D'Agostino, M. (2008) Il relitto del Vetro di Venezia. Alcune considerazioni per una rilettura cronologica. In L. Fozzati, C. Pizzinato (eds.) *Malamocco. Studi di Archeologia Lagunare e Navale*, 145–153. Venezia.
- D'Agostino, M., Galletta, G., Medas, S. (2010), Il relitto “dei cannoni” di Malamocco, Venezia. In S. Medas, M. D'Agostino, G. Caniato (eds.) *Navis. Archeologia, Storia, Etnologia, Atti del I Convegno Nazionale, Cesenatico 2008, Bari*, 63–70.
- Davanzo Poli, D. (2006) I reperti tessili di Gnalic. In Gustin, M., Gelichi, S., Spindler, K. (eds.) *The heritage of the Serenissima. The presentation of the architectural and archaeological remains of the Venetian Republic, proceedings of the international conference, Izola-Venezia 2005*, 98–99. Koper.
- Dudley, E. R. (1989) Alberghetti Guns, *The International Journal of Nautical Archaeology*, 18.3, 268.
- Hewitt, J. (1871) Venetian bronze guns recovered by divers in the Mediterranean, *Archaeological Journal*, 28, 305–308.
- Kapitaen, C. (1985) Capo Graziano. Relitto E: nave da guerra del XVIII secolo. In L. Bernabò Brea, M., Cavalier (eds.) *Archeologia subacquea nelle Isole Eolie. Archeologia Subacquea 2 (Bollettino d'Arte 29 Suppl.)*, 98–99.
- Kelez, I. (1970) O sirovinama, *Vrulje*, 1, 40–45.
- Lazar, I., Willmott, H. (2006) *The glass from the Gnalic wreck*. Koper.
- Martin, C. J. M. (1979) *La Trinidad Valencera: an Armada invasion transport lost off Donegal, The International Journal of Nautical Archaeology*, 8, 13–38.
- Martin, C. J. M. (1997) *Ships as integrated artefacts: the archaeological potential*. In M. Redknap (ed.) *Artefacts from Wrecks*, 1–13. Oxford, Oxbow.
- Martin, C., Parker, G. (1999) *The Spanish Armada* (revised edition). Third edition, Manchester, Mandolin.
- McElvogue, D. M. (2002) A description and appraisal of ordnance from three Spanish Armada transports c. 1588, *Journal of the Ordnance Society*, 14, 31–50.
- Moretti, T. (1672) *Trattato dell'artiglieria*. Brescia.
- Morin, M. (1992) Alberghetti. In K. G. Saur (ed.) *Allgemeines Kuenstlerlexicon. Die bildenden Kuenstler aller Zeiten und Voelker*, 2, 779–784. Muenchen-Leipzig.
- Morin, M. (2006) Le artiglierie del relitto di Gnalic. In Gustin, M., Gelichi, S., Spindler, K. (eds.) *The heritage of the Serenissima. The presentation of the architectural and archaeological remains of the Venetian Republic, proceedings of the international conference, Izola-Venezia 2005*, 95–97. Koper.
- Nemeth Papo, G., Papo, A., 2002, *Ludovico Gritti. Un principe-mercante del rinascimento tra Venezia, i turchi e la corona d'Ungheria*. Venezia.
- Palazzolo, A. (2007) *Le torri di deputazione nel Regno di Sicilia (1579–1813)*. Istituto Siciliano Studi Politici ed Economici, Palermo.
- Petricioli, I. (1970) Sidra i topovi. *Vrulje*, 1, 9–15.
- Petricioli, S. (1970) Vaga i utezi. *Vrulje*, 1, 37–39.
- Preece, C. (2004) Evidence for high status at sea: the Church Rocks wreck, *Proceedings of the Devon Archaeological Society*, 62, 99–119.
- Preece, C., Burton, G. (1993) Church Rocks, 1975–83: a reassessment, *The International Journal of Nautical Archaeology*, 22.3, 257–265.
- Radic Rossi, I. (2006) Il relitto di una nave mercantile presso l'isola di Kolocep. In Gustin, M., Gelichi, S., Spindler, K. (eds.) *The heritage of the Serenissima. The presentation of the architectural and archaeological remains of the Venetian Republic, proceedings of the international conference, Izola-Venezia 2005*, 85–90. Koper.
- Ridella, R. G. (2007) Two 16th century Papal esmerils in the Cleveland Museum of Art, Ohio, and some notes on bronze pieces of ordnance with a polygonal section. *Journal of the Ordnance Society*, 19, 5–38.
- Rodriguez-Salgado, M. J. (ed.) (1988) *Armada 1588–1988. An international exhibition to commemorate the Spanish Armada*. London, National Maritime Museum.
- Roth, R. (1989) Two sakers from Israel, *The International Journal of Nautical Archaeology*, 18.1, 61–66.
- Stadler, H. (2006) The brass candlesticks, sconces and chandeliers from Gnalic wreck. In Gustin, M., Gelichi, S., Spindler, K. (eds.) *The heritage of the Serenissima. The presentation of the architectural and archaeological remains of the Venetian Republic, proceedings of the international conference, Izola-Venezia 2005*, 107–109. Koper.
- Tenenti, A. (1959) *Naufrages, Corsaires et Assurances maritimes à Venise 1592–1609*. Paris, S.e.v.p.e.n.
- Tomalin, D., Cross, J, Motkin, D. (1988) An Alberghetti bronze minion and carriage from the Yarmouth Roads, Isle of Wight, *The International Journal of Nautical Archaeology*, 17.1, 75–86.
- Watson, K., Gale, A. (1990) Site evaluation for maritime sites and monuments records: the Yarmouth Roads Wrecks investigations, *The International Journal of Nautical Archaeology*, 19.3, 183–192.
- Wilson, V. (1993) *The Story of Teignmouth's mysterious wreck* (Teignmouth collector series, book 1). Teignmouth.

Archival sources

- M. Barbaro, *Arbori de patritii veneti*, VI, c. 473, Archivio di Stato di Venezia.