

SEMINARI DEL CENTRO INTERUNIVERSITARIO  
PER LA STORIA E L'ARCHEOLOGIA DELL'ALTO MEDIOEVO

3

FROM ONE SEA TO ANOTHER  
TRADING PLACES IN THE EUROPEAN  
AND MEDITERRANEAN EARLY MIDDLE AGES

PROCEEDINGS OF THE INTERNATIONAL CONFERENCE  
COMACCHIO 27TH-29TH MARCH 2009

EDITED BY SAURO GELICHI AND RICHARD HODGES



BREPOLS

CLAUDIO NEGRELLI

Towards a definition of early medieval pottery: amphorae and other vessels in the northern Adriatic between the 7<sup>th</sup> and the 8<sup>th</sup> centuries

Studies of early medieval pottery, particularly trade vessels, have received scant attention by comparison with the strong tradition of studies focused on Late Antique ceramic production. Studies of early medieval wares in the north-western Adriatic area, on which my paper will focus, are no exception to this general picture. The development of research aimed at the analyses of the early medieval contexts permits now for the first time to define some new pottery markers, as well as to reconsider the importance of old and recent recoveries. Venice and Comacchio, belonging to the post-Roman era, occupy here a significant role in this review, however places with their origins in antiquity also are important.

*The amphorae*

Amphorae, unglazed and glazed wares, *pietra ollare*, glass vessels: these are the classes which best represent the early medieval period between the 7<sup>th</sup> and the 9<sup>th</sup> centuries.

The circulation of the early medieval amphorae, defined as globular after the Aegean LR2 amphorae, feature prominently in the new foundations in the Venetian lagoon and the Po delta area. This is due to two reasons: first, places were important centres of trade, and second, the well stratified levels are not compromised by residual material from the Roman period.

Widespread between the 7<sup>th</sup> and the beginning of the 9<sup>th</sup> century, the globular amphorae occur in several fabrics and as well as a morphological variety. This variability has led us to suppose the presence of many centres of production, and therefore of a great variety of imports reaching the northern Adriatic region.

In 2004 when we started to study these wares on the bases of the finds from Comacchio, the chronological range of the archaeological contexts was still very limited<sup>1</sup>. Now with the start of the project focussed upon

<sup>1</sup> For a general overview see: C. Negrelli, «Produzione, circolazione e consumo tra VI e IX secolo: dal territorio del padovetere a Comacchio» in *Genti nel Delta da Spina a*



1. Comacchio, Piazza XX Settembre. Samos Cistern  
Type *amphora* from a 7<sup>th</sup>-century layer.

early medieval Comacchio<sup>2</sup> we have been able to recover new and important stratigraphic sequences at the excavations in the Piazza XX Settembre (adjacent to the Cathedral), and in the northern area of Comacchio (Villaggio S. Francesco, the site of the early medieval port).

The evidence from the Piazza XX Settembre excavation consists of a series of occupation levels including a workshop for iron and glass manufac-

*Comacchio. Uomini, territorio e culto dall'Antichità all'Altomedioevo*, eds. F. Berti, M. Bollini, S. Gelichi e J. Ortalli, Ferrara, 2007, p. 437-472; for the site reports from Comacchio see: S. Gelichi, C. Negrelli, G. Bucci, V. Coppola, C. Capelli, «I materiali da Comacchio», in *Genti nel Delta da Spina a Comacchio. Uomini, territorio e culto dall'Antichità all'Altomedioevo*, eds. F. Berti, M. Bollini, S. Gelichi e J. Ortalli, Ferrara, 2007, p. 601-648.

<sup>2</sup> For overviews see S. Gelichi, D. Calaon, E. Grandi, C. Negrelli, «“...Castrum igne combussit...”: Comacchio tra tarda antichità ed alto medioevo», *Archeologia Medievale*, XXXIII (2006), p. 19-48; S. Gelichi, D. Calaon, E. Grandi, S. Lora, C. Negrelli, «Uno scavo scom-



2. Comacchio, Piazza XX  
Settembre. Small-sized  
*spathion* from a  
7<sup>th</sup>-century layer.

posto. Un accesso alla storia di Comacchio attraverso le indagini presso la cattedrale», in *Missioni archeologiche e progetti di ricerca e scavo dell'Università Ca' Foscari – Venezia* (Atti della VI Giornata di Studio), ed. S. Gelichi, Venezia, 2008, p. 159-166; S. Gelichi, D. Calaon, E. Grandi, C. Negrelli, «Il quartiere episcopale di un emporio altomedievale. Gli scavi nel centro storico di Comacchio e la sequenza dei materiali», in *L'archeologia dei paesaggi costieri e le variazioni climatiche. Il Progetto Interreg Italia Slovenia Alto Adriatico* (Atti del Convegno di Trieste), eds. R. Auriemma, S. Karinja, Trieste, 2008, p. 416-426; S. Gelichi (ed.), *L'isola del vescovo. Gli scavi archeologici intorno alla Cattedrale di Comacchio*, Firenze, 2009.

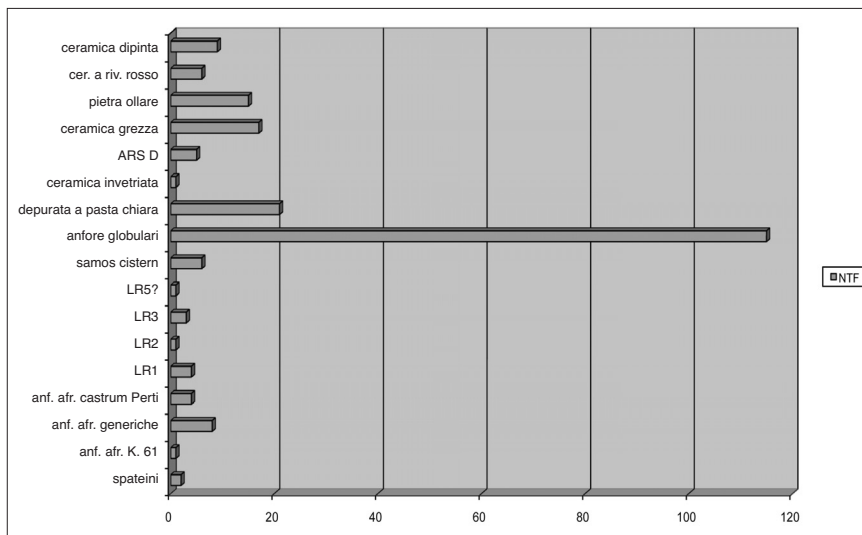

3. Comacchio, Piazza XX Settembre. Period 8, 7<sup>th</sup> century.  
Quantitative graphic of amphora sherds.

ture dating from the 7<sup>th</sup> century. The amphorae classes common among the Late Antique Mediterranean in the later periods are present here in small quantities. These include the *Samos cistern* type (fig. 1), the LRA 3 micaceous small amphorae and the LRA 1 for the eastern Mediterranean (with other sporadic evidence, as well as some fragments of LRA 2). African imported Late Antique wares are rare: there are fragments which could be part of the Key LXXI, of some small *spathia* (fig. 2) and above all of amphorae with a umbonal base.

During the 7<sup>th</sup> century, associated with the Late Antique types described above, early medieval globular amphorae occur for the first time (fig. 3). These consist mainly of sherds characterised by variable fabrics, often of a micaceous type and with bodies characterised by decoration with incised and distinct lines (fig. 4). When these vessels occur in small sherds they can be readily confused with Yassi Ada 2b<sup>3</sup> types, or with

<sup>3</sup> G. F. Bass, F. H. Van Doorninck, *Yassi Ada, Volume I. A Seventh-Century Byzantine Shipwreck*, College Station (Texas), 1982, p. 159-160: compare with CA 20 in particular. These vessels occur along with the latest phase of LRA 2 and coincide with the types which D. Pieri, *Le commerce du vin oriental à l'époque byzantine (V<sup>e</sup>-VII<sup>e</sup> siècles). Le témoignage des amphores en Gaule*, Beyrouth, 2005, p. 88-89, identifies with the variant LRA 2C, which can be ascribed to the 7<sup>th</sup> century. In reality the distinction between them is not clear, as little is known about their production places.

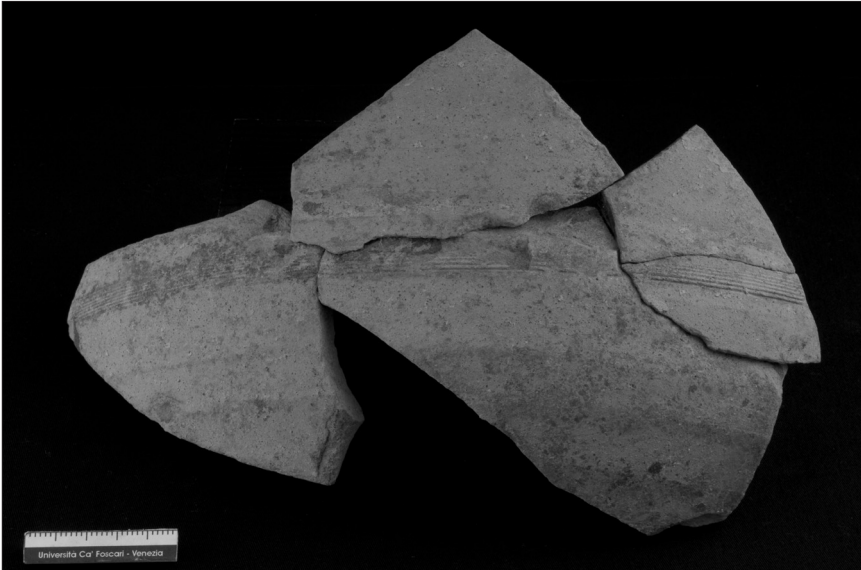

4. Comacchio, Piazza XX Settembre. Globular amphora showing rows of incised lines.

the vessel types with longer bodies, such as those ascribed to a Cypriote production centre as well as to Aegean 7<sup>th</sup>-century products (LRA 13)<sup>4</sup>. In Italy the incised decoration on globular amphorae is very distinctive, as in the case of vessels from Naples, Rome and also S. Antonino di Pertini. All of these can be dated at least from the late 7<sup>th</sup> to early 8<sup>th</sup> century and often ascribed to eastern Aegean production centres<sup>5</sup>. Actually from

<sup>4</sup> S. Demesticha, «Some thoughts on the production and presence of the late Roman Amphora 13 on Cyprus», in *Trade Relations in the Eastern Mediterranean from the Late Hellenistic Period to Late Antiquity: The Ceramic Evidence* (Acts Seminar - Sandbjerg Manorhouse, February 1998), eds. M. Berg Briese, L. E. Vaag, Odense M., 2005, p. 169-178 ascribes these wares to the more general Aegean environment of the LRA 13, eventually superceding the canonic productions LRA 2.

<sup>5</sup> For Naples see at least a vessel “highly micaceous” edited by P. Arthur, «Aspects of Byzantine Economy: an Evaluation of Amphora Evidence from Italy», in *Recherches sur la céramique byzantine* (Atti del Colloquio - Atene 1987) eds. V. Déroche, J.-M. Spieser, Atene, 1989, p. 84-85, fig. 5, from Santa Patrizia, in association with a 8<sup>th</sup>-century lamp; Rome, *Crypta Balbi*, the presence of micaceous amphorae, often decorated with lines of bands, beginning in the late 7<sup>th</sup> century, where they are correctly identified as eastern Mediterranean wares (for instance M.S. Arena, P. Delogu, L. Paroli, M. Ricci, L. Saguì, L. Vendittelli (eds.), *Roma dall'antichità al medioevo. Archeologia e storia nel*

Samos<sup>6</sup>, Chios<sup>7</sup>, Cos<sup>8</sup>, and from Constantinople<sup>9</sup>, Cyprus<sup>10</sup> and from Crete<sup>11</sup>, are very similar vessels which during the 7<sup>th</sup> century, superseded the types linked to the older LRA 2 types, produced in the same geographical area.

*Museo nazionale romano Crypta Balbi*, Roma, 2001, p. 288, cat. n. II.3.145); 8<sup>th</sup>-century globular vessels, almost the only amphorae of the era, have been treated with suspicion as their origins remain unknown and their source, while possibly in Italy, might as easily be in the Aegean or east Mediterranean. In this phase the decoration and lined surfaces have different characteristics, seemingly confined to the superior part of the shoulder: *Ibidem*, p. 505, cat. n. IV.5.13 e p. 506, cat. n. IV.5.16 (vessels of a probable Campania provenance). Furthermore, see D. Romei, «Produzione e circolazione dei manufatti ceramici a Roma nell'alto medioevo», in *Roma dall'antichità al medioevo II. Contesti tardoantichi e altomedievali*, eds. L. Paroli, L. Vendittelli, Roma, 2004, p. 279-285; in S. Antonino di Perti globular amphorae with decorations with incised lines are present among the vessels known as late variants of the LRA 2, in particular see G. Murialdo, «Le anfore da trasporto», in *S. Antonino. Un insediamento fortificato nella Liguria bizantina*, eds. T. Mannoni, G. Murialdo, Bordighera, 2001, p. 287, cat. n. 45, Tav. 17.2II, to be considered as 'un orizzonte produttivo orientale'. See also *ibidem*, p. 293, cat. n. 48a, tav. 18.22I, of insecure provenance.

<sup>6</sup> W. Hautumm, *Studien zu Amphoren der spätromisch und frühbyzantinischen Zeit*, Fulda, 1981.

<sup>7</sup> J. Boardman, «The Finds», in *Excavations in Chios 1952-1955. Byzantine Emporio*, eds. M. Ballance, J. Boardman, S. Corbett, S. Hood, Oxford, 1989, p. 86-142.

<sup>8</sup> N. Poulou-Papadimitriou, S. Didioumi, «Nouvelles données sur la production de l'atelier céramique protobyzantin à Kardamaina (Cos – Grèce)», in *LRCW 3, Late Roman Coarse Wares, Cooking Wares and Amphorae in the Mediterranean. Archaeology and Archaeometry* (Atti del Convegno, Parma-Pisa 2008), eds. S. Menchelli, S. Santoro, M. Pasquinucci, G. Guiducci, Oxford, 2010, p. 741-768.

<sup>9</sup> J. W. Hayes, *Excavations at Saraghane in Istanbul. Volume II, The Pottery*, Princeton, 1992, p. 71, especially types 29 e 36.

<sup>10</sup> S. Demesticha, «Amphora Production on Cyprus during the Late Roman Period», in *VIIe Congrès International sur la Céramique Médiévale en Méditerranée* (Thessaloniki 1999), ed. Ch. Bakirtzis, Atene, 2003, p. 469-476; S. Demesticha, «Some thoughts», p. 169-178.

<sup>11</sup> E. C. Portale, I. Romeo, «Contenitori da trasporto», in *Gortina V.3. Lo scavo del Pretorio (1989-1995), vol. V.3\* t.I. I materiali*, ed. A. Di Vita, Padova, 2001, p. 354, cat. n. 9; A. G. Yangaki, «Amphores crétoises de forme globulaire: remarques préliminaires», in *LRCW 2 Late Roman Coarse Wares, Cooking Wares and amphorae in the Mediterranean. Archaeology and Archaeometry*, II, eds. M. Bonifay, J.-Ch. Trégliat, Oxford, 2007, p. 767-774; N. Poulou-Papadimitriou, E. Nodarou, «La Céramique protobyzantine de Pseira: la production locale et les importations, étude typologique et pétrographique», in *LRCW 2 Late Roman Coarse Wares, Cooking Wares and amphorae in the Mediterranean. Archaeology and Archaeometry*, II, eds. M. Bonifay, J.-Ch. Trégliat, Oxford, 2007, p. 755-766.



5. Comacchio, Piazza XX Settembre. Period 7, 8<sup>th</sup> century.  
Globular amphorae sherds.

Some large wall fragments from the Comacchio sequence, from at least five individuals, can be ascribed to the types described above, that is the group of the late variants of the LRA 2, but the lack of other morphological markers leave this attribution still insecure, above all in relation to the early medieval globular amphorae common in the 8<sup>th</sup> century. Indeed, the body sherds and shoulder fragments of the vessels are reminiscent of an oblong body, rather than the globular form as in the case of the Yassi Ada 2b amphora type. The physical characteristics, with, frequently, abundantly micaceous fabrics, indicate the probability of products from the eastern Mediterranean, with particular links to the Aegean area and to the west coast of Anatolia<sup>12</sup>; though, we cannot exclude other elements as possible evidence of a source on the northern coast of the Black Sea<sup>13</sup>.

<sup>12</sup> The thin sections analysed by Claudio Capelli confirm this possibility.

<sup>13</sup> A.V. Sazanov, «Les amphores de l'antiquité tardive et du Moyen Age: continuité ou rupture? Le cas de la Mer Noire», in *Céramique Médiévale en Méditerranée* (Actes du VI<sup>e</sup> Congrès international sur la Céramique Médiévale en Méditerranée, Aix-en-Provence, 1995), Aix - en - Provence, 1997, p. 87-101.



In the following sequence<sup>14</sup>, based upon the development of a cemetery area next to Comacchio Cathedral, dating from the end of the 7<sup>th</sup> century at least until the beginning of the 9<sup>th</sup> century, globular amphorae can now be readily characterised by distinctive morphological elements (fig. 5). They often have short, slightly expanded rims, inner hollow, short conic necks and loop ribbed handles with an elliptical shape. It is more difficult to define the shape of the body, which could be mainly of a flaring form in its lower part. The phenomenon of the large numbers of these vessels is furthermore visible in the following stratifications, where the globular amphorae will be considered as residual evidence (9<sup>th</sup>-10<sup>th</sup>-centuries phases). In fact the problem of residuality and of the high level of fragmentation plays here an important role, as in the all urban excavations, in making it difficult to understand the temporal relationship between the early decorated vessels with bands of lines and the subsequent developments.

If we turn our attention to the other excavated areas in Comacchio, the port situated at Villaggio San Francesco produced a more complete picture in terms of forms, perhaps because this was an area devoted to trade in these goods. The materials of the emergency excavations of 1996 (fig. 6) and earlier discoveries<sup>15</sup> produced numerous example of amphorae characterised by tronco-conic necks, flat handles or large and/or slightly over reaching the rim, rounded shoulders, sometimes still characterised by incised bands of lines. Considering the better preserved examples, we have now globular amphorae fully comparable with the vessels of the 8<sup>th</sup>-century levels at Saraçhane – Istanbul<sup>16</sup> and also with forms widespread in several contemporary Italian contexts<sup>17</sup>.

The recent 2008-2009 excavations in the same area have produced a similar framework: fragments which seem to have body shapes very similar to the 8<sup>th</sup>-century types, that is with rounded shoulders and slightly flaring and straight walled bodies, ring foot bases, short tronco-conic necks and with an inner hollow on the lip.

<sup>14</sup> For the sequence see: S. Gelichi, D. Calaon, E. Grandi, S. Lora, C. Negrelli, «Uno scavo scomposto», p. 170-172; S. Gelichi (ed.), *L'isola del vescovo*, p. 44-47.

<sup>15</sup> C. Negrelli, «Produzione, circolazione», p. 454-468 for the general framework on the amphorae.

<sup>16</sup> See types 35-38 from Saraçhane: J. W. Hayes, *Excavations at Saraçhane*, p. 71, fig. 23.

<sup>17</sup> For a general overview of the Italian evidence of these vessels see: C. Negrelli, «Produzione, circolazione», p. 454-468, to add evidence from Classe (Ravenna): E. Cirelli, «Anfore globulari a Classe nell'alto Medioevo», in *V Congresso Nazionale di Archeologia Medievale*, eds. G. Volpe, P. Favia, Firenze, 2009, p. 557-562.

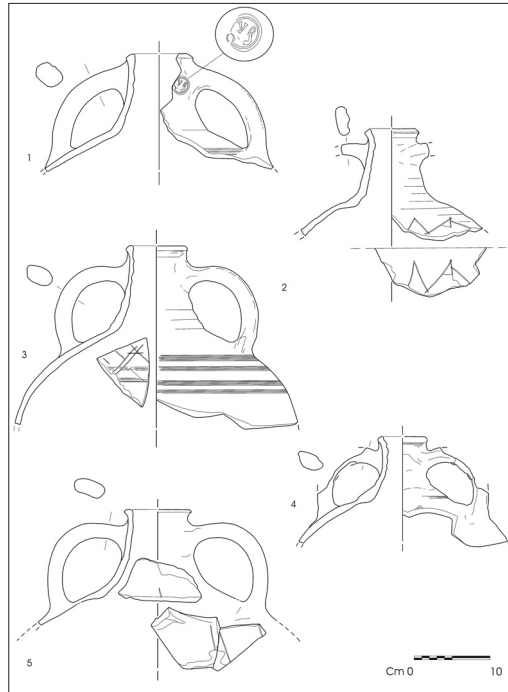

6. Comacchio, Villaggio San Francesco, 1996.  
Various types of globular amphorae.

The chronological determinations, awaiting further examination of the sequence, are however still preliminary. In fact we should not forget that the first indications of these wares occur in the 7<sup>th</sup> century<sup>18</sup>, and also that at Comacchio globular amphorae appear initially in association with other imported amphorae, such as the LR1 and the *Samos Cistern*, both dated to the 7<sup>th</sup> century<sup>19</sup>, and with the African wares, Keay LXI and LXII types<sup>20</sup>. We have however to stress that the links between the globular amphorae

<sup>18</sup> For the references, see *supra*.

<sup>19</sup> However on the later chronological limit of LR1 see P. Armstrong, «Trade in the east Mediterranean in the 8<sup>th</sup> century», in *Byzantine Trade, 4<sup>th</sup> – 12<sup>th</sup> Centuries. The Archaeology of local, regional and international exchange* (Atti del Simposio – Oxford 2004), ed. M. Mundell Mango, Oxford, 2009, p. 157-178, which consider them circulating in the whole early medieval period.

<sup>20</sup> For instance G. Murialdo, «Le anfore da trasporto», p. 291-293, Antonino 47 type. Also in this case it is important to stress that these are attested mainly between the mid and the late 7<sup>th</sup> century and may occur throughout much of the 8<sup>th</sup> century.

and the other amphorae ascribed to the 7<sup>th</sup> century were present only in the groups recovered during the old emergency excavations of the 1996, while in the excavations made between 2008-2009 (in the port), only early medieval globular vessels have been recovered. This might suggest that these recent excavations located an area of the port that was occupied from the 8<sup>th</sup> century onwards (fig. 7, Colour Plates). On the other hand on the south side of the 2008-2009 excavations, adjacent to the area identified as the port, at the beginning of the settlement sequence earlier material occurs. This consists of late forms of African Red Slip Ware, exclusively Hayes 105 dishes, in a series of variants which encompass the 7<sup>th</sup> century, though concentrating principally in the second half of the century<sup>21</sup>. The preservation of the amphorae does not permit us to precisely determine the typological characteristics of the first globular vessels, but probably these were more commonly decorated with bands of lines on their shoulders and walls.

We have to stress that during the later period several fragments (figs. 8-9) have short and slightly expanded externally rims, with an inner hollow, with short conical necks and invariably loop expanded ribbed handles of an elliptical shape. The bodies of these vessels have an oblong form towards the base.

Most of these amphorae are probably not of Italian origin (even if plausible) but either from the Aegean islands/ Anatolian coast of the Aegean<sup>22</sup>, or in certain cases the Black Sea area<sup>23</sup>. Concerning the content, the analyses by Alessandra Pecci have confirmed the presence of wine (tartaric acid) in one of the sampled base, and of oil, probably from olives, on a wall. In addition, on many of the body sherds are traces of resins.

Finally, the 2008-2009 archaeological sequence in the port area ends with amphorae and other materials which belong to the first half of the 9<sup>th</sup> century. The base of a small amphora characterised by an oblong shape is similar to those found in the Bozburun shipwreck<sup>24</sup> and in the

<sup>21</sup> Evidence of late variants of the Hayes 105 form (M. Bonifay, *Études sur la céramique tardive d'Afrique*, Oxford 2004, p. 183-185): variant A, dated to the end of the 6<sup>th</sup> -first half of the 7<sup>th</sup> century; variant B, dated to the mid of the 7<sup>th</sup> century; variant C, datable to the second half of the 7<sup>th</sup> century.

<sup>22</sup> These are the results of the analyses by Claudio Capelli. At the moment, however, we cannot be more precise, as the mineralogical studies of the fabrics of the Comacchio fragments is still in progress.

<sup>23</sup> This is the case for some fragments of lips and necks characterised by an inner hollow and by expanded handles with a slight central ribbing. See J. Vroom in this volume on the Crimean amphora found at Butrint.

<sup>24</sup> F.M. Hocker, «A Ninth – Century Shipwreck near Bozburun, Turkey», *INA Quarterly*, 22,1 (1995), pp. 12-14, class I.



8. Comacchio, Villaggio San Francesco, 2008-2009.  
Globular amphora from 8<sup>th</sup>-century layers.

Crimea<sup>25</sup>. The lack of materials datable to the 10<sup>th</sup>-11<sup>th</sup> centuries phase (for instance, coarse wares and sparse glazed wares) seems to strengthen the hypothesis that this sector of the port at Comacchio was not in use later than the 9<sup>th</sup> century.

In Venice the amphorae assemblage is similar, and confirms this outline assessment of the chronology and typology.

On the occasion of the re-examination of the Comacchio material from earlier excavations, we had suggested that the finds from Torcello may be similar. The Polish excavations at Torcello brought to light many fragments

<sup>25</sup> Y. Ivaschenko, «Les ateliers de céramiques du VI<sup>e</sup> au XV<sup>e</sup> s. au nord de la Mer Noire: le problème de la continuité», in *Céramique Médiévale en Méditerranée, Actes du VI<sup>e</sup> Congrès international sur la Céramique Médiévale en Méditerranée* (Aix – en – Provence, 1995), Aix-en-Provence 1997, pp. 73-85; A.V. Sazanov, «Les amphores», type n. 29.1, 30.2, 42.



9. Comacchio, Villaggio San Francesco, 2008-2009. Globular amphora from 8<sup>th</sup>-century layers.

of probable globular amphorae, particularly from the layers IV and V<sup>26</sup>. Although believed to date much earlier than is now thought to be the case, the presence of those vessels evidently became important from the time of the glass kiln (layer V), dated to the 9<sup>th</sup> century<sup>27</sup>, and in the layers in the

<sup>26</sup> L. Leciejewicz, E. Tabaczynska, S. Tabacziynski, *Torcello. Scavi 1961-1962*, Roma 1977, layer IV: p. 48, fig. 46, in particular 5-6 e 20-36, fig. 47 (some sherds of walls) e p. 55, fig. 51 in particular 47, 19 e 26; layer V, p. 62, in particular 33, 37-39 e p. 67 fig. 71.9-10, e p. 72 e fig. 75, 16-17, 20, 23, 27, refer to globular types, even if we cannot exclude that there could be more earlier wares, residual in this context associated with LR1 and LR 2. The provenance of these materials concerns respectively the layer IV and V. The finds were made “in the destroyed part of the tombs” or within the sectors without tombs. The chronology provided by the authors for these contexts concerns the 9<sup>th</sup>-10<sup>th</sup> centuries and furthermore seems to be significant in the same layer IV (but in the filling of the tombs 43-44). Here they have been recovered in association a Carolingian coin (AD 790-800) and an Arab dirham of the 8<sup>th</sup> and 9<sup>th</sup> centuries. In the subsequent excavations of 1983 similar elements were recovered in the layer IV, fig. 30.1,3-4. In a reappraisal aimed at clarifying the Late Antique phase, the problem of this layer has not been faced: I. Modrzewska, «Note sulle ceramiche tardo-romane dello scavo nell'isola di Torcello», in *Torcello. Nuove ricerche archeologiche*, a cura di L. Leciejewicz, Roma, 2000, p. 67-82. In layer V, associated with the glass workshop, are sherds both from the kiln, other structures and from the later fills. The kiln is dated to between the 7<sup>th</sup>-8<sup>th</sup> centuries and the beginning of the 9<sup>th</sup> century; while the C14, dating ascribes it to AD840.

<sup>27</sup> See the recent revision of the chronological issue by L. Leciejewicz, «Italian – Polish researches into the origin of Venice», *Archeologia Polona*, 40 (2002), p. 58; and

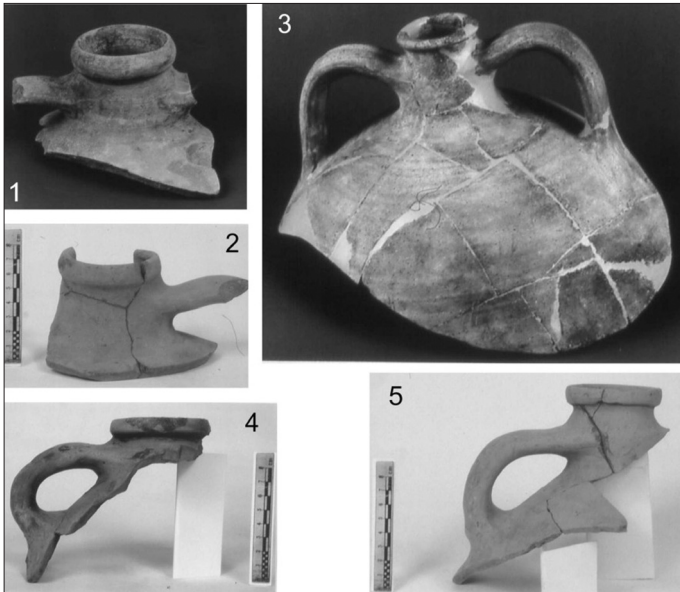

10. Venice, globular amphorae from various sites (from Toniolo, «Anfore dall'area lagunare»).

necropolis (layer IV, actually unrelated to the tombs, dated to the 9<sup>th</sup> and 10<sup>th</sup> centuries).

New investigations in the Venetian lagoon over the last 20 years have confirmed the circulation of the early medieval amphorae was quite frequent here (fig. 10). In S. Francesco del Deserto globular amphorae appear '... in filling layers laid down to contrast the maritime invasions...' and they seem to include fragments of different forms and fabrics<sup>28</sup>. Even if the ex-

the revision of the amphorae study by I. Modrzewska, «Note sulle ceramiche» which failed to address the problem of the early medieval wares, and instead focussed upon the 7<sup>th</sup>-century layers associated with the last Mediterranean wares belonging to the 7<sup>th</sup> century.

<sup>28</sup> M. Bortoletto, S. Spagnol, A. Toniolo, «Isole di San Francesco del Deserto e di Torcello. I reperti ceramici», in *Ritrovare restaurando. Rinvenimenti e scoperte a Venezia e in Laguna*, Cornuda (TV), 2002, p. 26 e 30, tav. 2, nn. 10, 11, 25; A. Toniolo, «Importazioni tra IV e VIII secolo d. C. nella laguna di Venezia», in *L'Archeologia dell'Adriatico dalla Preistoria al Medioevo* (Atti del Covegno – Ravenna 2001), ed. F. Lenzi, Firenze, 2003, p. 618; A. Toniolo, «Anfore dall'area lagunare», in *La circolazione delle ceramiche nell'Adriatico tra tarda antichità e altomedioevo* (Atti del III Incontro di Studio Cer.Am.Is.), eds. S. Gelichi, C. Negrelli, Mantova, 2007, p. 101.

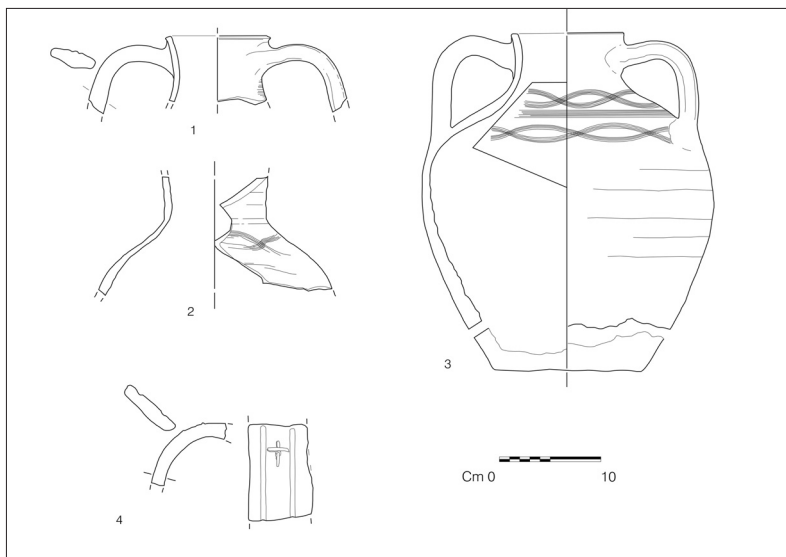

II. Comacchio, unglazed ware with incised wavy lines from various sites.

cavation sequence is only partially reassessed, it seems plausible to associate the earliest globular amphorae here with the latest African Red Slip wares<sup>29</sup>.

The most recent excavations of Santa Maria Assunta in Torcello confirm this, with the discovery of a big amphora fragment considered to be of 'Southern Adriatic' origin<sup>30</sup>. Furthermore, an important chronological element has now come to light with excavations underneath the church at Torcello. The amphorae of this type began to occur here after AD 681 (based upon the numismatic evidence) and before the construction of the fourth church nave<sup>31</sup>, essentially between the late 7<sup>th</sup> century and the first decades of the following century<sup>32</sup>.

<sup>29</sup> For the Red Slip Wares at San Francesco del Deserto: E. Grandi 2007, «Ceramiche fini da mensa dalla laguna veneziana. I contesti di S. Francesco del Deserto e Torcello», in *La circolazione delle ceramiche nell'Adriatico tra tarda antichità e altomedioevo* (Atti del III Incontro di Studio Cer.Am.Is.), eds. S. Gelichi, C. Negrelli, Mantova, 2007, p. 127-154.

<sup>30</sup> M. Bortoletto, S. Spagnol, A. Toniolo, «Isole di San Francesco», p. 26 e 34, Tav. 2, 10-25.

<sup>31</sup> A. Toniolo, «Anfore dall'area lagunare», p. 101.

<sup>32</sup> For a description of the excavation and the chronology of the sequence see M. De Min, «Edilizia ecclesiale e domestica altomedievale nel territorio lagunare. Nuovi dati conoscitivi da indagini archeologiche nel cantiere di restauro a Torcello», in *L'archeologia dell'Adriatico dalla Preistoria al Medioevo* (Atti del Convegno di Ravenna), ed. F. Lenzi, Firenze, 2003, p. 604.



12. Comacchio, Villaggio San Francesco, 2008-2009.  
Unglazed ware small amphora with incised wavy lines.

Further, new finds have been made at sites closer to the Rialto area. This is the case of the ex-cinema San Marco, where the 'globular amphorae are present in the reclamation layers deposited after the construction of a number of banks systems made with wood felled in the last 20 years of the 7<sup>th</sup> century (AD 687-688)', dates confirmed by Carbon 14<sup>33</sup>.

In the sequence of Ca' Vendramin Calergi excavation, along the Canal Grande north of the Rialto area, further elements provide some chronological definition. Here, in fact, early medieval amphorae fragments occur in the lowest stratigraphy<sup>34</sup> where Late Antique fine wares as well as African amphorae are almost completely absent unlike Torcello and San Francesco del Deserto<sup>35</sup>. Nevertheless, the chronology of the first phase here is dated to be-

<sup>33</sup> A. Toniolo, «Anfore dall'area lagunare», p. 101.

<sup>34</sup> For the sequence of the excavation of Ca' Vendramin Calergi: V. Gobbo, «Le ceramiche della prima fase medievale», in *Ca' Vendramin Calergi. Archeologia urbana lungo il Canal Grande di Venezia*, ed. L. Fozzati, Venezia, p. 43-57.

<sup>35</sup> For the 7<sup>th</sup>-century amphorae of African import from the ex-cinema San Marco see: A. Toniolo, «Anfore dall'area lagunare», p.100.



tween the 7<sup>th</sup> and the 8<sup>th</sup> centuries, due to the presence of LR 5-6 and LR 2. I think however that the lack of the Late African Slip Ware and of the African amphorae is a relevant chronological item, considering their distribution in the rest of the lagoon. A date in the 7<sup>th</sup> century is plausible, as in the case of the LR2, but we can see that the larger part of the occupation sequence, initially composed of a wooden building, belongs to the 8<sup>th</sup> century. The globular amphorae of Ca' Vendramin Calergi reflect, in terms of shapes, some common standards: narrow necks, elliptical or loop handles which sometimes are slightly high and with slightly expanded rims.

Other numerous globular amphorae finds have been recorded at Venice and from the Lagoon, most though are unpublished<sup>36</sup>: at Santa Maria Formosa, 'San Pietro di Castello', 'Teatro Malibran', 'San Lorenzo', 'Ca' Foscari', 'Fusina', 'canale di S. Antonio', 'canale di San Felice', 'Lazzaretto Nuovo', 'palude della Centrega', 'Punta Lunga and 'Vignole', 'Caorle' (probably). A preliminary examination of the materials discovered during some investigations carried out by the University Ca' Foscari seems to confirm a certain widespread distribution of the early medieval amphorae, as in the case of San Lorenzo di Ammiana and of S. Ilario<sup>37</sup>.

The parallel with the situation present at Comacchio is important:

- The first occurrence in the lagoon of globular amphorae seems to be associated with the latest phase of the African Red Slip Wares and African amphorae, as well as numerous Aegean and east Mediterranean vessels<sup>38</sup>.
- The morphological evolution of the amphorae in the lagoon shows, as in Comacchio, a decisive trend towards the types characterised by an inner hollow, with a strong everted rim on the outside<sup>39</sup>.
- The sources of the amphorae lie in the eastern and north-eastern Mediterranean, apart from a possible southern Adriatic type; it suggests, given the variability of fabrics present, a large number of centres of production<sup>40</sup>.

<sup>36</sup> Note the excavations mentioned by A. Toniolo, «Le anfore», in *Cà Vendramin Calergi. Archeologia urbana lungo il Canal Grande di Venezia*, ed. L. Fozzati, Venezia, 2005, p. 90.

<sup>37</sup> Research directed by Sauro Gelichi. About S. Ilario: D. Calaon, M. Ferri, C. Bagato, «SS. Ilario e Benedetto (IX secolo). Un monastero del nascente dogado veneziano tra terra e laguna», in *V Congresso Nazionale di Archeologia Medievale*, eds. G. Volpe, P. Favia, Firenze, 2009, p. 498-504. From San Lorenzo di Ammiana can be instead mentioned only few examples, dating to the late to early 8<sup>th</sup> centuries.

<sup>38</sup> In his summary A. Toniolo, «Anfore dall'area lagunare», describes 7<sup>th</sup>-century African amphorae: Keay 61A, 62A, Keay 8A, Cartagine 58, spatheini, spatheia, and Oriental amphorae LR 2, LR 2/13 (Yassi Ada type), LR 5-6.

<sup>39</sup> A. Toniolo, «Anfore dall'area lagunare», p. 101.

<sup>40</sup> M. Bortoletto, S. Spagnol, A. Toniolo, «Isole di San Francesco», p. 26 e 34, Tav. 2, 10-25; A. Toniolo, «Le anfore», p. 90; A. Toniolo, «Anfore dall'area lagunare», p. 101.

- The chronology seems to point towards the late 7<sup>th</sup> century, continuing uninterrupted until the 9<sup>th</sup> century.
- The number of examples increases in terms of quality and quantity, mostly occurring in the reinforcement of canal banks present in the commercial areas.

The last common pottery type shared by Comacchio and the early medieval lagoon is the so-called Unglazed Ware.

### *Unglazed Wares*

In Comacchio other ceramic types seem to be associated with the globular amphorae, notably the category of 'light clay unglazed ware' decorated with incised lines running in bands, as well as horizontal motifs sometimes taking a wavy form (figs. 11-13). Mostly these occur in closed shapes (open forms are rare) in different dimensions - small, medium and large. Among this latter are small amphorae of 30-40 cm in height, with ovoid bodies and flat bases, often in a poorly fired fabric yet clearly made by specialists<sup>41</sup>. In Comacchio Unglazed Wares are mainly present between the late 7<sup>th</sup> and early 9<sup>th</sup> centuries, often in association with the globular amphorae.

This association emerged clearly during the analysis of an assemblage found in 2003, located in the port area north of Comacchio, in which a number of deposits linked to a bank comprises principally these classes as well as *pietra ollare*. Red Slip Wares and the Late Antique amphorae were completely absent, as were Painted Wares. This, then, seems to be a post 7<sup>th</sup>-century deposit, characterized by the large variant of the Unglazed Wares in association with small amphorae<sup>42</sup>.

Recent excavations of the port area (Villaggio San Francesco, 2008-2009) and the excavation of Piazza XX Settembre further permitted the chronology of these wares to be more precisely dated. These wares enter in the sequence from the late 7<sup>th</sup> century, with medium closed shapes such as bottles (fig. 14, Colour Plates) and small amphorae (figs. 12-13). This chronology agrees with the small number of stratified finds discovered by the author elsewhere in the region: notably, the early medieval sequence at Rimini in the Piazza Ferrari excavations, where Unglazed Wares with incised wavy

<sup>41</sup> For the typological description see C. Negrelli, «Produzione, circolazione», p. 444-454.

<sup>42</sup> S. Gelichi, C. Negrelli, G. Bucci, V. Coppola, C. Capelli, «I materiali da Comacchio», in *Genti nel Delta. Da Spina a Comacchio. Uomini, territorio e culto dall'Antichità all'Alto-medioevo*, eds. F. Berti, M. Bollini, S. Gelichi, J. Ortalli, Ferrara, 2007, p. 614-621.



13. Comacchio, Villaggio San Francesco, 2008-2009.  
Unglazed ware sherd with incised wavy lines.

line decoration occurred between the end of the 7<sup>th</sup> and early 8<sup>th</sup> centuries<sup>43</sup>; and the sequence at the monastery of Nonantola, with similar wares dating from the 8<sup>th</sup> century<sup>44</sup>. It seems that the early wares possess these clear typological attributes, whereas during the 8<sup>th</sup> century a more standardised

<sup>43</sup> C. Negrelli, *Rimini Capitale. Strutture insediative, sociali ed economiche tra V e VIII secolo*, Firenze, 2008, p. 87-91.

<sup>44</sup> Unpublished materials from the Nonantola trenches carried out by the University Ca' Foscari of Venice – Insegnamento di Archeologia Medievale. The study is in progress, being carried out by Lara Sabbionesi, whom I thank for the information and a useful exchange of opinions.

product was made with a distinctly coarser, more poorly fired fabric. This may be related to an increase in the demand for these wares and a consequent increase in their production. In any case the characteristics of the fabrics remain to be understood. They are macroscopically uniform but probably can be readily differentiated with further analyses.

Despite the fact that their form and fabrics bear comparison with wares from Rome and Latium<sup>45</sup>, the mineralogical analysis shows these pots were not made there or indeed anywhere in the Tyrrhenian seaboard or indeed the southern Adriatic region. The fabrics suggest these wares were made locally or in the sub-region, though as yet precise evidence for this has yet to be found<sup>46</sup>.

These wares seem to be multifunctional vessels, but the large and medium vessels are often double handled and should be considered as flat based amphorae. So far analyses of the organic contents taken from a bottle recovered on a floor level related to the late phase of the wooden building of Piazza XX Settembre, dating to the late 7<sup>th</sup> century, showed that it had contained both oil and wine. However, it is not clear whether it was a table ware or a storage vessel<sup>47</sup>.

The problem of the larger double handled form has to be considered further. These vessels were recovered in significant quantities in the port areas, belonging to the largest size. Many vessels contain traces of impermeable resins, while a sort of constancy in size characterises a large part of the products. The larger among the small amphorae could contain about 12 litres, similar to the globular vessels of Yassi Ada, type 2, with a capacity of 13/14 to 20 litres<sup>48</sup>.

The context, the morphology and the capacity allow at least to hypothesize the following: the amphorae were used to transport liquid or semi-liquid goods, traded with the tools used for the fluvial and inner lagoon navigation.

Similar vessels appear also in Venice, for example at the excavation of Ca' Vendramin Calergi where the association of amphorae and unglazed wares found at Comacchio also occurs (fig. 15). Here, in the first phase, associated with a wooden structure, where both Red Slip Wares and Painted Wares are absent, the ceramic assemblage comprised LR 5/6, amphorae which are part of the LR2 group, and mainly sherds of globular amphorae as well as

<sup>45</sup> See among the substantial bibliography: D. Romei, «Produzione e circolazione».

<sup>46</sup> Analyses made by Claudio Capelli. See S. Gelichi, C. Negrelli, G. Bucci, V. Coppola, C. Capelli, «I materiali», p. 643.

<sup>47</sup> Analyses made by Alessandra Pecci.

<sup>48</sup> G.F. Bass, F.H. Van Doorninck, *Yassi Ada*, p. 161-162.

Unglazed Wares, mainly in medium and small sizes<sup>49</sup>. Here, though, *pietra ollare* is absent, while the coarse wares are really common (the opposite of the case at Comacchio).

An apparent more sporadic circulation seems to exist not only among the coastal cities, but also at inland sites. So, these occur on the central

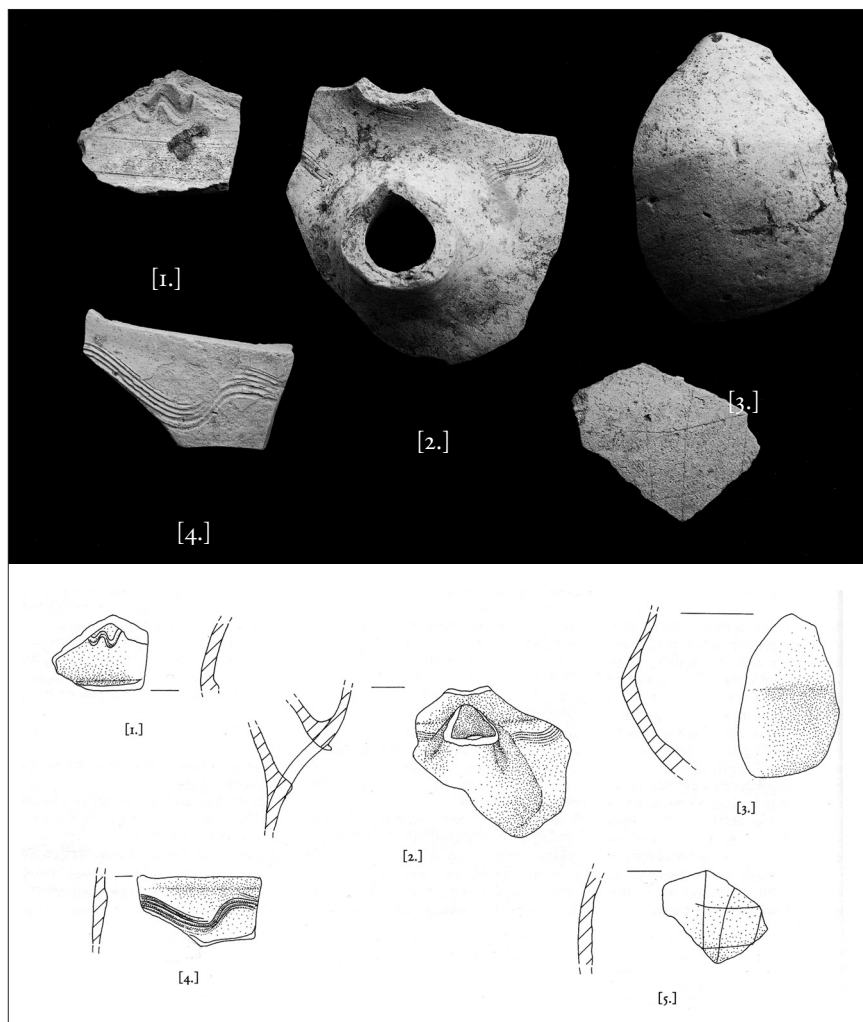

15. Venice, Ca' Vendramin Calergi. Unglazed ware with incised wavy lines (from Gobbo, 2005, «Le ceramiche della prima fase medievale»).

<sup>49</sup> V. Gobbo, «Le ceramiche della prima fase medievale», in *Cà Vendramin Calergi. Archeologia urbana lungo il Canal Grande di Venezia*, ed. L. Fozzati, Venezia, 2005, p. 95 e figs. 1-5.

Adriatic coast, as well as inland at Cesena<sup>50</sup> and, as we have seen above, Nonantola<sup>51</sup>.

We may speculate as to whether other examples exist in Northern Italy, unrecognized amongst the large numbers of residual Roman and Late Antique wares.

### *Questions and further study*

The association of globular amphorae and Unglazed Wares, begs the question as to whether these were complementary traded goods of some kind.

Many of the amphorae from Comacchio and the Venetian lagoon belong to an Adriatic distribution pattern which probably has its origins in either the Aegean or East Mediterranean. If at the moment it is still not possible to precisely indicate the exact origins of these wares, both the morphological elements and the first mineralogical analyses direct our conclusions towards these areas.

On the other hand, the vessels, often double handled, in Unglazed Wares reflect a production which seems aimed to satisfy a local use, as much as the needs of a major market centre. In these circumstances we might interpret the larger vessels as representing a type of simple transport amphorae designed for marine distribution by the rivers and within the lagoon.

It is clear that the meaning of these products can be included not only extending the research to make comparisons with other exchange places, but also through the analyses of further and important components of the framework. Accompanying these vessels were large numbers of *pietra ollare* jars at Comacchio, indicating a Po fluvial form of communication with the large cities of the *Regnum*. The presence of early medieval amphorae in places such as Verona and Brescia confirms this<sup>52</sup>. The old concept of an impermeable

<sup>50</sup> C. Negrelli, «I materiali ceramici tra Tardoantico e Medioevo», in *Ritmi di transizione. Il colle Garampo tra civitas e castrum: progetto archeologico e primi risultati*, eds. S. Gelichi, M. Miari, C. Negrelli, Firenze, 2009, p. 50.

<sup>51</sup> *Supra*.

<sup>52</sup> For Verona: G. Cavalieri Manasse, B. Bruno, «Edilizia abitativa a Verona», in *Abitare in città. La Cisalpina tra impero e medioevo* (Atti del Convegno), ed. J. Ortalli, M. Heinzelmann, Wiesbaden, 2003, p. 61 e fig. 10.9. V. also B. Bruno, «Ceramiche da alcuni contesti tardoantichi e altomedievali di Verona», in *La circolazione delle ceramiche nell'adriatico tra Tarda Antichità ed Altomedioevo* (3° Incontro di Studio Cer.am.Is sulle ceramiche tardoantiche ed altomedievali – Venezia 2004), eds. S. Gelichi, C. Negrelli, Mantova, 2007, p. 162 e Tav. 16, who stresses the lack of volcanic inclusions, which excludes a source in Campania and Latium; and B. Bruno, «Le anfore di media e tarda età imperiale di produzione italiana, egeo orientale, ispanica e anfore non identificate»,

frontier separating the territories in this region is no longer sustainable<sup>53</sup>, nor is it tenable to interpret the distribution of these wares as somehow supported by centralised redistribution<sup>54</sup>. Instead, we need to examine the real importance of the new indicators of trade in relation to the specific levels of the exchange and the nature of early medieval trading.

Compared to Late Antique wares, these early medieval vessels reflect a small volume of fluvial traffic. If instead we consider only the new contexts, where these wares are more visible because there is no likelihood of confusion with fragments of Late Roman wares, the framework changes. In those places where it is possible to make a comparison with the earlier phases of 6<sup>th</sup>-7<sup>th</sup> centuries, as at Comacchio, the quantities of ceramics appears to increase again during the 8<sup>th</sup> century. If this is accepted, it shows how important the ceramic products are as indicators for writing economic history. These markers, of course, bear witness to the traffic in amphorae but also perishable goods.

If Mediterranean contact beyond the Adriatic is in time confirmed by further research, it will be important to define the specific provenance of these products<sup>55</sup>, but also the maritime trade dynamics in relation to the

in *L'area del Capitolium di Verona. Ricerche storiche e archeologiche*, ed. G. Cavalieri Manasse, Verona, 2008, p. 382-383. For Brescia: B. Bruno, S. Bocchio, «Le anfore da trasporto», in *S. Giulia di Brescia, gli scavi dal 1980 al 1992. Reperti preromani, romani e alto medievali*, ed. G.P. Brogiolo, Firenze, 1999, p. 239-240, for probable Oriental imports, p. 241-243 for probable Italic-Adriatic imports.

<sup>53</sup> For instance, E. Zanini stresses the significance of the frontier separating the Byzantine and the Lombard worlds: «La ceramica bizantina in Italia tra VI e VIII secolo. Un sistema informativo territoriale per lo studio della distribuzione e del consumo», in *VII<sup>e</sup> Congrès International sur la Céramique Médiévale en Méditerranée* (Aiecm2 – Thessaloniki 11-16 Octobre 1999), ed. Ch. Bakirtzis, Athènes, 2003, p. 381-394.

<sup>54</sup> For example, S. Gelichi, «The Eels of Venice. The Long Eighth Century of the Northern Region along the Adriatic Coast», in *774. Ipotesi su una transizione*, ed. S. Gasparri, Turhout, 2008, p. 81-117; see also S. Gelichi, «L'archeologia della laguna veneziana e la nascita di una nuova città», in *Le trasformazioni dello spazio urbano nell'alto medioevo (secoli V-VIII). Città mediterranee a confronto*, eds. C.E. Méndez, S. Gasparri, *Reti Medievali Rivista*, XI (2010/2), p. 1-31. For a general view of the European and Mediterranean economic context, see M. McCormick, «Where do trading towns come from? Early medieval Venice and the northern emporia», in *Post Roman towns, trade and settlement in Europe and Byzantium; vol. 1: the heirs of Roman West: 41-68*, ed. J. Henning, Berlin - New York, p. 41-68.

<sup>55</sup> Cyprus, Crete, the northern Aegean and probably the Black Sea as well as the southern Italy are possible locations of possible imports, some having been transported by way of Constantinople.

routes and concomitant customs tolls. The recent excavation of early medieval amphorae in the destruction levels of one of the towers at Butrint in southern Albania provides a benchmark for a reconsideration of early medieval commerce in the entire Adriatic Sea region<sup>56</sup>. Butrint is not an isolated occurrence: recent research in Montenegro<sup>57</sup> as well as of other poorly published finds from this country<sup>58</sup> reveal a pattern of ceramic distribution encompassing the Dalmatian coast, and providing a connection to the northern Adriatic region.

How much of this trade, which seems to prefer coastal routes mainly based on the Balkan margins of the Adriatic Sea<sup>59</sup>, can be attributed to economic regionalised frameworks and more or less in communication between them<sup>60</sup>, and how much on the other hand can be attributed to routes which directly arrived at the northern-eastern coastline and which evidently had to include different products, besides wine or oil, might be clarified only as a result of more analytical, basic data examination.

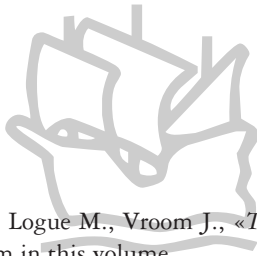

<sup>56</sup> R. Hodges R., Kamani S., Logue M., Vroom J., «*The sack of Butrint, c. AD 800*», *Antiquity*, 83 (2009); J. Vroom in this volume.

<sup>57</sup> Unpublished material in Bar museum and in other coastal localities of Montenegro, mostly derived from underwater discoveries (research in progress carried out by the Stari Bar – University Ca' Foscari of Venice project).

<sup>58</sup> Note R. Auriemma, E. Quiri, «La circolazione delle anfore in Adriatico tra V e VIII sec. d.C.», in *La circolazione delle ceramiche nell'adriatico tra Tarda Antichità ed Altomedioevo* (3° Incontro di Studio Cer.am.Is sulle ceramiche tardoantiche ed altomedievali – Venezia 2004), eds. S. Gelichi, C. Negrelli, Mantova, 2007, p. 42, see for instance S. Gluščević, «Vis, l'antico porto», in *Archeologia subacquea in Croazia. Studi e ricerche*, ed. I. Radić Rossi, Venezia, 2006, p. 74-75, Tav. II, n. 18 e J. Mesić, «L'esplorazione archeologica a scopo protettivo della grotta di Vodeni Rat», in *Archeologia subacquea in Croazia. Studi e ricerche*, ed. I. Radić Rossi, Venezia, 2006, p. 96 e tav. 10.c.

<sup>59</sup> Emphasizing the presence of imports of globular amphorae in Apulia and in the Abruzzo see (R. Auriemma, E. Quiri, «La circolazione delle anfore», p. 42), and for Ancona (A. Toniolo, «Anfore dall'area lagunare», p. 101), as a possible places involved in an Adriatic sea network.

<sup>60</sup> See for instance M. McCormick's hypothesis, *Origins of the European Economy. Communications and Commerce, A.D. 300-900*, Cambridge, 2001, p. 537-547, about a "regional structure of shipping routes".