

ACT-FIELD SCHOOL PROJECT REPORTS AND MEMOIRS,
SPECIAL VOLUME



ISMEO
ASSOCIAZIONE INTERNAZIONALE DI STUDI
SUL MEDITERRANEO E L'ORIENTE

BUDDHIST ARCHITECTURE IN THE SWAT VALLEY, PAKISTAN

Stupas, Viharas, a Dwelling Unit

DOMENICO FACCENNA
PIERO SPAGNESI

WITH THE COLLABORATION OF
LUCA M. OLIVIERI

FOREWORD BY
MARCO MANCINI AND ADRIANO ROSSI



PAKISTAN-ITALIAN DEBT SWAP PROGRAM

ITALIAN ARCHAEOLOGICAL MISSION IN PAKISTAN
DIRECTORATE OF ARCHAEOLOGY AND MUSEUMS, KP PROVINCE

This Volume is published thanks to the generous support of ISMEO and Università di Bologna
“Alma mater Studiorum”, Dipartimento di Beni Culturali,
Printing costs were generously supported by a private grant.

Layout and graphic by BraDypUS



The Volume is realized in collaboration with the Università di Roma “La Sapienza”
Dipartimento di Storia, Disegno e Restauro dell’Architettura.
Editing by Elisabetta Valento and Erika Vecchietti.

Cover: the Stupa of Amluk-dara (February 2012).
(Photo by Luca M. Olivieri)

ACT-FIELD SCHOOL PROJECT REPORTS AND MEMOIRS

A SERIES EDITED BY
LUCA M. OLIVIERI
and M. NASIM KHAN (from September 2013)

PUBLICATION PLAN
(to date)

Volume I
(2013)

CONSTRUCTION ACTIVITIES IN SWAT DISTRICT (2011-2013)
KHYBER-PAKTHUNKHWA – PAKISTAN

THE NEW SWAT ARCHAEOLOGICAL MUSEUM
ARCHITECTURAL STUDY AND MASTERPLAN

Ivano Marati and Candida Vassallo

Volume II
(2014)

EXCAVATIONS AND CONSERVATION ACTIVITIES
IN SWAT DISTRICT (2011-2013)
KHYBER-PAKTHUNKHWA – PAKISTAN. 1

THE LAST PHASES OF THE URBAN SITE OF
BIR-KOT-GHWANDAI (BARIKOT)

THE BUDDHIST SITES OF
GUMBAT AND AMLUK-DARA (BARIKOT)

Luca M. Olivieri and others

Volume III
(in preparation)

EXCAVATIONS AND CONSERVATION ACTIVITIES
IN SWAT DISTRICT (2011-2013)
KHYBER-PAKTHUNKHWA – PAKISTAN. 2

EXCAVATIONS AT THE PROTOHISTORIC GRAVEYARDS OF
GOGDARA AND UDEGRAM

Massimo Vidale and others

RESTORATION AND CONSERVATIONS ACTIVITIES
AT SAIDU SHARIF I AND JAHANABAD

Edited by Luca M. Olivieri

Special Volume
(2014)

BUDDHIST ARCHITECTURE IN THE SWAT VALLEY, PAKISTAN.
STUPAS, VIHARAS, A DWELLING UNIT

Domenico Faccenna and Piero Spagnesi



ARCHAEOLOGY COMMUNITY TOURISM - FIELD SCHOOL (ACT)

ARCHAEOLOGY COMMUNITY TOURISM -FIELD SCHOOL (ACT)

A PROJECT BY
PAKISTAN-ITALIAN DEBT SWAP AGREEMENT (PIDSA)

IMPLEMENTED BY
ITALIAN ARCHAEOLOGICAL MISSION IN PAKISTAN

DIRECTORATE OF ARCHAEOLOGY AND MUSEUMS, KHYBER-PAKHTUNKHWA PROVINCE

WITH THE COLLABORATION OF
ISTITUTO SINDACALE PER LA COOPERAZIONE ALLO SVILUPPO (ISCOS-CISL)

UNDER THE VIGILANCE OF
DEPARTMENT OF ARCHAEOLOGY AND MUSEUMS
MINISTRY OF INFORMATION, BROADCASTING AND NATIONAL HERITAGE, GOVERNMENT OF PAKISTAN

TECHNICAL SUPPORT BY
PIDSA TECHNICAL SUPPORT UNIT - ISLAMABAD

FUNDED BY
MINISTERO PER GLI AFFARI ESTERI (MAE)
DIREZIONE GENERALE PER LA COOPERAZIONE ITALIANA ALLO SVILUPPO (DGCS, UFFICIO V)
UNITÀ TECNICA LOCALE (UTL) PAKISTAN, COOPERAZIONE ITALIANA ALLO SVILUPPO
(ITALIAN DEVELOPMENT COOPERATION - LOCAL TECHNICAL UNIT, PAKISTAN)
EMBASSY OF THE ITALIAN REPUBLIC IN PAKISTAN, ISLAMABAD

SUPPORTING INSTITUTIONS

MINISTERO PER GLI AFFARI ESTERI (MAE), DIREZIONE GENERALE PER LA PROMOZIONE DEL SISTEMA PAESE (UFFICIO VI)

ISTITUTO SUPERIORE PER LA CONSERVAZIONE E IL RESTAURO (ISCR), MINISTERO PER I BENI E LE ATTIVITÀ CULTURALI (MiBAC)

MINISTERO PER I BENI E LE ATTIVITÀ CULTURALI (MiBAC), DIREZIONE GENERALE PER IL PAESAGGIO, LE BELLE ARTI, L'ARTE E L'ARCHITETTURA CONTEMPORANEE

MINISTERO PER I BENI E LE ATTIVITÀ CULTURALI (MiBAC*), DIREZIONE REGIONALE PER I BENI CULTURALI E PAESAGGISTICI DEL FRIULI-VENEZIA GIULIA

UNIVERSITY OF ENGINEERING AND TECHNOLOGY, PESHAWAR

QUAID-I AZAM UNIVERSITY, TAXILA INSTITUTE OF ASIAN CIVILIZATION, ISLAMABAD

HAZARA UNIVERSITY, DEPARTMENT OF ARCHAEOLOGY, SCHOOL OF CULTURAL HERITAGE AND CREATIVE TECHNOLOGIES

HAZARA UNIVERSITY, DEPARTMENT OF CONSERVATION STUDIES

UNIVERSITÀ "FEDERICO II" DI NAPOLI, FACOLTÀ DI ARCHITETTURA, DIPARTIMENTO DI TECNICA DELLE COSTRUZIONI

UNIVERSITÀ DI BOLOGNA "ALMA MATER STUDIORUM", DIPARTIMENTO DEI BENI CULTURALI

UNIVERSITÀ DEL SALENTO, CENTRO DI DATAZIONE E DIAGNOSTICA (CEDAD)

UNIVERSITÀ DI FIRENZE, DIPARTIMENTO DI GESTIONE DEI SISTEMI AGRARI, ALIMENTARI E FORESTALI

UNIVERSITÀ DI PADOVA, DIPARTIMENTO DI BENI CULTURALI: ARCHEOLOGIA, STORIA DELL'ARTE, DEL CINEMA E DELLA MUSICA

UNIVERSITÀ DI PERUGIA, DIPARTIMENTO DI SCIENZE UMANE E DELLA FORMAZIONE

UNIVERSITÀ DI FIRENZE, FACOLTÀ DI ARCHITETTURA, DIPARTIMENTO DI COSTRUZIONI E RESTAURO

UNIVERSITY OF PENNSYLVANIA, DEPARTMENT OF ART HISTORY'S WILLIAMS FUND

DREXEL UNIVERSITY, PHILADELPHIA, ART AND ART HISTORY DEPARTMENT

EMBASSY OF THE ISLAMIC REPUBLIC OF PAKISTAN IN ITALY, ROME

GENERAL CONSULATE OF THE ISLAMIC REPUBLIC OF PAKISTAN, NEW YORK

CIVIL MILITARY LOGISTIC CENTER (CMLC), 19TH DIVISION, PAKISTAN ARMY, MINGORA

MANAGEMENT AND TECHNICAL STAFF

LUCA M. OLIVIERI, CO-SCIENTIFIC DIRECTOR, PROJECT
MANAGER (ISIAO AND UNIVERSITY OF BOLOGNA)

FAZAL DAD KAKAR, CO-SCIENTIFIC DIRECTOR
(DOAM, GOVT. OF PAKISTAN; UNTIL APRIL 2011)

SALEH MOHAMMAD (LATE), CO-SCIENTIFIC DIRECTOR
(DOAM KP; UNTIL JULY 2011)

NIDAULLAH SERAI, CO-SCIENTIFIC DIRECTOR (DOAM
KP; UNTIL JANUARY 2012; APRIL-AUGUST 2013)

SHAH NAZAR KHAN, CO-SCIENTIFIC DIRECTOR
(DOAM KP; UNTIL APRIL 2013)

MOHAMMAD NASIM KHAN, CO-SCIENTIFIC DIRECTOR
(DOAM KP, CURRENT)

ARSHAD KHAN, HONORARY PROJECT ADVISOR

FERYAL ALI-GOHAR, PROJECT CONSULTANT

IRMA GJINAJ, FINANCIAL MANAGER (ISCOS; UNTIL
SEPTEMBER 2011)

MARIO BARBERINI, FINANCIAL MANAGER (ISCOS)

SHEHRYAR MANNAN RANA, ADMINISTRATOR

M. HAFEEZ (DOAM, GOVT. OF PAKISTAN)

IVANO MARATI, ARCHITECT

CANDIDA M. VASSALLO, ARCHITECT

ZAREEF KHAN, SITE ENGINEER

ROBERTO DENTICI, TECHNICAL ADVISOR (MARCH-JUNE
2012)

SHER ALI KHAN, SITE ASSISTANT

FAIZ-UR-RAHMAN, DOAM KP FOCAL PERSON,
CURATOR SWAT MUSEUM

AMANULLAH AFRIDI, DOAM KP REPRESENTATIVE,
ASSISTANT CURATOR SWAT MUSEUM

MUNIR, DOAM KP, TECHNICAL RESPONSIBLE SWAT
MUSEUM

BALQEES BEGUM DURRANI, DOAM KP
REPRESENTATIVE

NAWAZ-UD-DIN, DOAM KP REPRESENTATIVE

SYED M. NIAZ ALI SHAH, DOAM KP
REPRESENTATIVE

SAEED AKBAR, TOURIST CONSULTANT

MASSIMO VIDALE, CHIEF TRAINER (UNIVERSITY OF
PADOVA)

MICHELE CUPITÒ, TRAINER (UNIVERSITY OF PADOVA)

ROBERTO MICHELI, TRAINER, (MiBAC*)

FRANCESCO MARTORE, RESTORER (ISIAO)

FABIO COLOMBO, RESTORER (ISIAO)

GIUSEPPE MORGANTI, CONSULTANT RESTORER (MiBAC)

ROBERTO SABELLI, CONSULTANT RESTORER
(UNIVERSITY OF FLORENCE)

FRANCESCO GENCHI, TRAINER (UNIVERSITY OF
BOLOGNA)

EDOARDO LOLIVA, PHOTOGRAPHER (ISCR)

M. AURANGZAIB KHAN, PHOTOGRAPHER

ILARIA SCERRATO (UNIVERSITY OF ROME 1)

SHAFIQ AHMAD, PROJECT ASSISTANT

AKHTAR MANIR, FIELD OFFICER

ALI KHAN, DRIVER

FAZAL MABUD, DRIVER

HAMID SHEHZAD, DRIVER

AZIZ-UR-RAHMAN, GUESTHOUSE MANAGER

UBAID KHAN, ENGLISH TEACHER

MURAD, ARTIST

Table of Contents

Foreword	xv
Marco Mancini and Adriano Rossi	
The legacy of Domenico Faccenna. A note	xvii
Luca Maria Olivieri	
Graphic Symbols and Terminology	xxi
Introduction	1
<i>A. STUPAS</i>	7
A1. Stupa of Gharasa (Dangram)	9
The Site	9
Bibliography and Documentation	9
The Stupa	10
<i>1st Storey, Quadrangular in Plan</i>	11
<i>2nd Storey, Circular in Plan</i>	11
<i>3rd Storey, Circular in Plan</i>	12
<i>4th Storey, Circular in Plan (Drum) and 5th Storey, Raised Dome with Internal Structures</i>	12
<i>Reconstruction</i>	13
A2. Stupa of Jurjurai	27
The Site	27
Bibliography and Documentation	27
The Stupa	28
<i>1st Storey, Quadrangular in Plan</i>	29
<i>2nd Storey, Circular in Plan</i>	29
<i>3rd Storey, Circular in Plan (Drum)</i>	30
<i>4th Storey, Raised Dome</i>	30

<i>Chattravali Disc</i>	30
<i>Reconstruction</i>	31
A3. Stupa of Loebanr	57
The Site	57
Bibliography and Documentation	58
The Stupa	58
<i>Double Platform; Stairways</i>	59
<i>1st Storey, Quadrangular in Plan; Stairway</i>	59
<i>Cell</i>	60
<i>2nd Storey, Circular in Plan; Stairway</i>	60
<i>3rd Storey, Circular in Plan (Drum); 4th Storey, Raised Dome</i>	61
<i>Internal Structure</i>	61
<i>Reconstruction</i>	62
A4. The Stupas of Arapkhanchina (Shararai)	87
The Site	87
Bibliography and Documentation	87
The Stupas	89
Stupa I	89
Stupa II	89
<i>1st Storey, Quadrangular in Plan</i>	89
<i>2nd Storey, Circular in Plan</i>	90
<i>3rd Storey, Circular in Plan (Drum)</i>	90
<i>4th Storey, Raised Dome</i>	90
<i>Chattravali Disc</i>	90
Stupa III	91
<i>1st Storey, Quadrangular in Plan</i>	91
<i>2nd Storey, Circular in Plan</i>	91
Stupa V	91
<i>1st Storey, Quadrangular in Plan</i>	91
<i>2nd Storey, Circular in Plan</i>	92
Stupa VI	92
General Remarks	93
A5. The Great Stupa (GSt) of Butkara I	135
The Site	135
A6. Stupa of Saidu Sharif I	137
The Site	137
A7. Stupa of Shnaisha	139
The Site	139
A8. Stupa of Shankardar	143
The Site	143

Bibliography and Documentation	143
Identification	147
The Stupa	148
<i>1st Storey, Quadrangular in Plan and 2nd Storey, Circular in Plan</i>	148
<i>3rd Storey, Circular in Plan (Drum)</i>	148
<i>4th and 5th Storeys (Composite Dome)</i>	149
<i>4th Storey, Circular in Plan, Transition Element</i>	149
<i>5th Storey, Raised Dome</i>	150
A9. Stupa of Amluk Dara	171
The Site	171
Bibliography and Documentation	172
The Stupa	175
<i>1st Storey, Quadrangular in Plan</i>	175
<i>2nd Storey, Circular in Plan</i>	177
<i>3rd Storey, Circular in Plan (Drum)</i>	177
<i>4th and 5th Storeys (Composite Dome)</i>	178
<i>4th Storey, Circular in Plan, Transition Element</i>	178
<i>5th Storey, Raised Dome</i>	178
<i>Chattravali Elements</i>	179
A10. The Stupas of Abbasahebchina (Najigram)	223
The Site	223
Bibliography and Documentation	224
The Central Complex	226
Stupa A	228
<i>1st Storey, Quadrangular in Plan</i>	228
<i>2nd Storey, Circular in Plan</i>	230
<i>3rd Storey, Circular in Plan (Drum)</i>	230
<i>4th and 5th Storeys (Composite Dome)</i>	231
<i>4th Storey, Circular in Plan, Transition Element</i>	231
<i>5th Storey, Raised Dome</i>	231
<i>The Stairway</i>	231
Stupa B	232
<i>1st Storey, Quadrangular in Plan</i>	232
<i>2nd Storey, Circular in Plan</i>	232
<i>3rd Storey, Circular in Plan (Drum)</i>	233
<i>4th and 5th Storey (Composite Dome)</i>	233
<i>4th Storey, Circular in Plan, Transition Element</i>	233
<i>5th Storey, Raised Dome</i>	233
<i>Relic Box</i>	233
Stupa C	234

<i>1st Storey, Quadrangular in Plan</i>	234
<i>2nd Storey, Circular in Plan and 3rd Storey, Circular in Plan (Drum)</i>	234
<i>4th and 5th Storeys (Composite Dome)</i>	235
<i>4th Storey, Circular in Plan, Transition Element</i>	235
<i>5th Storey, Raised Dome</i>	235
A11. Stupa of Tokar Dara (Najigram)	331
The Site	331
Bibliography and Documentation	332
The Stupa	334
<i>1st Storey, Quadrangular in Plan</i>	334
<i>2nd Storey, Circular in Plan</i>	335
<i>3rd Storey, Circular in Plan</i>	336
<i>4th Storey, Circular in Plan (Drum)</i>	336
<i>5th Storey, Dome</i>	336
<i>Chattravali Elements</i>	337
A12. The Stupas of Barikot	377
The Site	377
Bibliography and Documentation	377
The Stupas	379
Stupa A	379
Stupa B	380
A13. Stupa of Top Dara (Haibatgram, Thana)	387
The Site	387
Bibliography and Documentation	388
The Stupa	390
<i>Platform</i>	391
<i>1st Storey, Quadrangular in Plan</i>	391
<i>2nd Storey, Circular in Plan</i>	392
<i>3rd Storey, Circular in Plan (Drum)</i>	392
<i>4th and 5th Storey (Composite Dome)</i>	392
<i>4th Storey, Circular in Plan, Transition Element</i>	392
<i>5th Storey, Raised Dome</i>	393
<i>Plaster</i>	393
<i>Chattravali Disc</i>	393
A14. Stupa of Gumbatuna	419
The Site	419
Bibliography and Documentation	419
The Stupa	422
<i>1st Storey, Quadrangular in Plan</i>	422
<i>2nd Storey, Circular in Plan</i>	423

3 rd Storey, Circular in Plan (Drum)	423
4 th and 5 th Storeys (Composite Dome)	424
4 th Storey, Circular in Plan, Transition Element	424
5 th Storey, Raised Dome	424
B. VIHARAS	443
B1. Vihara of Abbasahebchina	445
B1.1. Vihara F	445
The Site	445
Bibliography and Documentation	445
The Vihara	446
<i>Supporting Structures</i>	446
<i>Podium (A)</i>	446
<i>Aedicula (B)</i>	446
<i>Lower Roof Covering (C)</i>	447
<i>Intermediate Body (D)</i>	447
<i>Upper Roof Covering (E)</i>	448
<i>Entrance Plan (F)</i>	448
<i>Reconstruction</i>	448
B1.2. Small Vihara	449
B2. Vihara of Gumbat	465
The Site	465
Bibliography and Documentation	465
The Vihara	467
<i>Cell</i>	467
<i>Corridor around Perimeter</i>	468
<i>External Mouldings of the Various Bodies of the Construction</i>	468
<i>Lighting</i>	468
<i>Stairway</i>	469
<i>Construction Technique</i>	469
<i>Conservation and Restoration</i>	469
The Sacred Area	470
B3. Vihara of Kanjar Kote	503
The Site	503
Bibliography and Documentation	503
The Area and the Viharas	505
B3.1. Double Vihara	506
B3.2. Circular Vihara	507
B4. Vihara of Gumbatuna	521
The Site	521
Bibliography and Documentation	521

The Circular Vihara	522
Comparisons	523
<i>C. DWELLING UNIT</i>	529
C1. Dwelling Unit of Abbasahebchina	531
The Site	531
Bibliography and Documentation	531
The Dwelling Unit	531
Conclusions	537
A. Stupa	537
<i>General features</i>	537
Zone of Jambil-Saidu	537
A1. Gharasa	537
A2. Jurjurai	537
A3. Loebanr	538
A4. Arapkhanchina	538
A5. Great Stupa (GSt.) of Butkara I	539
A6. Saidu Sharif I	539
A7. Shnaisha	540
Zone of Barikot	540
A8. Shankardar	540
A9. Amluk Dara	540
A10. Abbasahebchina	541
A11. Tokar Dara	542
A12. Barikot	543
Zone of Thana	543
A13. Top Dara	543
Zone of Gumbatuna	543
A14. Gumbatuna	543
Typological and Chronological Observations	544
<i>Typology</i>	544
<i>Zones of Jambil-Saidu and Barikot-Thana-Gumbatuna Compared</i>	545
Chronology	547
B. Viharas	547
Zone of Barikot	547
B1.1. Vihara F of Abbasahebchina	547
B1.2. Small vihara, rectangular in plan.	547
B2. Vihara of Gumbat	547
B3.1. Double vihara of Kanjar Kote	548
B3.2. Vihara, circular in plan.	548

Zone of Gumbatuna	548
<i>B4. Vihara of Gumbatuna</i>	548
Some Overall Considerations	548
C. Dwelling Unit	549
Zone of Barikot	549
<i>C1. Dwelling unit of Abbasahebchina</i>	549
Buddhist Architecture in the Swat Valley: several final notes	549
References	555

Foreword

Five years ago Domenico Faccenna, honorary member of the Italian Institute for Africa and the Orient (IsIAO), who dedicated the largest part of his scientific activity to many aspects of the past culture of the valley of Swat, passed away in Rome. He could not see the publication of the present book, the last volume containing reports of the field works in the valley of Swat which he had programmed and realized, after the publication of the masterly reports of the excavations at Butkara I, Saidu Sharif I and Panr I.

The volume which we have the pleasure to introduce, dedicated to the study and survey of the non-excavated Buddhist monuments of Swat, with which Faccenna associated Piero Cimbolli Spagnesi, sees now the light thanks to the converging efforts of his disciples, coordinated by Pierfrancesco Callieri. In this way a life cycle, which brought a substantial contribution in the progress of knowledge of the ancient civilizations in this area of Pakistan, comes to an end.

The publication could be reached only much later than it was hoped. In 2008 the text file was ready, but not yet edited, while the many illustrations were to be selected and prepared for publication by the editorial staff of the IsIAO, the Italian public Institute from which the Italian Archaeological Mission in Pakistan depended.

After 2011, the dramatic end of the Institute – resulting in no benefit for the Italian public budget, and a debacle for the international prestige and cultural role of Italy – provoked a halt to the publishing process of the volume. It was only thanks to the support of the Dipartimento di Beni Culturali of the University of Bologna, of the Associazione ISMEO created in order to save the rich heritage of the IsIAO, and of the ACT Project, that the last steps could be carried out until its publication. The new ISMEO, that claims a right to the scientific and cultural legacy of that prestigious Institute, sets itself in full continuity with the tradition of the late IsIAO also by the publication of this volume, by which a new series continuing the series Reports and Memoirs is inaugurated. Moreover, by this publication is strongly reaffirmed ISMEO firm determination to continue researches and activities in that rich depository of world treasures which is Pakistan.

The role of ACT and of his Scientific Director, Luca Maria Olivieri, has been seminal for the continuation of the Italian activities in the valley of Swat, and we wish to take this opportunity to present a warm sentiment of gratitude to Dr Olivieri, on behalf of all the scientific community working in the Gandharan region and particularly of the Associazione ISMEO. In the frame of the ACT project, indeed, many activities which the IsIAO Italian Archaeological Mission had not the possibility to carry out were finally reached: among these we wish to remind the conservation of the Saidu Sharif I Buddhist Sanctuary and the renovation of the Swat Museum, along with the continuation of the excavations at Bir-kot-ghwandai.

The publication of the volume is a token of gratitude which all those who have contributed pay to Domenico Faccenna, and present to his family, which has always supported the continuation of his work.

Our gratitude goes also to the Italian Ministry of Foreign Affairs, who has not ceased to grant its support to the Italian Archaeological Mission, particularly now that its activities are being carried out in the frame of the Associazione ISMEO.

We wish, last but not least, to thank Piero Cimbolli Spagnesi, professor at the “La Sapienza” University of Rome for having contributed to this volume.

Rome, 15th October 2013

Prof. MARCO MANCINI, President of ISMEO

Prof. ADRIANO V. ROSSI, Scientific Director of ISMEO

The legacy of Domenico Faccenna. A note

The background

The Italian Archaeological Mission in Pakistan (IAM), founded by Giuseppe Tucci as a research unit of the Centre for Excavation and Archaeological Research in Asia of the Institute for the Far and Middle East, IsMEO, began in 1956. Created by Tucci, the mission was actually a successful enterprise of Domenico Faccenna, a giant in the field of South Asian archaeology.

Under his direction, the mission obtained important results right from the outset, with the successful digs conducted by himself in the Buddhist sanctuaries of Butkara I, Panr I and Saidu Sharif I. Soon after, the mission opened up other important excavations, uncovering Protohistoric graveyards, Early- and Late-Historic settlements, and Islamic monuments. Participants in the fieldwork were, among others, Giorgio Gullini, Giorgio Stacul, Massimo Taddei and Umberto Scerrato. In 1984 Pierfrancesco Callieri began exploring Bazira (Barikot), a fortified city dating to Indo-Greek times; in 1986 Umberto Scerrato discovered the third oldest mosque in Pakistan, founded by a general of Mahmud of Ghazni, in Udegram; in the year 2000 Massimo Vidale, together with the present writer, began compiling an Archaeological Map of the Swat Valley which includes an extremely rich panorama of rock art.

Archaeology and financial reconversion: A project of cooperation

As early as 2007 the Mission conceived the idea of a comprehensive project focusing on archaeology and the sustainable enhancement of the territory, as well as on job creation. The Mission's standard model of operation was planned to be replicated on a larger scale, and to serve as a model for future enterprises, in Swat and elsewhere.

An important lesson from the Mission's continuous work in the area, even during most difficult times, was that wherever the local communities were engaged in the

Mission's work, they managed to defend and preserve their local archaeological sites. This model of sustainable protection, initially conceived by Domenico Faccenna, proved to be successful even under the most challenging circumstances.

With this in mind, the Mission, together with its counterpart at the time, the Department of Archaeology and Museums (DOAM), (Federal) Government of Pakistan, drafted a new project, named "Archaeology-Community-Tourism Field School" (ACT).

Funding for ACT was obtained through the financial instrument provided by the "Pakistan-Italian Debt Swap Agreement" (PIDSA) supported by the Italian Cooperazione allo Sviluppo.

The Cooperazione allo Sviluppo of the Italian Ministry of Foreign Affairs Esteri considers culture as a direct and indirect tool for economic development. In this respect Italy is in the vanguard, with some very successful integrated "debt-swap" projects, first in Yemen and Egypt, and now in Pakistan. The example of the Swat Valley is particularly emblematic, since tourism (with archaeology playing a very prominent role) has traditionally been its second most important source of income. The objective of the ACT project is precisely to propose a model of intervention aimed at contributing to economic revival through the development of archaeological tourism involving local communities.

New data on the Buddhist sacred areas

After the seminal work carried out by Domenico Faccenna and thoroughly illustrated in this Volume, new research were launched in the area around Barikot. This area contains many Buddhist sanctuaries, whose remains, even if heavily looted, still dominate a unique archaeological landscape. Amongst these research we should mention particularly the excavations at Gumbat and Amluk-dara, under the ACT Project. The great sanctuary of Gumbat, the only double-domed Gandharan monument in existence, was in danger of collapsing. The project, besides offering guidelines for preliminary restoration (with a "light" technique consisting of partial dry-wall masonry reconstruction) secured the area and allowed a partial excavation of the stupa terrace to be carried out. C₁₄ analysis has revealed that the double-domed sanctuary was erected no later than the 2nd century CE, and that the sacred area, dominated by three surrounding large sanctuaries, remained in use until relatively late times. During these late phases, the great stupa of Amluk-dara, the major monument of the Swat Valley, underwent a series of reconstructions contemporary with the great stupas of the Kabul valley, marked, like the one at Amluk-dara, by huge frontal niches.

After the excavations, both sites revealed new data especially concerning their architecture, general dimensions, moulding detail etc. Of course, all these details

Luca Maria Olivieri
The legacy of Domenico Faccenna. A note

were not available at the time when Faccenna studied these two monuments (see this Volume *infra*). New data and integrations are available for the reader in the second Report published in the same series of this important Volume.

To Domenico, *con riconoscenza*,

Luca Maria Olivieri
Saidu Sharif 25th, September 2013

Graphic Symbols and Terminology



- 1. line of cross section
- 2. restitution of structure, existing though not visible
- 3. restitution of lost structure, certain
- 4. restitution of lost structure, probable



- 5. section of wall

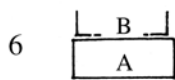

- 6. structure B abutting onto A (earlier); plan view

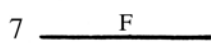

- 7. floor (F): beaten clay

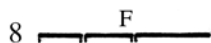

- 8. floor (F): paved

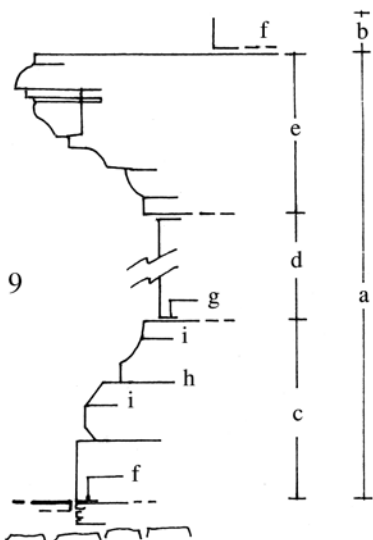

- 9. a: 1st storey. b: 2nd storey. c: base. d: wall. e: cornice.
f: dividing line between storeys or part of storeys
g: dividing line between part of storeys
h: moulding line
i: slab (as part of a moulding)
(plaster coating is not shown)

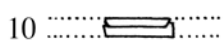

- 10. Mouldings: preserved portion (complete)

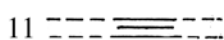

- 11. Mouldings: visible portion (incomplete; ref. no. 2)

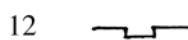

- 12. pilaster built as part of wall



- 13. data point



- 14. surface humus

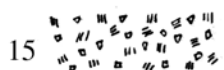

- 15. loose earth with gravel

STUPA AND VIHARA

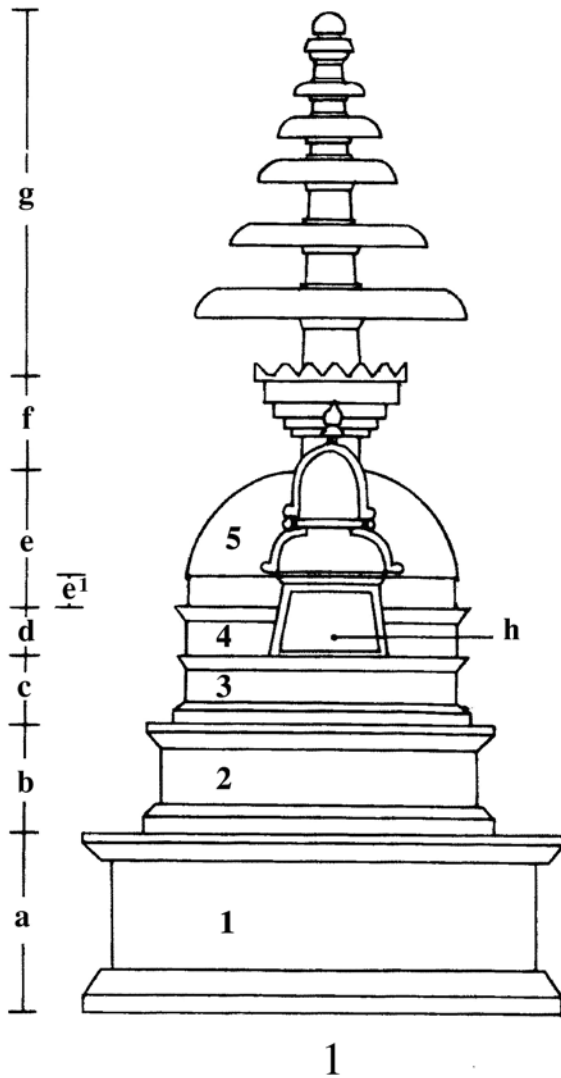

1 – Stupa: elevation

- a: 1st storey, quadrangular in plan
- b: 2nd storey, circular in plan
- c: 3rd storey, circular in plan
- d: 4th storey, circular in plan (= drum)
- e: 5th storey (= dome)
- e¹: raised part of the dome
- f: harmika
- g: pinnacle (= chattravali)
- h: false-niche

The numbering of the storeys varies according to the type of the stupa

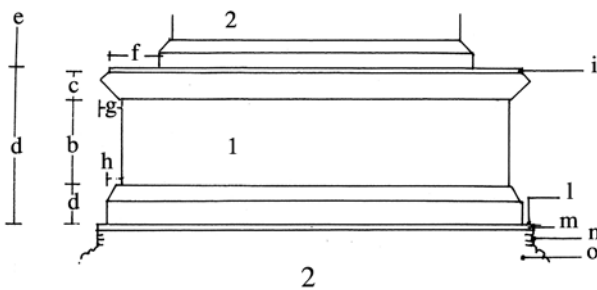

2 – Stupa: 1st storey

- b: body
- c: cornice
- d: 1st storey, quadrangular in plan
- e: 2nd storey, circular in plan
- f: setback (rebate)
- g: projection of the cornice
- h: projection of the base
- i: coping slab
- l: footing level
- m: projecting foundation
- n: levelling with facing of chips
- o: foundations

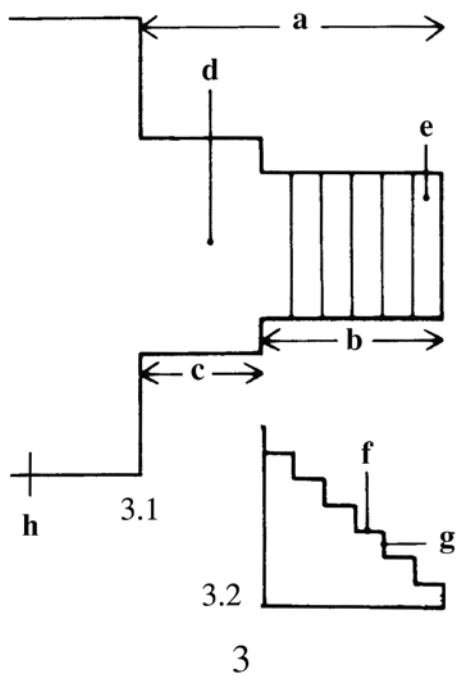

3 – Stairway

3.1: (plan)

3.2: (elevation)

a: stairway

b: flight of steps

c: projection

d: landing

e: step

f: tread

g: riser

h: body of the stupa

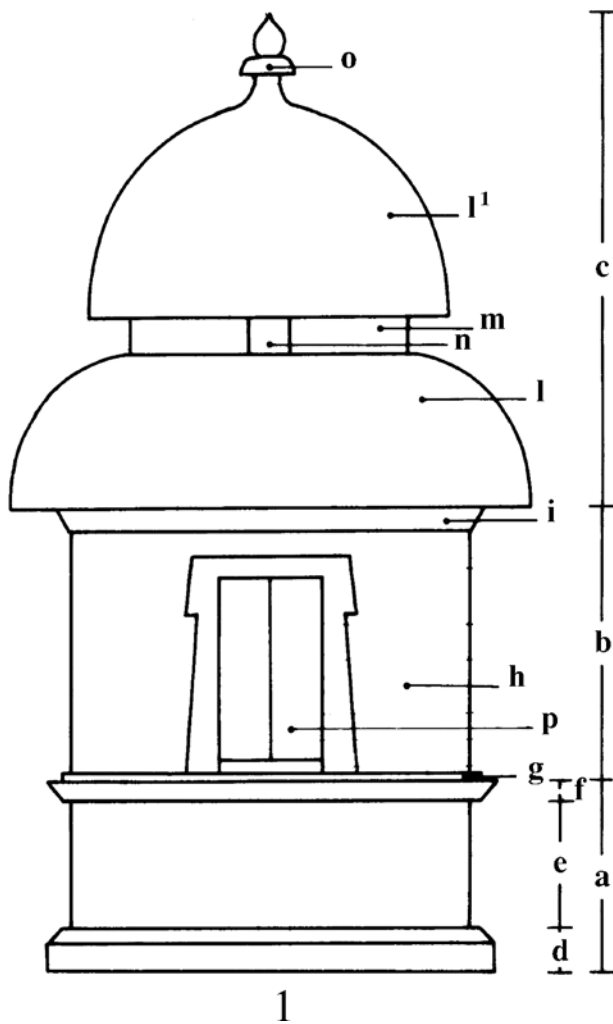

- 1 – Vihara with podium: elevation
- a: podium
 - b: body
 - c: double roof covering
 - d: base of podium
 - e: wall of podium
 - f: cornice of podium
 - g: coping slab of podium
 - h: wall facing of body
 - i: cornice of body
 - l: four-sided curved sloping lower roof
 - l1: upper roof covering (= dome)
 - m: intermediate cylindrical body
 - n: window of intermediate cylindrical body
 - o: finial
 - p: door

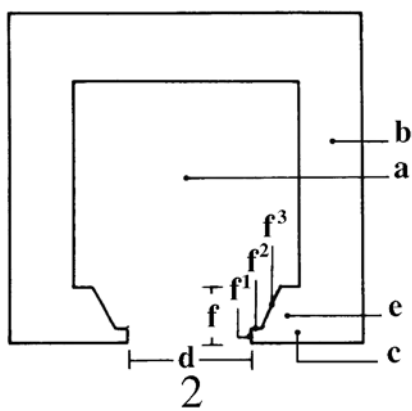

- 2 – Vihara: plan
- a: cell
 - b: wall
 - c: anta
 - d: door
 - e: jamb
 - f: inner side of jamb
 - f¹: reveal
 - f²: projection of the reveal
 - f³: splayed jamb

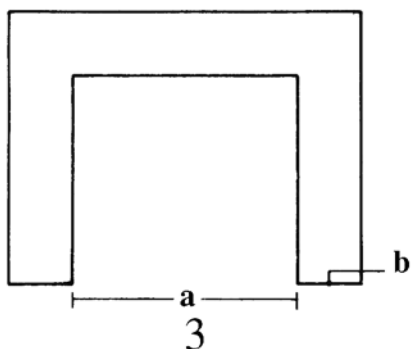

- 3 – Open vihara: plan
- a: opening (full width)
 - b: prodruing wall (without anta) to frame doorway

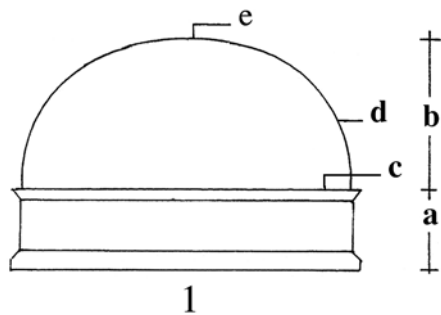

- 1 – *Semi-circular dome*
 a: drum
 b: dome (decorated: type)
 c: springing line
 d: haunch
 c-d: shoulder of the dome
 e: top

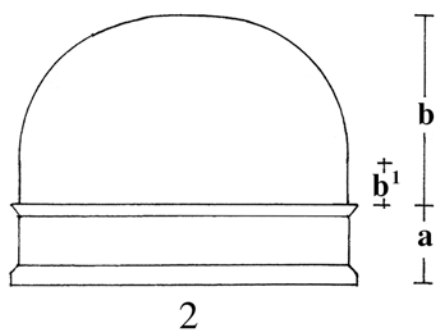

- 2 – *Raised dome*
 a: drum
 b: raised dome
 b1: raised part

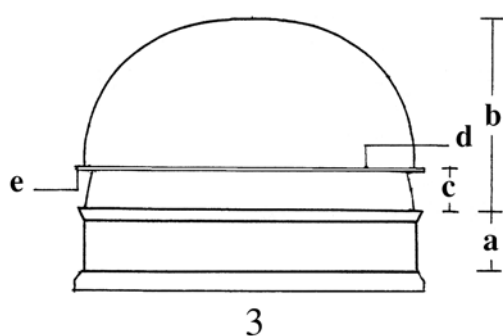

- 3 – *Composite dome*
 a: drum
 b: composite dome
 c: connecting element
 d: springing line
 e: projecting slabs

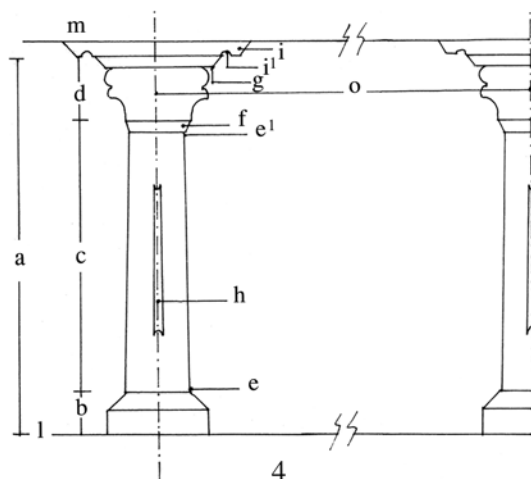

- 4 – *Body of monument with pilasters*
 a: pilaster
 b: base
 c: shaft
 d: capital
 e: lower scape
 e¹: upper scape
 f: collar
 g: abacus
 h: flute with upper and lower bevelled ends
 i: modillion
 i¹: hollow of the modillion
 l: base of the body
 m: cornice of the body
 n: axis
 o: inter-axis

BASE E AND CORNICE OF MONUMENT (shown without plastering, which would alter the profile)

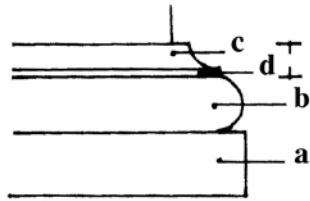

1.1

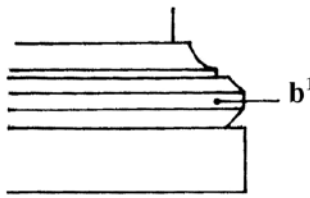

1.2

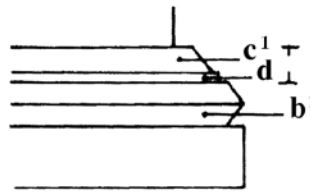

1.3

1

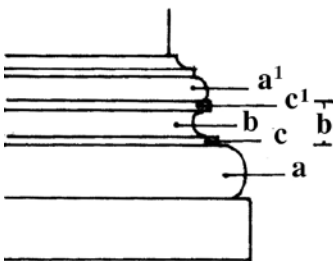

2.1

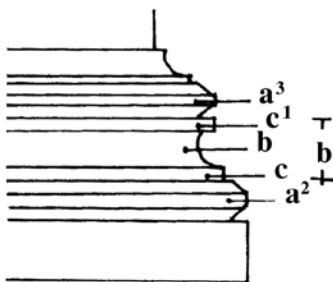

2.2

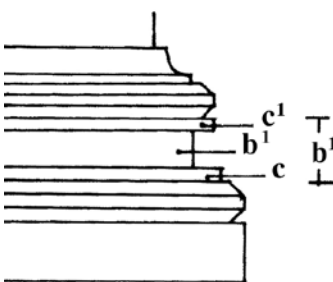

2.3

2

1 – Base of monument of torus type

- 1.1: with (smooth) torus
- 1.2: with three-sided bevelled torus
- 1.3: with carenated torus
- a: plinth
- b: (smooth) torus
- b¹: three-sided bevelled torus
- b²: carenated torus
- c: cavetto
- c¹: straight cavetto
- d: fillet

2 – Base of monument of scotia type

- 2.1: with (smooth) torus
- 2.2: with three-sided bevelled torus
- 2.3: with straight scotia
- a: lower (smooth) torus
- a¹: upper (smooth) torus]
- a²: three-sided bevelled lower torus
- a³: three-sided bevelled upper torus
- b: scotia
- b¹: straight scotia
- c: lower fillet
- c¹: upper fillet

Graphic Symbols and Terminology

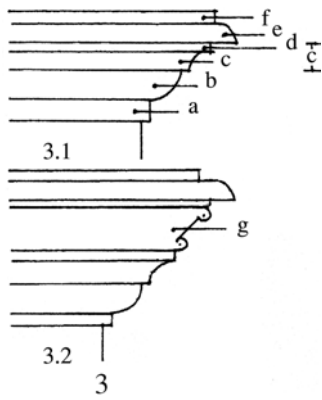

- 3 – *Cornice of monument*
- 3.1: with ovolo and cavetto
- 3.2: with brackets
- a: fillet
- b: ovolo
- c: cavetto
- d: fillet
- e: ovolo rovescio
- f: coping slab
- g: bracket

MOULDINGS

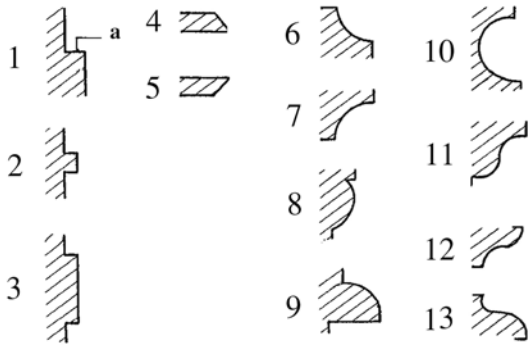

- 1 – rebate
- a: projection of the rebate
- 2 – projecting fillet
- 3 – projecting band
- 4 – sloping fillet (projecting lower edge)
- 5 – sloping fillet (projecting upper edge)
- 6 – cavetto
- 7 – reverse cavetto
- 8 – ovolo
- 9 – ovolo (upright)
- 10 – scotia
- 11 – cyma recta
- 12 – cyma reversa
- 13 – inverted cyma

BRACKET

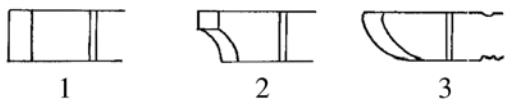

- 1 – parallelepiped type
- 2 – reverse cavetto type
- 3 – ovolo type

ARCH

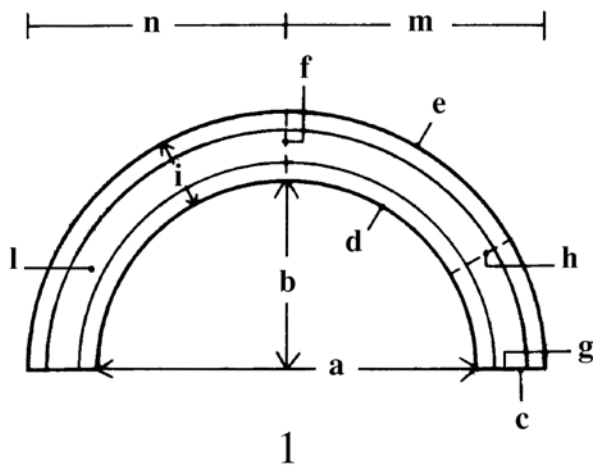

- 1 – Arch
- a: span
- b: rise
- c: impost on jambs
- d: intrados
- e: extrados
- f: crown
- g: springer
- h: haunch
- g-h: shoulder of arch
- i: thickness
- l: frame
- m: right haunch.
- n: left haunch

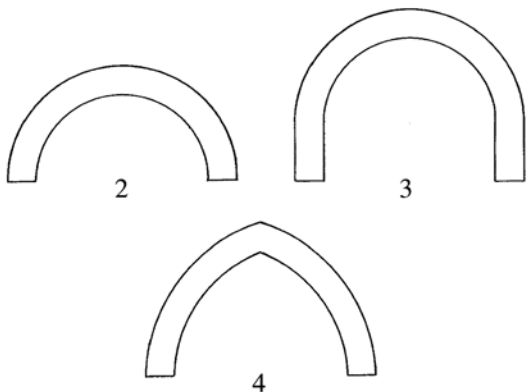

- 2 – round arch
- 3 – raised round arch
- 4 – pointed arch

Introduction

The excavation reports of the Buddhist sacred areas prepared by the Italian Archaeological Mission of IsMEO (then IsIAO) regarding the sacred areas of Butkara I, Panr I and Saidu Sharif I in the Swat Valley, describe the work carried out in each of them and the results thereof (Faccenna 1980-81, 1995a; Faccenna, Nabi Khan & Nadiem 1993). Together with the accurate description of the monuments discovered, they represent a firm base on which to build an adequate and relatively satisfactory investigation of sacred Buddhist Gandharan architecture (in Pakistan, Afghanistan and related cultural areas, Central Asia) through the various types that characterize it (stupas, viharas, columns, minor complementary structures) and the various complexes to which the latter belong (sacred areas, monasteries, groups of dwelling units for monks, water supply and defence systems). According to this working programme, the analysis was originally intended to touch upon numerous aspects: construction techniques, materials, measures, plasters, proportions, pictorial decorations and gilding. Above all it was intended to take in architecture as a whole, in its spaces, volumes and relative design themes. The study of the architecture was to be supported by that of other classes of materials: in particular, its various representations on reliefs, paintings and graffiti and above all reliquaries and models (made of stone, bronze and terracotta). A further valid contribution was also to be made by the excavations carried out by the Department of Archaeology and Museums of the Federal Government of Pakistan (Khan Ashraf 1993) and by the Department of Archaeology of the University of Peshawar (Dani 1965-66, 1968-69; Rahman 1993b).

Within the framework of this programme, our intention here is to present the documentation referring above all to one of these types of architecture: the large stupas situated in the Swat Valley and lying outside the excavation areas. They are indicated with a serial number marked with the letter A. For this reason a detailed examination was made of the stupas of Butkara I in the Jambil Valley (no. A5) and of Saidu Sharif I and Shnaisha in the Saidu Valley (nos. A6 and A7),

in any case referring to the relevant publications: in view of their importance, they have nevertheless been included in the overall numerical framework and briefly analysed in the Conclusions. It should in any case be emphasized – and this must always be borne in mind – that the analysis of individual architectural styles is strictly limited to the monument under examination and not extended to the relative sacred areas or other surrounding buildings, in any case accepting as known the overall references (with some specific exceptions) to what has already been excavated in other Swat areas and elsewhere or to what has been described also in some recent overall studies (Behrendt 2004; Spagnesi 2006).

The area involved lies between Mingora and Thana and has been subdivided into several zones (Fig. 1). From North to South, the monuments examined are as follows: in the Jambil-Saidu zone, in the Jambil Valley on the right bank of the river, at Gharasa (Dangram) (no. A1) and on the left, beginning from the most distant, at Jurjurai (no. A2), Loebanr (no. A3), Arapkhanchina (Shararai) (no. A4). These are followed, along the Swat River on the road from Mingora to Barikot, by the Stupa of Shankardar, considered as belonging to the zone of Barikot (no. A8). In the zone to the immediate East, between Barikot and the Karakar Pass, lie the stupas of Amluk Dara (no. A9), Abbasahebchina (n. A10), Tokar Dara (Najigram) (no. A11) and those of Barikot itself (no. A12). The series is concluded by the stupas in the Thana zone of Top Dara (Haibatgram, near Thana) (no. A13) and, on the right bank of the Swat River, of Gumbatuna in the zone of the same name (no. A14).

In a separate part, marked with the letter B, several viharas are examined: at Abbasahebchina (nos. B1.1, B1.2), Gumbat (no. B2), Kanjar Kote (nos. B3.1, B3.2), Gumbatuna (no. B4) and in one further part, marked with the letter C, there is an example of a monks' dwelling unit at Abbasahebchina (no. C1).

After the first wide-ranging preliminary archaeological reconnaissance of Swat in 1926 by Sir Aurel Stein (1930), followed in 1938 by another by Barger & Wright (1941) limited to a few zones, and after the systematic exploration of the whole valley in 1956 by Prof. Giuseppe Tucci (1958), carried out together with Dr. F. A. Khan, the then director of the Exploration Branch of the Federal Archaeological Department, and Francesca Bonardi, the study of the architecture of the monuments got under way at the same time as the excavation of the sacred area di Butkara I, although only the time left over from the latter work according to the circumstances was dedicated to it.

Drawings and surveys accumulated over a period of many years: by Vittorio Caroli (1956-1964; Abbasahebchina: stupa, vihara, dwelling unit; Amluk Dara; Loebanr), assisted by Abdul Ghafoor: the faithful, skilful and generous supervisor (1956-1962); Pietro Gui and Enzo Cimmino (1964-1965; Arapkhanchina; Loebanr; Shankardar; Tokar Dara; Amluk Dara; Gumbat; Abbasahebchina: stupas A, B, C

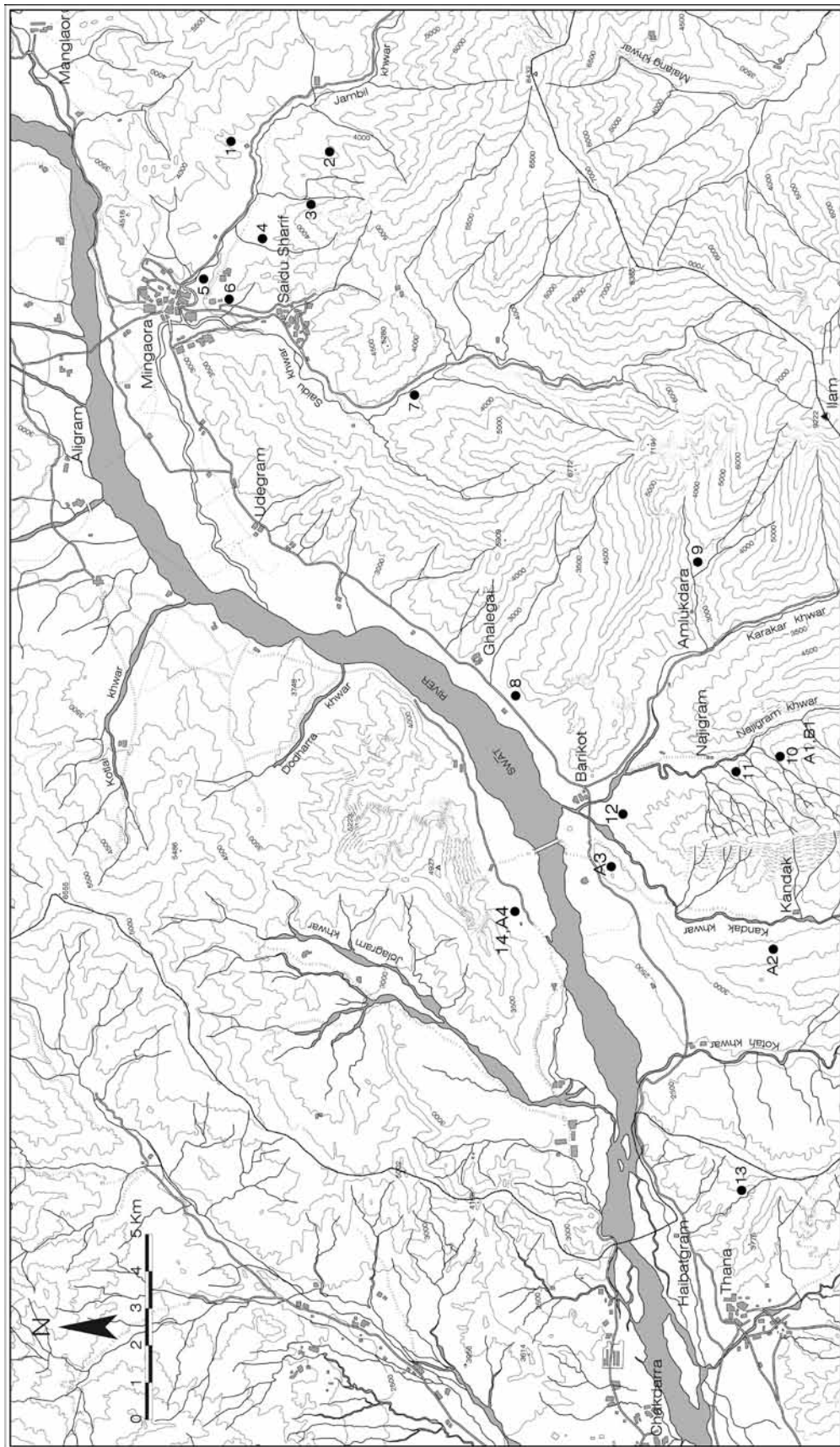

Fig. 1. General map of stupas, viharas, and dwelling units. (Drawing by S. D'Acchille).
Stupa. Zone of Jambil and Saidu: 1. Stupa of Gharasa (Dangram). 2. Stupa of Jururai. 3. Stupa of Loebanr. 4. Stupas of Arapkanchina (Shararai). 5. Great Stupa of Butkara I. **Saidu Valley:** 6. Main Stupa of Saidu Sharif I. 7. Main Stupa of Shnaisha. **Zone of Barikot:** 8. Stupa of Shankardar. 9. Stupa of Amluk Dara. 10. Stupas of Abbasabechna (Najigram). 11. Stupa of Tokar Dara. 12. Stupas of Barikot. **Zone of Thana:** 13. Stupa of Top Dara (Haibatgram, Thana). **Zone of Gumbatuna:** 14. Stupa of Gumbatuna.
Vihara. Zone of Barikot: A.1.1. Vihara F of Abbasabechna. A.1.2. Small vihara of Abbasabechna. A.2. Vihara of Gumbat. A.3.1. Vihara of Kanjar Kote. A.3.2. Double vihara of Kanjar Kote. A.3.3. Circular vihara of Kanjar Kote. **Zone of Gumbatuna:** A.4. Vihara of Gumbatuna. **Dwelling unit. Zone of Barikot:** B.1. Dwelling unit of Abbasabechna.

and vihara F; Kanjar Kote; Gumbatuna); Tullio Tamagnini (1966; Gumbatuna: stupa and vihara; Kanjar Kote); Luca Mariani (1968); Giuseppe Tilia (1980; Tokar Dara); Roberto Sabelli (1993; with his group made up of Anna Mannari, Maria Rita Galanti and Fabio Mosca), to whom the majority of drawing-based surveys contained in the present work are owed; Piero Spagnesi (2005; Tokar Dara); and to conclude with those of Francesco Martore, to whom several surveys are owed (1986-2003; Tokar Dara and Gumbatuna) and the complete reorganization and normalization of the graphs (2003-2004). At the same time, several members of the Mission carried out extensive explorations of the various locations ⁽¹⁾. Particular mention must be made of the work of Francesca Bonardi Tucci (1958-1962), Maurizio Taddei (1958-1961), Umberto Scerrato (1959), Luca Mariani (1968), Luca M. Olivieri (1992, 1993) and Mauro Nascari (1991, 1993), all of whom made detailed observations of the individual architectural forms. During the various survey campaigns Faccenna proceeded to write up his notes. In all of this mention must also be made of the contribution by friends and other visitors to the sites who kindly offered their photographs to the Mission – one of whom was Shoshin Kuwayama. We shall always be grateful to them.

Each description illustrates a single monument starting from the place where it stands, with the relative building history and, as a footnote, the passages quoted from the texts describing it. On the basis of what has survived, each architecture is then described in its various component parts, leading to its possible reconstruction in which several specific features are emphasized. Sketches and photographs must be considered an integral part of the work and should be examined in parallel with the text, also in order to avoid having to provide a list of useless and unclear measures.

Where not otherwise indicated, the negatives are preserved at the Museo Nazionale d'Arte Orientale "Giuseppe Tucci", Rome, in the Archive of the Centro Scavi of the former IsMEO-IsIAO Italian Archaeological Missions in Asia (CS).

The following are provided for each monument: a plan view and cross section of the real state (1:50), a sketched plan view and elevation showing the measures (in the elevation the measures are on the left, and the metric scale on the right; the measures were taken of the bare walls, neglecting any plaster) (1:100), an elevation profile of individual bodies with base and crowning mouldings and any other elements (especially pilasters), rendered according to their real conditions and in the reconstruction with and without plaster (1:10), a reconstructed plan and elevation (with plaster) (1:50) and an axonometric view (on a 1:100 base plane); these are concluded by plans and sections of any chattravali disks (1:2, 1:1).

The sketches have been reduced to different graphic scales, although always respecting their relative dimensions within homogeneous groups. The graphic

⁽¹⁾ For the history of the Mission, see Olivieri 2006.

rules applied are those already illustrated in Faccenna 1980-81: 19-20, pls. I-II; 1995a: 39, pls. I-V; Faccenna, Nabi Khan & Nadiem 1993: 31-36: pls. I-V, although adapted and with additions and modifications to suit the requirements of the present work. The orientation, accurate in the sketches, has been simplified in the text. Likewise, for the sake of convenience, the various bodies of the stupas are indicated in the sketches using serial numbers while they are accompanied by adjectives in the text. Several Sanskrit nouns in common usage – such as stupa and vihara – are not in italics. For the transcription of place names a simplified, widely accepted, transliteration using roman type and avoiding diacritic signs is used. Lexical definitions, the entry words, are those given in Faccenna & Filigenzi (2007: part 3).

The sketches depict the situation regarding each single monument as at 1993, the year they were made. This is a significant date that must always be borne in mind when assessing what has happened to each of the artifacts since then.

Each series of sketches is concluded with a reconstruction executed with the maximum caution. Each of them is the outcome of personal descriptions and notes, sketches and photographs taken at different times (starting from the earliest evidence), thus documenting also the process of *transformation* of the various types of architecture. The action of time, but above all the work of man – brought about, sometimes slowly, sometimes rapidly and in a starkly insulting way, their tragic decline and often their complete disappearance. Added to the various events marking their prolonged and continuous lives are all the difficulties inherent in a work of this kind, the results of which are presented here, performed on unexcavated monuments: for this reason we are only too aware of the inevitable likelihood of errors being committed.

A.

STUPAS

A1. Stupa of Gharasa (Dangram)

(Figs. 2-19)

The Site

Jambil-Saidu zone. Jambil Valley.

Position: Lat. 34°45'N; Long. 72°24'E; Survey of Pakistan Map, Sheet no. (hereafter named SPM) 43 B5.

On the road running from Mingora along the Jambil Valley, on the left bank of the river of the same name, beyond the village of Dangram, a path leads up to the terraces enclosed at the bottom of the sweep of Mt Gharasa, traversed and cut by seasonal watercourses. The whole area is dotted with ancient structures.

On the mountain slopes, on the S side of a plateau delimited by the sides of a spur leading off from it, lies the Stupa of Gharasa.

From here the terrain slopes down gently towards the W, sharply towards the S, where a seasonal watercourse runs at the bottom, while to the N the mountain slopes upwards and to the E the terrace continues to rise.

Bibliography and Documentation

Stein 1930: 46; in his exploration of the Jambil Valley mentions only the village.

Tucci 1958: 288, 316, n. 24; in all likelihood he identifies the village of Dangram with Dhānyapura, 'city of rice', (where Buddha converted the mother of King Uttarasena), mentioned in the *Vinaya*; in the same n. 24 he states that Dangram is 'extremely rich in archaeological remains'; he makes no mention of the stupa.

Faccenna 1964: 25.

Gui and Cimmino 1964-1965: reconnaissance and report.

Faccenna 1980-1981: 755, n. 2.

Olivieri 1991, 1993: photos and report.

Nascari 1992, 1993: photos and report.

Sabelli 1993: graphic survey.

Kuwayama 1993: photos.

Martore 2003: check of measures, corrections, updating of graphics and symbols.

Filigenzi 2014.

The Stupa

The stupa, rectangular in plan, has a stairway facing W. Very poor state of conservation, especially in recent years, owing to the removal of stone material for use in new building.

The S side of the 1st storey, facing the stream, has been conserved and is visible over practically its entire length and to a relatively high elevation; the other sides have been filled in; it is followed by short sections of the two circular bodies with part of the structure of the 2nd storey stairway. The shapeless core rises further above the 3rd storey up to a certain height.

It is built with large-size squared blocks with a carefully worked front face, the upper and lower faces with regular cuts, the lateral ones with less carefully executed cuts; they are regularized on the four faces, but above all on the sides, by superimposed rows of small slabs. This construction, in an excellent state of conservation, is visible on the S wall of the 1st storey and is aesthetically quite appealing. Parallelepiped shaped blocks of some considerable length are visible: 0.80 x 0.40 h., 1.05 x 0.47 h., 1.35 x 0.35 h. They are made of fine-grained gneiss, while the small slabs are made of dark phyllite. They are larger in the lower rows, and decrease in size towards the upper part of the wall. They are arranged in regular rows, superimposed on each other and spaced as closely together as possible. The resulting empty spaces on the outer face between the blocks, both above and below, are closed by superimposed rows of carefully dressed small equally thin slabs (cm 1-2), inserted at the back of the blocks of the core material. The resulting structure is very neat and effective. It was not exposed to view but covered by thick plaster (cm 2-2.5 thick).

The same pattern is found in the upper bodies. Also the material used is the same: fine-grained gneiss for the blocks, phyllite (dark schist) for the slabs. The schist is used for the base mouldings (torus, cavetto) and for the projecting support slabs; for the moulding in the few conserved elements (2nd storey) was used.

The core is composed of large and small schist fragments laid flat in a relatively regular horizontal direction, tending to form denser and more pronounced rows corresponding to the mouldings and ground plan. In the section corresponding to the height of the wall the material is thrown in, as it were, in small fragments (stone working wasters); an abundant use is made of clay as a bonding agent.

1st Storey, Quadrangular in Plan

Only the S side is shown, where the land slopes steeply down towards the stream; conserved as far as the corners and up to a maximum height of 4.00; the base moulding, covered by the low walls of the fields, is visible as though in cross section.

It is covered with filling on the E and N sides. On the W side, where the land is terraced downwards, the W side and the stairway are not visible, the latter perhaps conserved in the filling which has been partially removed; in order to support the terraces and offset the differences in height, substruction walls have been built on the W and above all the S sides.

While none of the moulding is visible, the base was revealed in a short sondage made along the wall. It comprises the cavetto, made up of two schist slabs, three-faced torus, consisting of two schist slabs, the upper one of which including the upper face; then the plinth, comprising two rows of gneiss blocks and slabs forming also its top below the torus. The base is supported by a projecting row of schist slabs with a small foundation wall to even out the underlying platform of small flat stones, which no doubt formed the missing bed of slabs of the floor certainly supported by the substruction wall at the edges.

The excellent plaster work, 2-2.5 cm thick, is conserved on the plinth and partly below the torus, which takes on a curved profile. A thin second coat has been applied to the lower part of the plinth, which extends down as far as the grade plane on the foundation slabs.

2nd Storey, Circular in Plan

Set back by 2.60 with respect to the 1st storey, it retains several features comprising part of the wall, the base, the projecting foundation slabs and, partly, a short section of the moulding. The base repeats the profile of the lower one and dark schist is used in the torus mouldings of the cavetto. They are each composed of two slabs corresponding to half their height. The remains of the moulding consist of three lower rows of thick gneiss slabs separated by two thinner ones, also made of gneiss, the profile of which has not been conserved as a result of heavy corrosion; the upper part of the moulding is missing. The maximum conserved height is 0.32, while the total height up to the overlying storey is c. 0.50. The profile may well have been of the ovolo, cavetto, reverse ovolo and coping slab type.

On the W of the ruined stupa, which is particularly wide on this side, lie the remains of the stairway and its projection. The lower part of the latter is conserved on the S side, together with a short stretch of wall, the base and the foundation slabs (projecting by 0.05). The wall terminates at the corner in which it joins the

main body, while the base socle continues as far as the point where it meets the ramp of the stairway. A set of well connected blocks, although with undressed surfaces, make up the front of the projection supporting the stairway structure, linked together by several blocks projecting from the front itself.

The stairway, now completely lost, contained another one of which a few of the initial steps remain. It has a wall made up of blocks and small slabs, carefully laid but roughly finished.

The width of the stairway is determined by the cuts in the base (projecting slabs, torus, cavetto). The distance between its wall and that of the inner stairway is 0.50. It is c. 1.50 wide.

Plaster traces are visible on the projection and descend as far as the foundation slabs; there are also traces on other parts, in the mouldings (torus).

This internal structure is found also in Butkara I, Panr I and Saidu Sharif I. In all probability its function was related to work on the building site. It afforded access to the upper parts of the monument to transport materials after the 2nd storey had been constructed.

3rd Storey, Circular in Plan

A short stretch with base and wall still remains. The base has a cavetto and torus, each made up of two slabs; the torus is divided into two halves. The wall has been conserved up to a maximum height of 0.31. It is set back with respect to the wall of the underlying storey by 1.30. The cornice was intended to continue the profile of the underlying one with a coping slab.

4th Storey, Circular in Plan (Drum) and 5th Storey, Raised Dome with Internal Structures

Only the core, without its facing, rises above the 3rd storey. It corresponds to the 4th and 5th storeys (drum and dome).

The 4th storey, present without any doubt, is executed with the same diameter and height as the 3rd, although lacking the base and with a probable cornice of the same size without coping slabs.

The 5th is the dome of the same diameter. Just below the still conserved top of the core, at the centre, lie the remains of a peculiar structure. The latter consists of two rooms, at an angle and with different heights. The lower room is rectangular in plan with the longer axis running N-S, the floor made of beaten earth (?) and walls made of blocks. It narrows towards the N on the E side to form an oblique stretch; to the S it forms an angle facing E; it is impossible to ascertain where the two extremities end. A short section of the walls has been preserved on the S, W and

E sides; the cracks and gaps left by the missing parts reveal the surrounding core.

Corresponding to the section facing E, at a greater height (1.03), runs a narrower corridor, thus maintaining the N side level with the same side of the lower room and the S side on a more internal line. It is now possible to ascertain where the two extremities end; the one on the E side is interrupted where the structure is missing.

Owing to the very poor state of conservation the plan and elevation of the two rooms cannot be determined, nor their reciprocal ratio, if any, or their function. Hypotheses may be advanced on the basis of comparisons with several stupas investigated by Ch. Masson (Wilson 1841: chap. II, 55-118) with the presence of internal corridors: Tope Gudara, Wilson 1841: pl. IV; Foucher 1905-51: fig. 19; Tope no. 4 of Chahar Bagh, Wilson 1841: pl. VI; Darunta tumuli, *ibid.*: pl. V.

An example comparable to this peculiar structure, although on a much smaller scale, is what remains of stupa 38 of Saidu Sharif I (Faccenna 1995a: 284, fig. 101); at the height of the 2nd storey, circular in plan, it starts from the outer wall and reaches the central reliquary box (h. 0.12, width. 0.09, length 0.60, Period I, phase c, 1st half of 1st cent. B.C.-end of 1st cent. A.D.?).

Reconstruction

The description of the individual parts of the body of the monument provides us with elements on which to base its reconstruction (plan, elevation and axonometry). The reconstruction is based on the conserved parts and on the internal comparison of its structural parts. For the first three storeys we have the base moulding and in the 2nd storey the wall and cornice height. The now eroded profile that emerges from this as a plausible proposal may be applied also to the other storeys (1st and 3rd storeys). The broadest hypothesis is applied to the upper stories of which only part of the core has been conserved; its structure possibly suggests a correspondence between mouldings. The flight of steps of the 1st storey could consist of 28 steps with an inclination of 40°; that of the 2nd storey, 10 steps with a gneiss slab tread and an inclination of 41°. Also to be noted is the raised dome, the profile of which has been obtained by referring to what emerges from an examination of other Swat monuments.

It is reminiscent of the stupas of Tokar Dara, Gumbatuna and Saidu Sharif I in the number and proportions of the storeys. Gumbatuna has a single flight of steps, while they all have angular columns, which are absent at Gharasa (Faccenna 1995a: 502-25).



Fig. 2. Stupa of Gharasa (Dangram). NW general view. View of the 2nd storey with stairway, 3rd storey and overlying structures. (Kuwayama 1993).



Fig. 3. Stupa of Gharasa (Dangram). 2nd storey, W side. Stairway, corner of the wall of the 2nd storey and the S side of its projection. Also to be noted is the front side of projection and, on the left, the S side of internal structure of the stairway with its initial steps. (Kuwayama 1993).

A. Stupas



Fig. 4. Stupa of Gharasa (Dangram).
2nd storey, S side. (Olivieri 1991; Neg.
CS).



Fig. 5. Stupa of Gharasa (Dangram). 2nd storey, S side. (Olivieri 1991; Neg. CS).

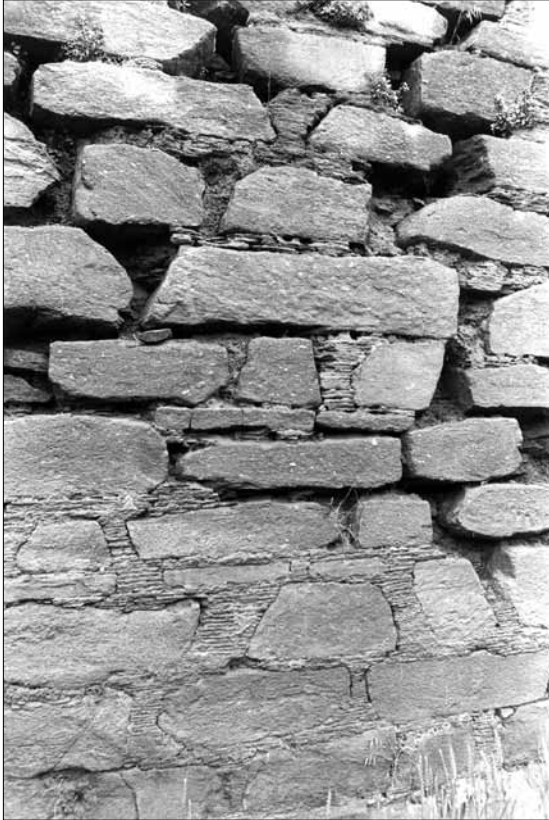

Fig. 6. Stupa of Gharasa (Dangram). 2nd storey, S side. (Olivieri 1991; Neg. CS).



Fig. 7. Stupa of Gharasa (Dangram). E general view. View of the 2nd storey, part of the 3rd storey and of the overlying structures. (Kuwayama 1993).

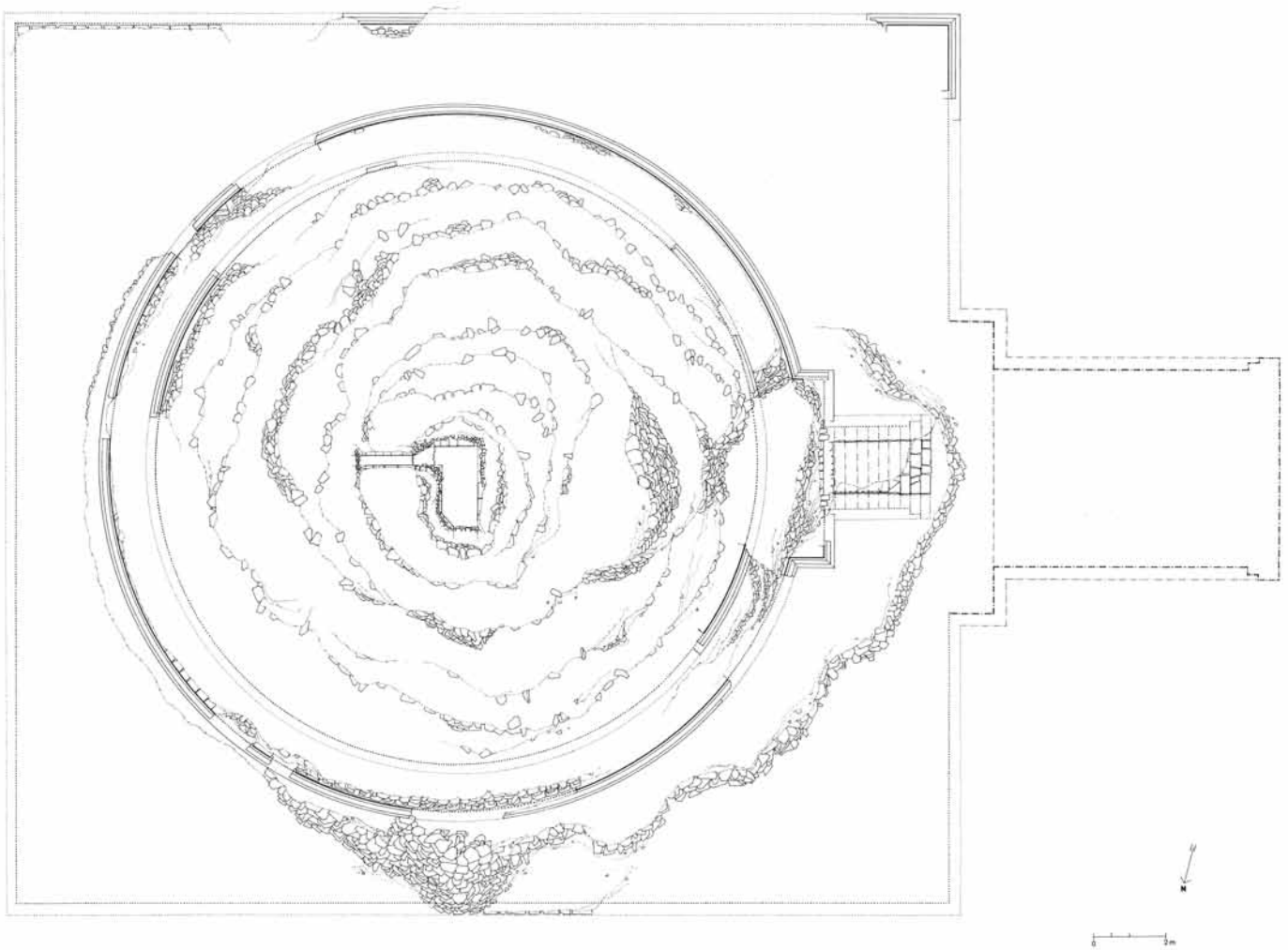

Fig. 8. Stupa of Gharasa (Dangram). Plan. (Sabelli 1993; Martore 2003).

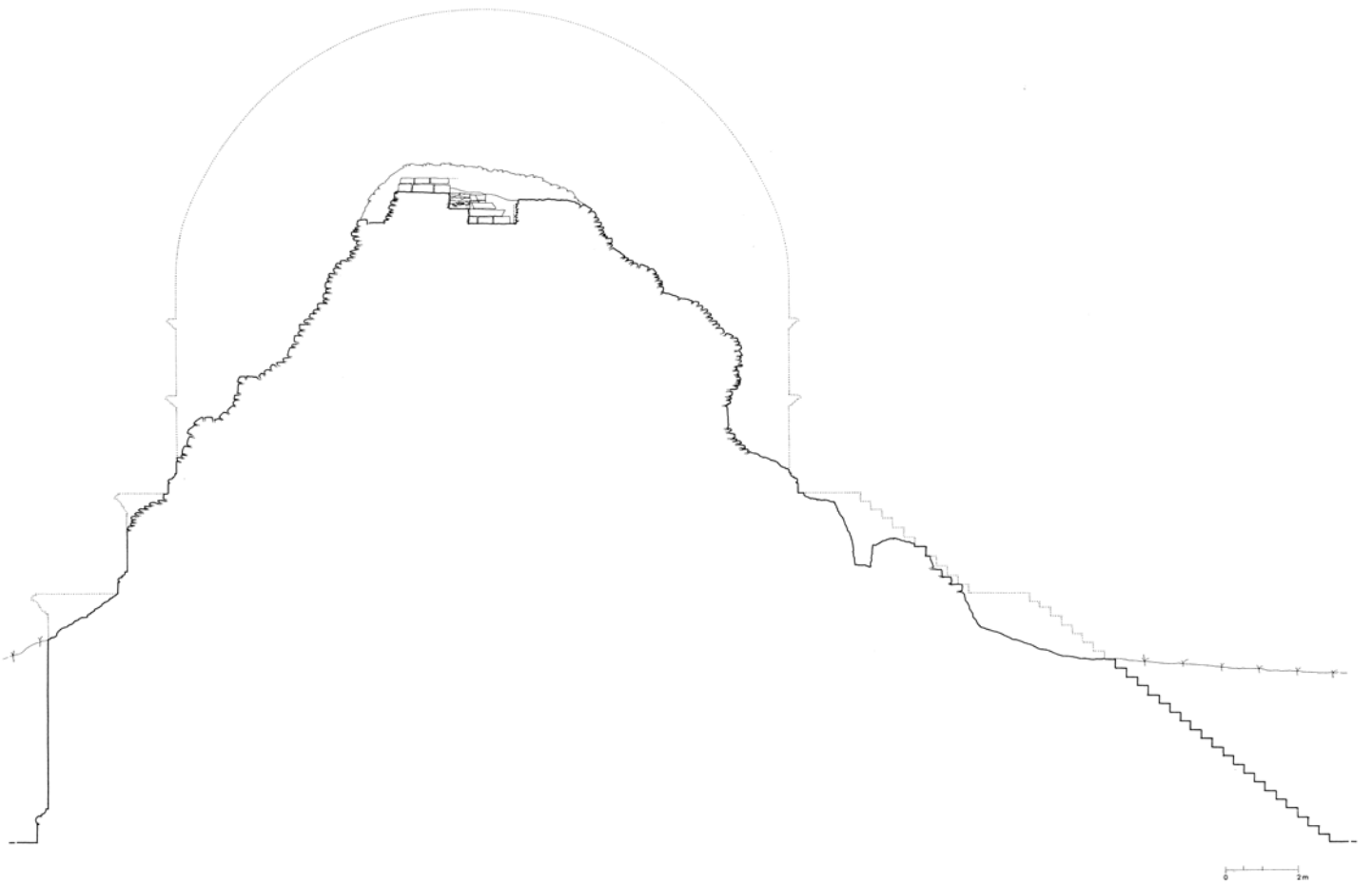

Fig. 9. Stupa of Gharasa (Dangram). E-W cross section. (Sabelli 1993; Martore 2003).

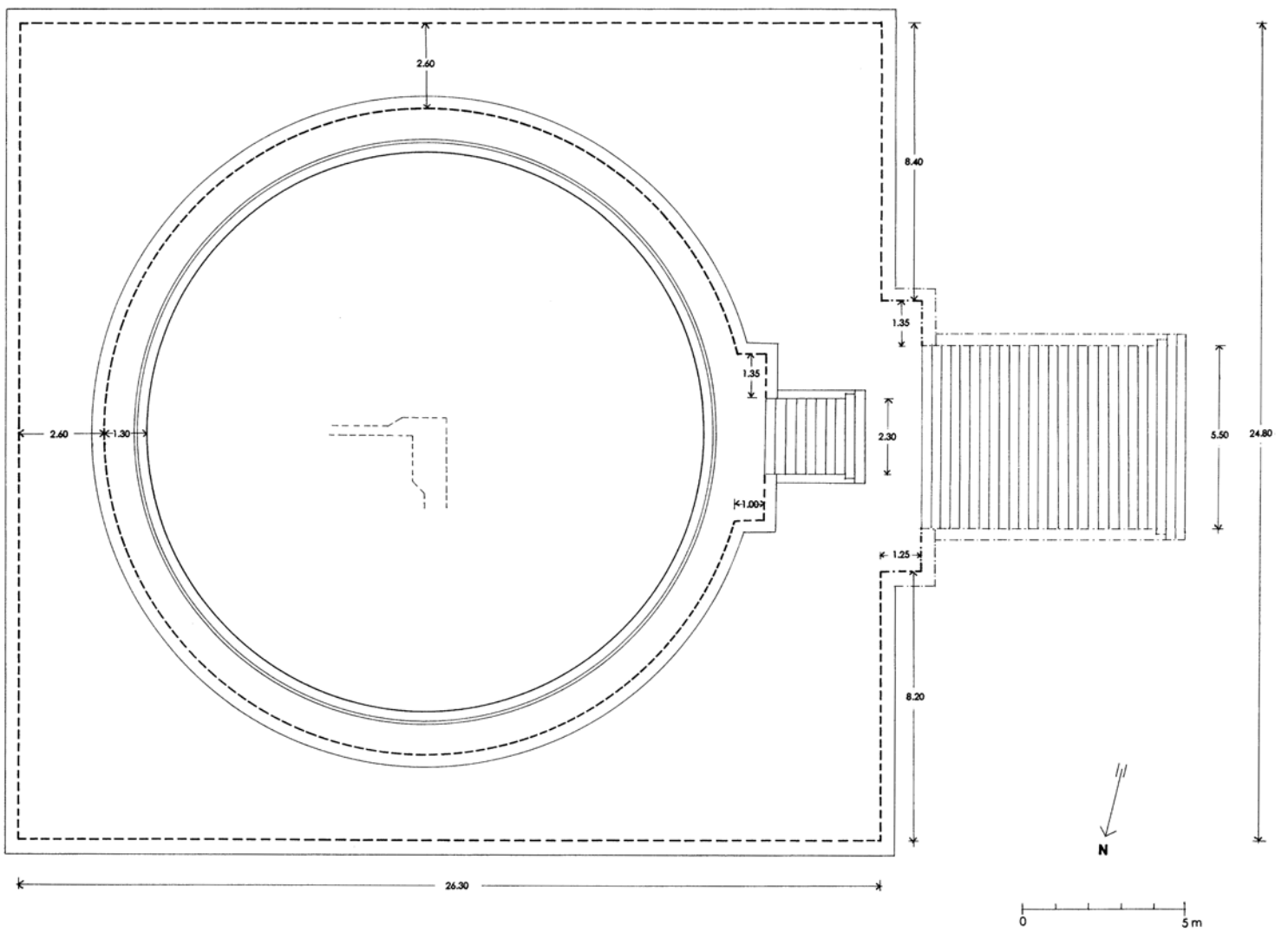

Fig. 10. Stupa of Gharasa (Dangram). Sketch plan showing the measures. (Sabelli 1993; Martore 2003).

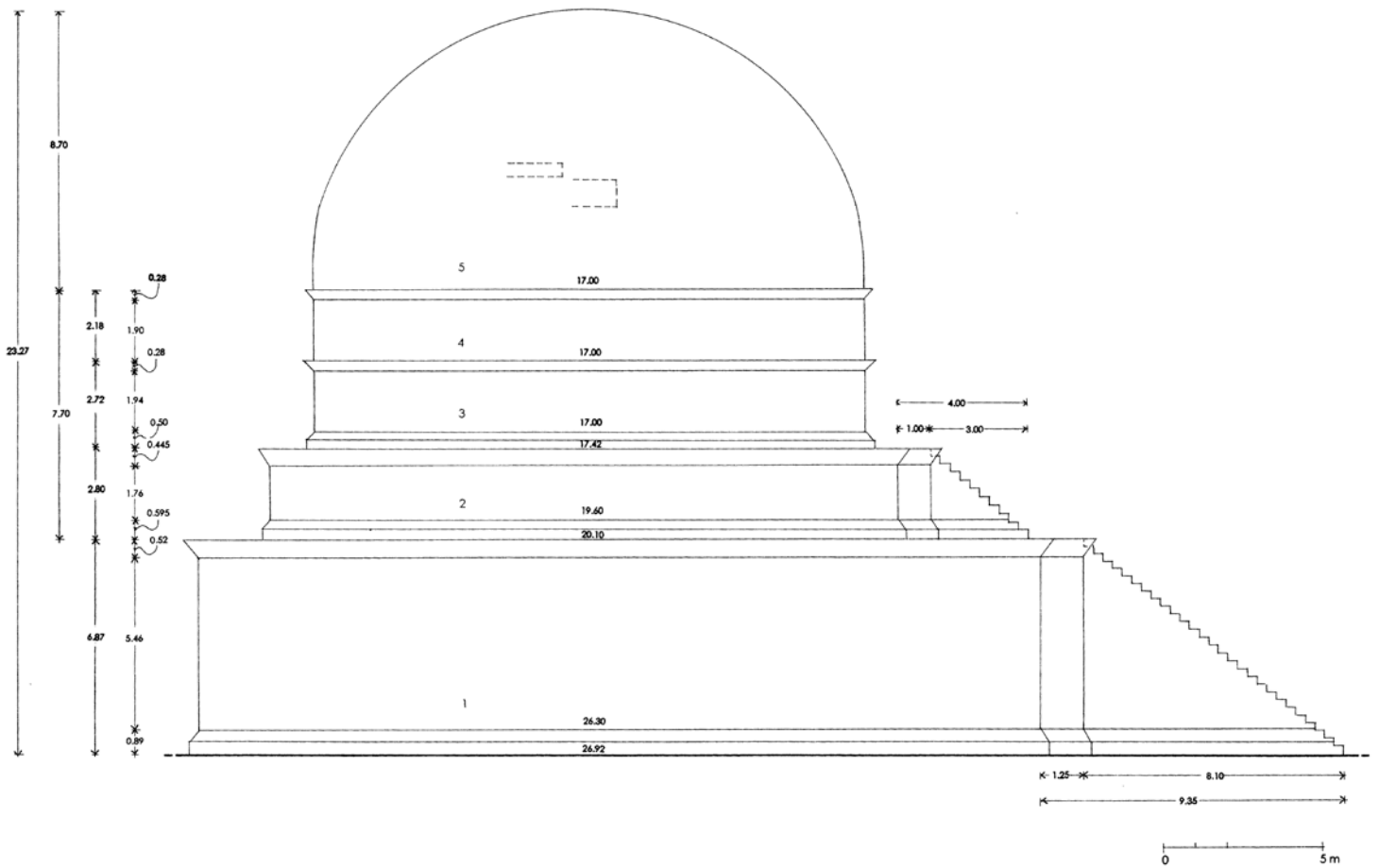

Fig. 11. Stupa of Gharasa (Dangram). Sketch elevation showing the measures. (Sabelli 1993; Martore 2003).

A. Stupas

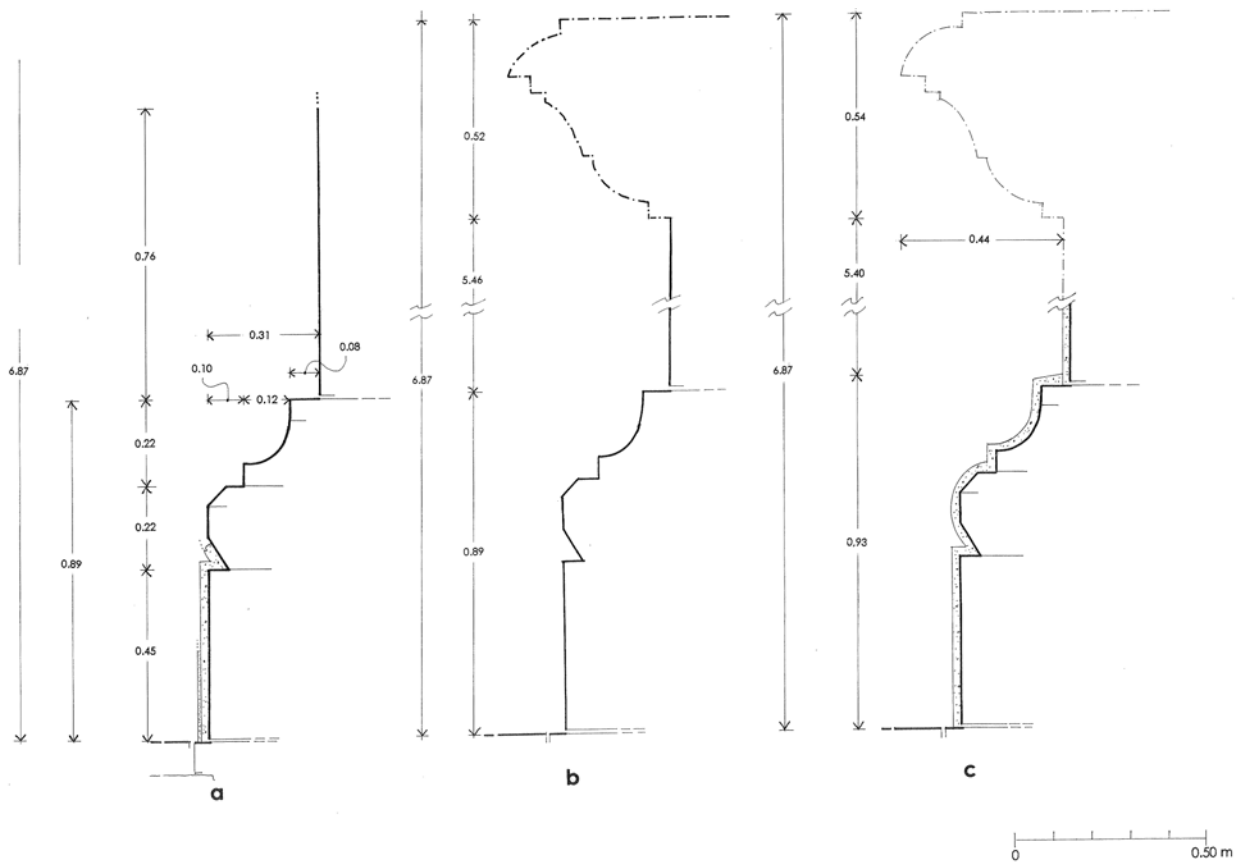

Fig. 12. Stupa of Gharasa (Dangram). 1st storey. *a.* profile. *b.* reconstructed profile, without plaster. *c.* reconstructed profile, with plaster. (Sabelli 1993; Martore 2003).

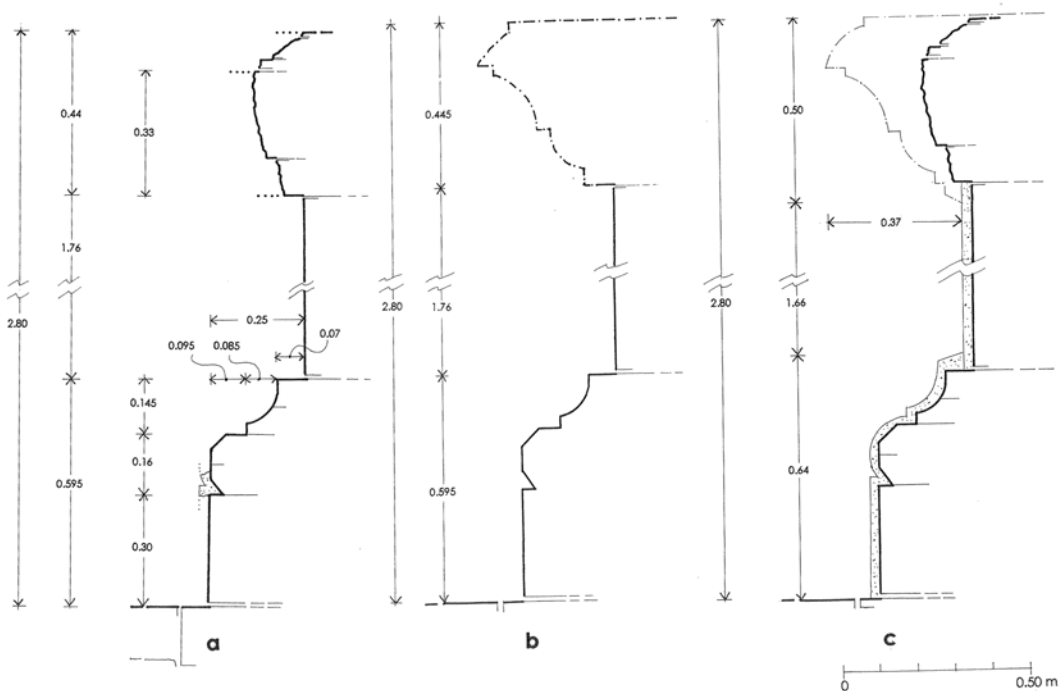

Fig. 13. Stupa of Gharasa (Dangram). 2nd storey. *a.* profile. *b.* reconstructed profile, without plaster. *c.* reconstructed profile, with plaster. (Sabelli 1993; Martore 2003).

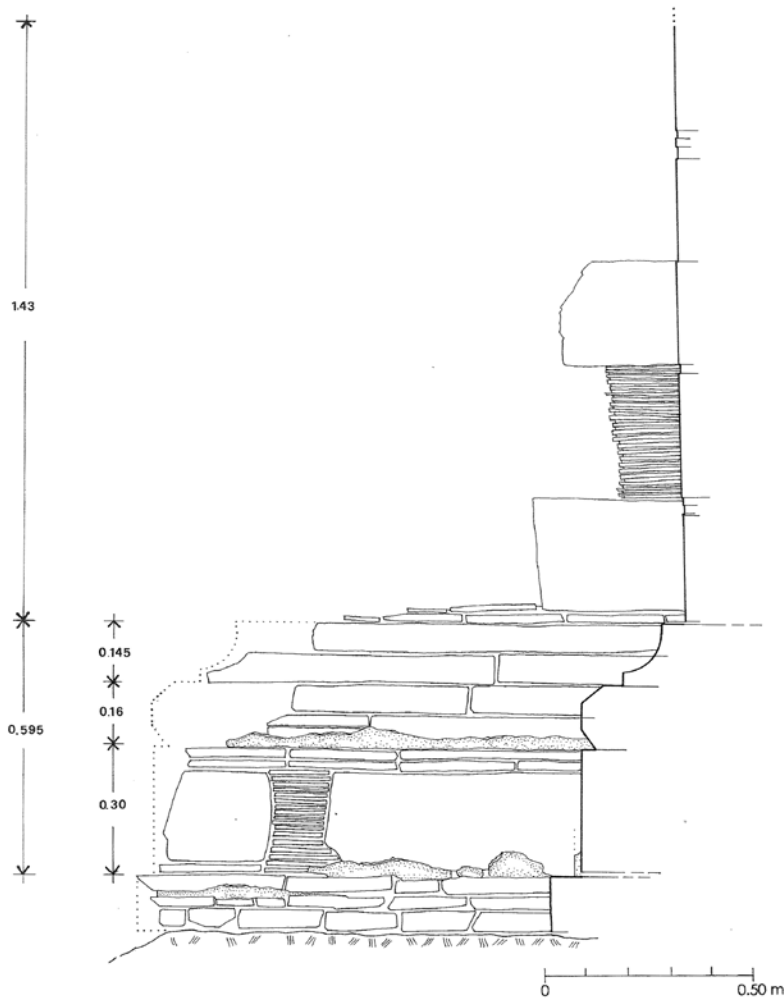

Fig. 14. Stupa of Gharasa (Dangram). 2nd storey. Stairway, S side of its projection. (Sabelli 1993; Martore 2003).

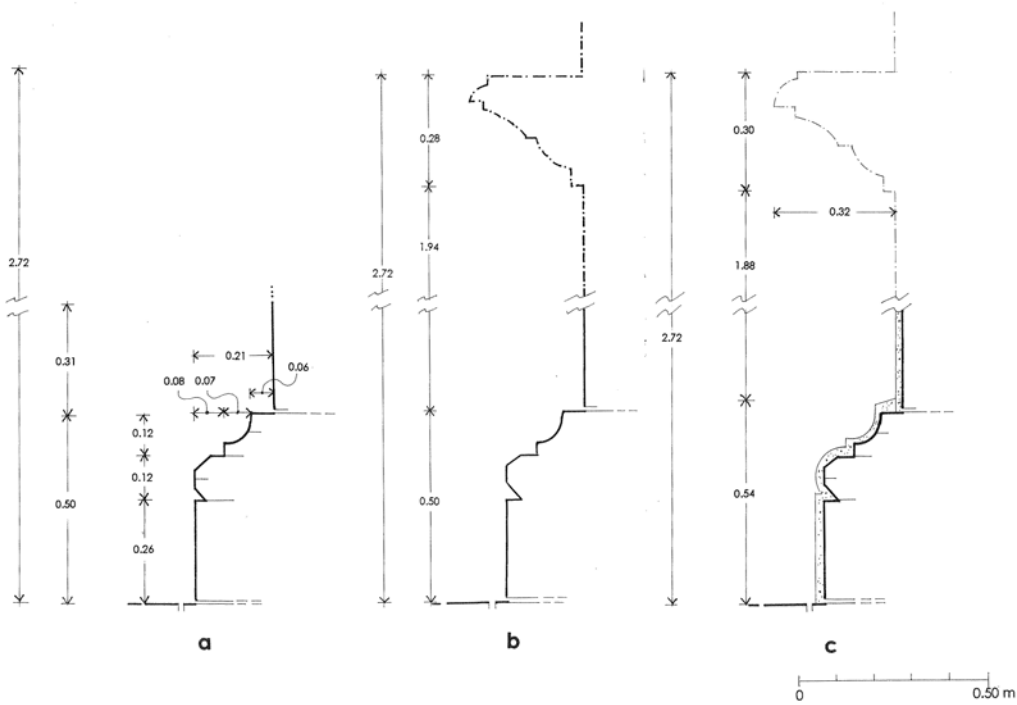

Fig. 15. Stupa of Gharasa (Dangram). 3rd storey. *a.* profile. *b.* reconstructed profile, without plaster. *c.* reconstructed profile, with plaster. (Sabelli 1993; Martore 2003).

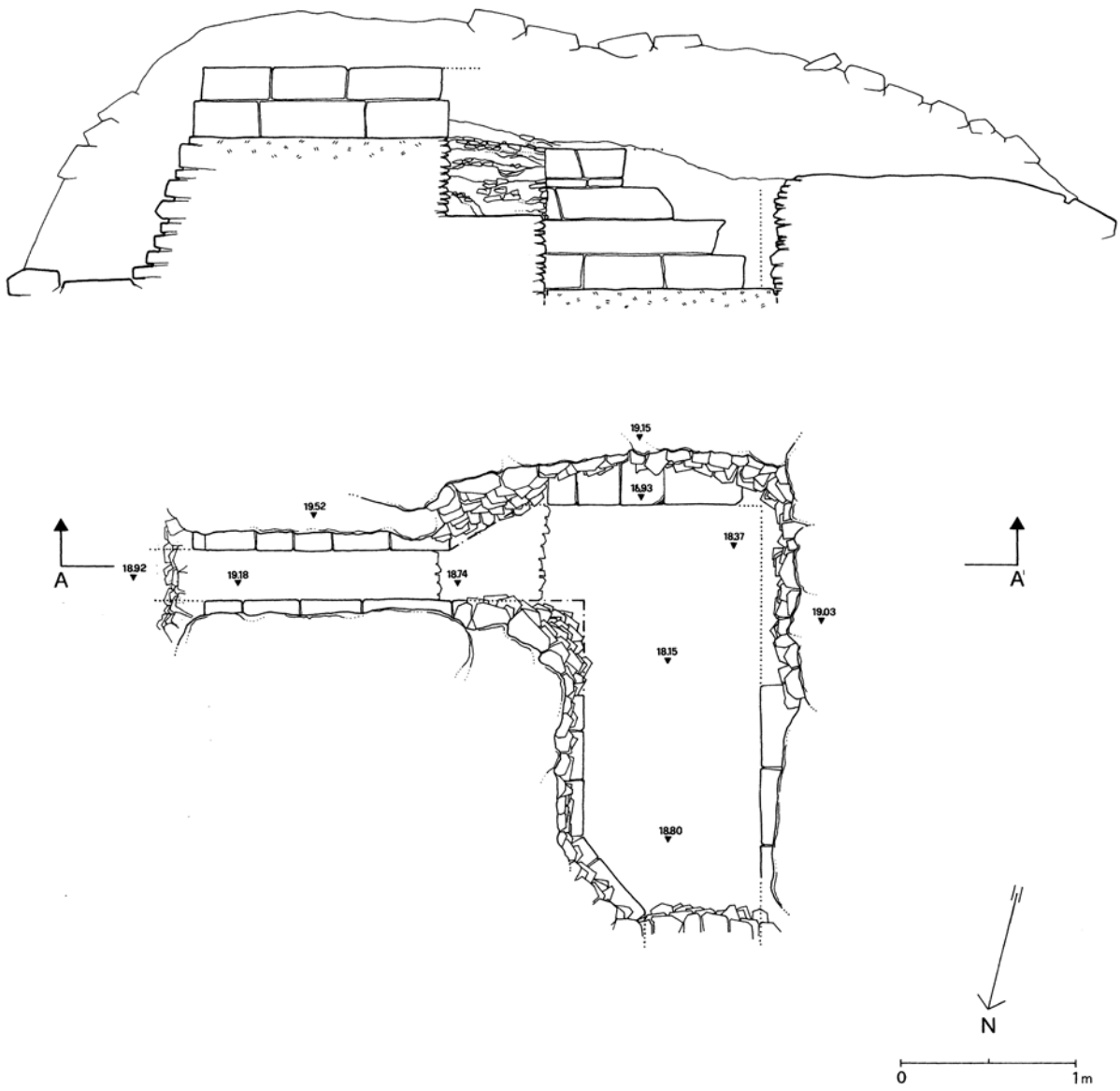

Fig. 16. Stupa of Gharasa (Dangram). 5th storey, dome. Internal structure; cross section and plan. (Sabelli 1993; Martore 2003).

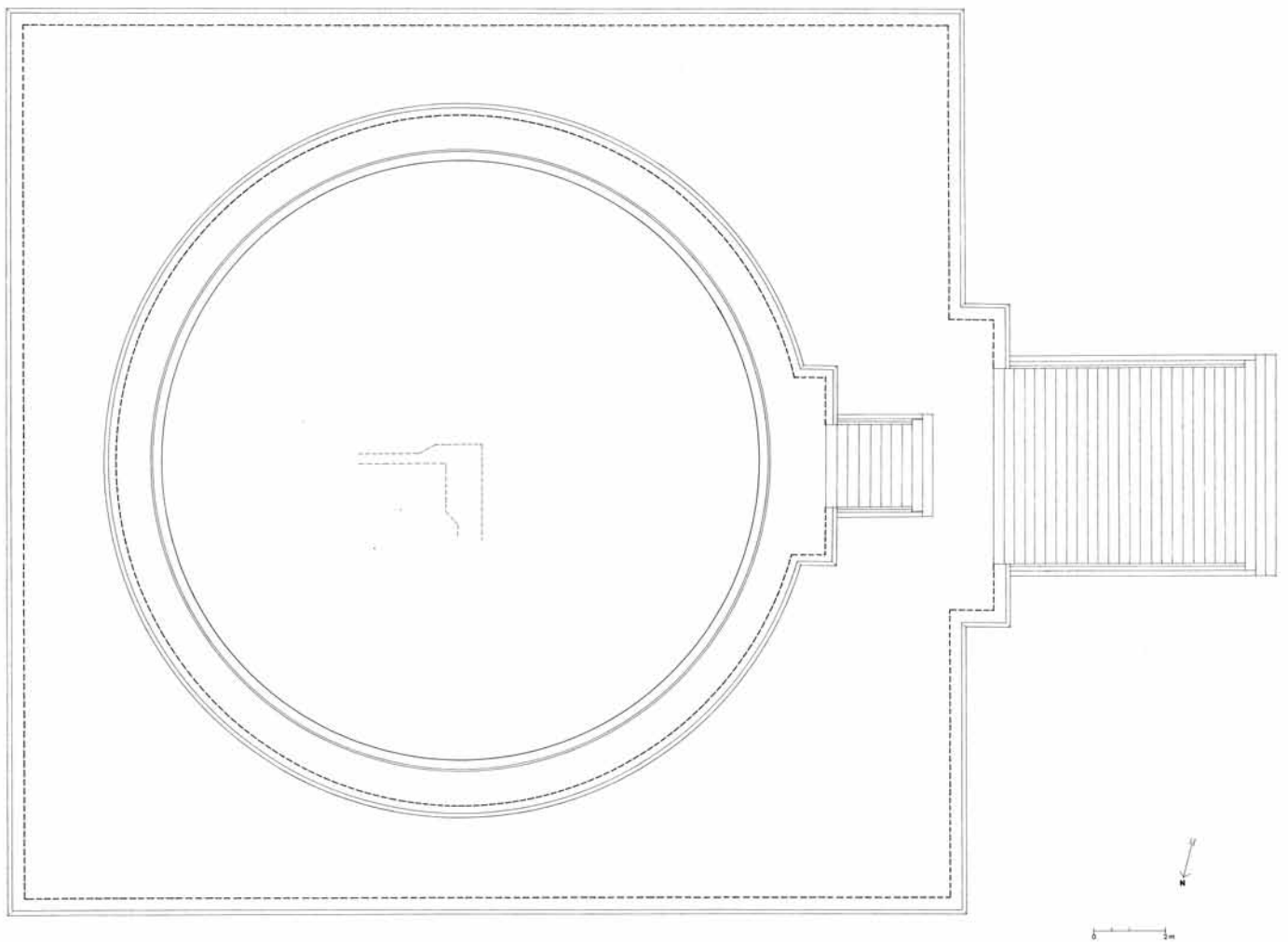

Fig. 17. Stupa of Gharasa (Dangram). Reconstructed plan. (Sabelli 1993; Martore 2003).

A. Stupas

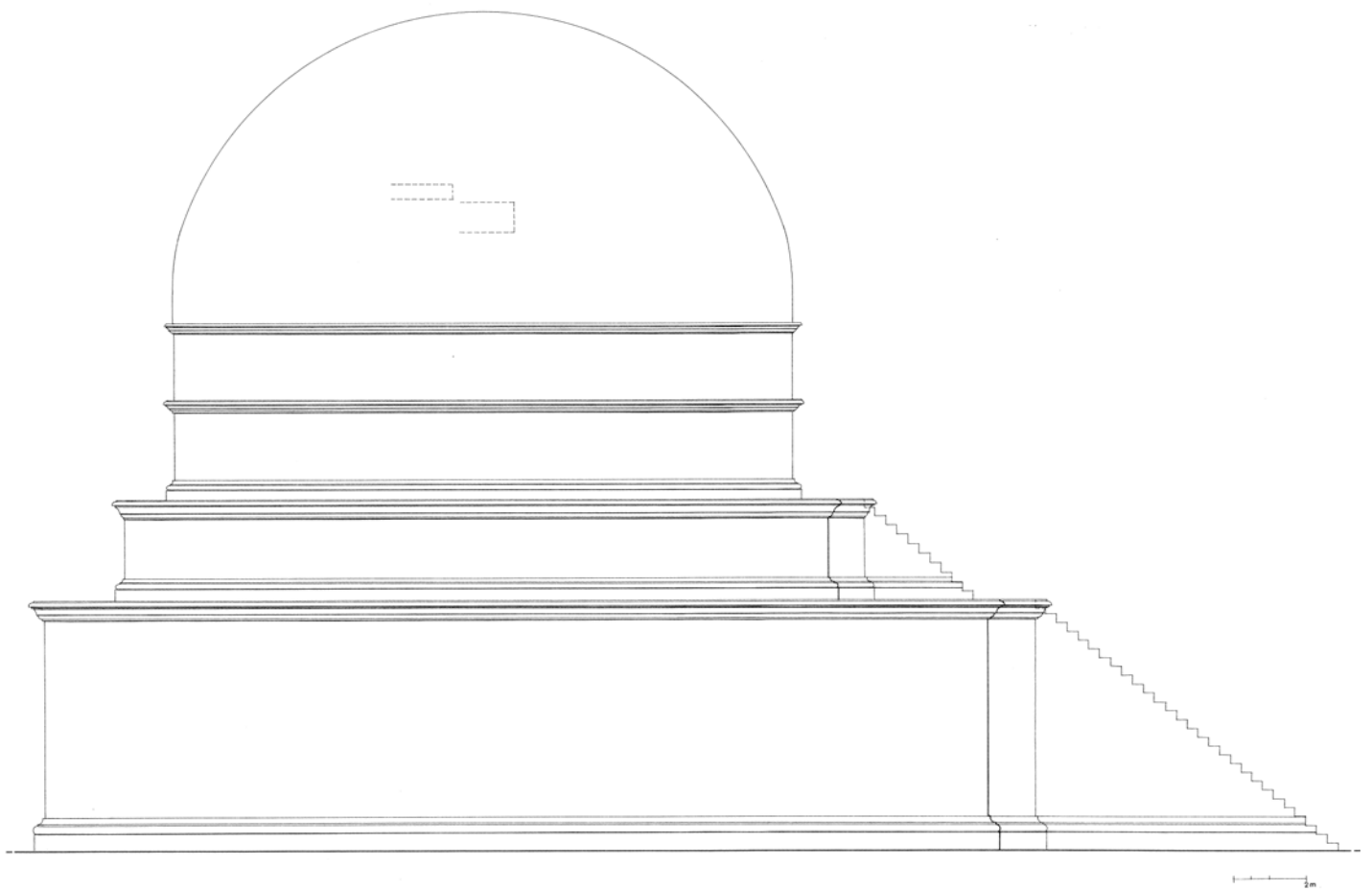

Fig. 18. Stupa of Gharasa (Dangram). Reconstructed elevation. (Sabelli 1993; Martore 2003).

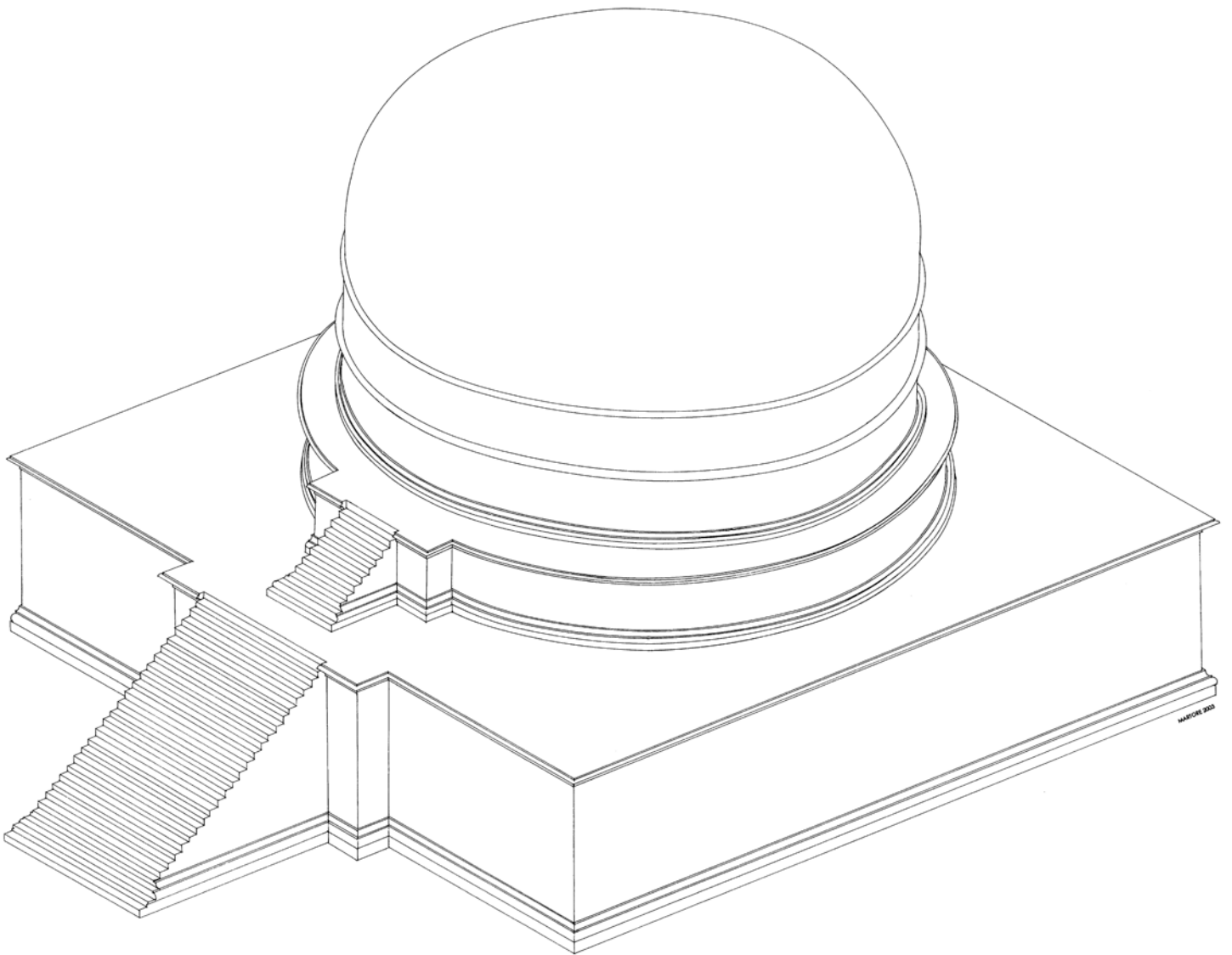

Fig. 19. Stupa of Gharasa (Dangram). Axonometric view. (Martore 2003).

A2. Stupa of Jurjurai

(Figs. 20-49)

The Site

Zone of Jambil-Saidu. Jambil Valley.

Position: Lat. c. 34° 43' N; Long. c. 72° 25' E; SPM 43 B/6.

After arriving from Mingora, on the left bank of the Jambil River, a short steep climb leads to the Stupa of Jurjurai. It is located on this side of the valley, like the other stupas of Loebanr and Arapkhanchina, with which it is also aligned, on a cliff on Mt Tor Kamar which closes it to the rear. To the E the land slopes steeply down towards a stream at the valley bottom from which it gets its name Jurjurai kanda, abounding in water, a tributary of the Jambil.

From here it overlooks the valley; in front, on the other side of the river, the village of Dangram and the Gharasa area with the stupa are clearly visible.

The mountain is dotted with large round blocks of gneiss.

Bibliography and Documentation

Stein 1929: 74, fig. 43 ⁽¹⁾; 1930: 46, fig. 28, pl. 7 ⁽²⁾.

Taddei 1958, 1959: photographic reconnaissance.

Gui and Cimmino 1964-1965: reconnaissance and report.

Faccenna 1980-1981: 755, n. 2.

Olivieri 1989: reconnaissance with photographic documentation (in Filigenzi 2014).

⁽¹⁾ 'There were numerous Buddhist ruins also in the Jambil valley [...].'

⁽²⁾ 'Continuing in the same direction for another half mile the large ruined Stūpa of Jurjurai (fig. 28) was reached just opposite to the village of Dāngrām. It, too, had suffered badly by digging for treasure and by quarrying, but preserved the facing masonry of large slabs at least on portions of dome and bases. Of the latter there were, as the sketch plan (pl. 7) shows, three, the lowest measuring 53 feet square. This as well as the two upper circular bases were decorated with pilasters about one foot wide; these, however, in most places are now marked only by the 'matrices' they have left at their back. The dome broken on the top appears to have measured about 33 feet in diameter'.

Olivieri 1991: reconnaissance with description and photographic documentation.

Nascari 1992-1993: reconnaissance with description and photographic documentation.

Sabelli 1993: graphic survey.

Martore 2003: control, corrections, updating of graphic part and symbols.

Spagnesi 2005: photographic inspection.

The Stupa

The stupa is composed of a storey that is quadrangular in plan, two gradually retreating circular storeys, the second of which is the drum, and the raised dome. The walls have pilasters. On the E side it has a stairway, a projection and a flight of steps, referring to the 1st and 2nd storeys.

On the stairway side the ground falls away steeply; substruction walls are probably also present. A short distance to S the cliff rock is cut away to provide room for the monument's construction. On the N side there must have been smaller stupas; there are no longer any traces of the monastery buildings which nevertheless must have existed.

The stupa was apparently quite isolated. The outer surface and the core have been badly degraded and on the W side of the latter there is a gap with a well in the middle. This degradation is also the result of the excellent quality of the dressed stone blocks and the other material of which it was constructed, which could easily be reutilized. The external surface of the 1st storey is visible on three sides, while the fourth side, facing the mountain, is covered by collapsed material. Its upper part with its capital and cornice is thus missing. Parts of the 2nd and 3rd storeys remain, the latter retaining also a very short portion of the cornice. Only the core continues above this. The stairway has lost its steps and the front part.

The construction technique used for the wall consists of blocks surrounded by thin slabs. The blocks are made of augen and minute grained gneiss; they consist of large parallelepiped blocks, above all in the 1st storey, gradually decreasing in size towards the top; they can also reach 1.00 and more in length, with a height of 0.35, sometimes occupying the entire space between the pilasters. Their upper and lower surfaces are flat, with variously sized sides; they are placed close together so that the intermediate space for the thin slabs both above and below is much reduced. Also the thin slabs are made of gneiss.

The core is made of closely spaced gneiss blocks laid in horizontal rows and thinly bonded with clayey earth.

1st Storey, Quadrangular in Plan

It has a scotia base, visible over short sections, with each element carved out of a slab. The three-sided bevelled torus and the three-filleted scotia, together with the plaster covering them, take on the profile of a plain torus and scotia. The cornice is missing. The wall, made of large blocks (several of which as long as the space between the pilasters), is decorated with ten pilasters (including the corner ones) which are visible on the N and W sides, four on the E front, at the sides of the stairway. The projection, the front wall of which runs obliquely (a peculiar solution) has inner and outer angular pilasters and a half pilaster on the front where it joins the flight of steps. The interaxis distance between pilasters varies from 1.70 to 2.11, with the shorter distances on the front and the larger ones, except in a few cases, on the other sides. To be precise, the shorter interaxes (1.70, 1.80, 1.85) are found on the front, four on the right and left of the stairway for a length of 5.80 and 5.85, respectively, as well as on the opposite W side (except for three cases of 1.90 and 2.05) where they number ten for a length of 16.95; the longer interaxes are found on the N and S sides (except for a few cases 1.70 and 1.85 long), retaining the same number of ten interaxes for a length of 18.13, 18.35.

The scotia type base has been obtained from a single block; the structure, no longer distinguishable due to heavy corrosion, is defined by the plaster, small traces of which still remain.

The shaft is made up of blocks of varying height, extending alternately right and left to form the wall, with occasional slabs closing the intermediate gaps. Some 0.27 wide in the conserved upper part, it projects 0.03 from the wall; the upper part with the capital is missing and it may be assumed to have been provided with a modillion on the strength of what has been conserved in the 3rd storey.

On the conserved top, note should be taken of two large adjacent blocks of the flight of steps on the S side; the blocks are quite long (leng. 1.00, h. 0.31; leng. 1.25, h. 0.32) and of excellent workmanship.

2nd Storey, Circular in Plan

Set back 1.53 on the side and 1.66 at the rear, it is supported by projecting slabs with a small foundation wall. It repeats the motives of the storey below. It has an equal scotia type base; in one section there is a row of blocks that alone form the plinth of the base. The plaster has not been conserved.

The wall is evenly divided by pilasters with a scotia type base; on one side the mouldings are more visible while they are more severely corroded elsewhere. The upper part of the storey is missing.

The beginning of the core is all that is left of the stairway. Elements remain from

which the width and the length can be calculated. As in the 1st storey, it presents the front side of the oblique projection. The inner angular pilaster has been conserved, but only on the circular wall; it does not continue on the projection side, thus repeating the situation of the front part of the 1st storey.

3rd Storey, Circular in Plan (Drum)

Set back some 1.17, it repeats the motifs of the lower storeys, taking on a specific singularity as a drum. The blocks are smaller in size. The base has a simplified scotia reduced to a single fillet.

In the wall the pilasters are marked by the gaps left by their removal. The remains of two bases have been considered and one, the only one still complete although corroded, still displays the scotia that has also been simplified into a single fillet. Also a short stretch of the upper part of the pilaster with the modillion has been conserved; a section of it is visible to the right of the gap left by a capital. It consists of a single slab with three progressively projecting fillets with a recess in the lower face. On the right of it the fillet motif is set back towards the rear but then projects back outwards, forming part of the left half of the following right hand modillion. It is considered likely that the same element was present in the pilasters of the underlying storeys. Above this is the architrave with three gradually projecting bands towards the top; this is followed by an ovolo and a reverse cavetto. The cornice above is missing but was certainly composed of a reverse ovolo without any coping slabs; perhaps one or two of the upper slabs may be the slabs often found at the base of the dome, projecting only slightly from it.

4th Storey, Raised Dome

Practically flush with the wall of the 3rd storey the raised dome, lacking the base, is conserved for a short section (h. 1.52). It is clearly visible in Stein's photograph which shows the N wall of the stupa with the short conserved section of the 3rd storey. Part of its core rises above this.

Chattravali Disc

Along the N side of the stupa a gneiss disc lies edgewise and half buried in the corner of a structure, certainly a smaller stupa. It has a diameter of 1.94, with a hole through the centre and two other holes visible on the perimeter; it has a sloping edge and one of the faces, left slightly undressed, slopes gently downwards towards the edge.

As far as the size and location of the find are concerned, it probably belonged to the Main Stupa.

Reconstruction

The Stupa of Jurjurai with its quadrangular plan storey and the two circular storeys above it, the second of which is the drum, the dome on top, the stairway aligned along an E axis corresponding to the 1st and 2nd storeys, its pilaster decoration on all the storeys, the size and the relations between them are extraordinarily similar to the Stupa of Loebanr (see no. A3).

Also the number of pilasters is the same in the 1st storey, varying in the 2nd and 3rd storeys. They differ on the front: there are four at the sides of the stairway, four in the 1st storey, one in the 2nd.

The projection is different. In the 1st and 2nd storey the projection runs slightly oblique to the pilaster in the 1st storey, both inner and outer angular ones, with the additional pilaster in the corner adjacent to the body of the stairway and in the 2nd storey only the inner one. The stairway of the 1st storey may have 19 steps with an inclination of 40°, that of the 2nd storey 10 steps with a steep inclination of 48°.

Pilasters of differing sizes may also be observed in the 1st storey; this is due not only to the different side lengths but probably also to some other indeterminable reasons.

The effect of overall compactness of the total volumes is due also to the excellent masonry technique consisting of large carefully dressed and snugly fitting blocks which left little need for any small transition slabs, thus offering a strong impression of solidity and beauty not found in other similar monuments.

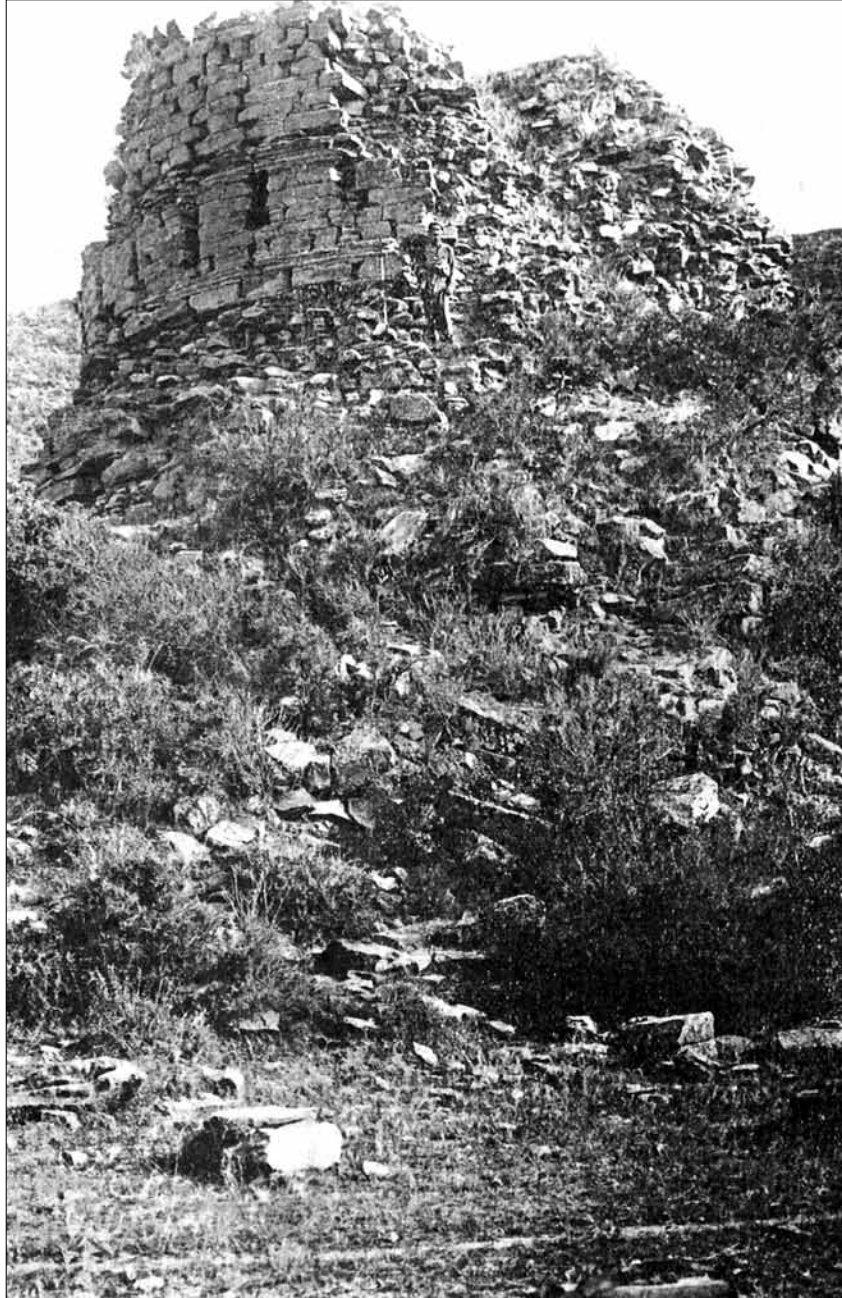

Fig. 20. Stupa of Jurjurai. NW general view. (After Stein 1930: fig. 28).

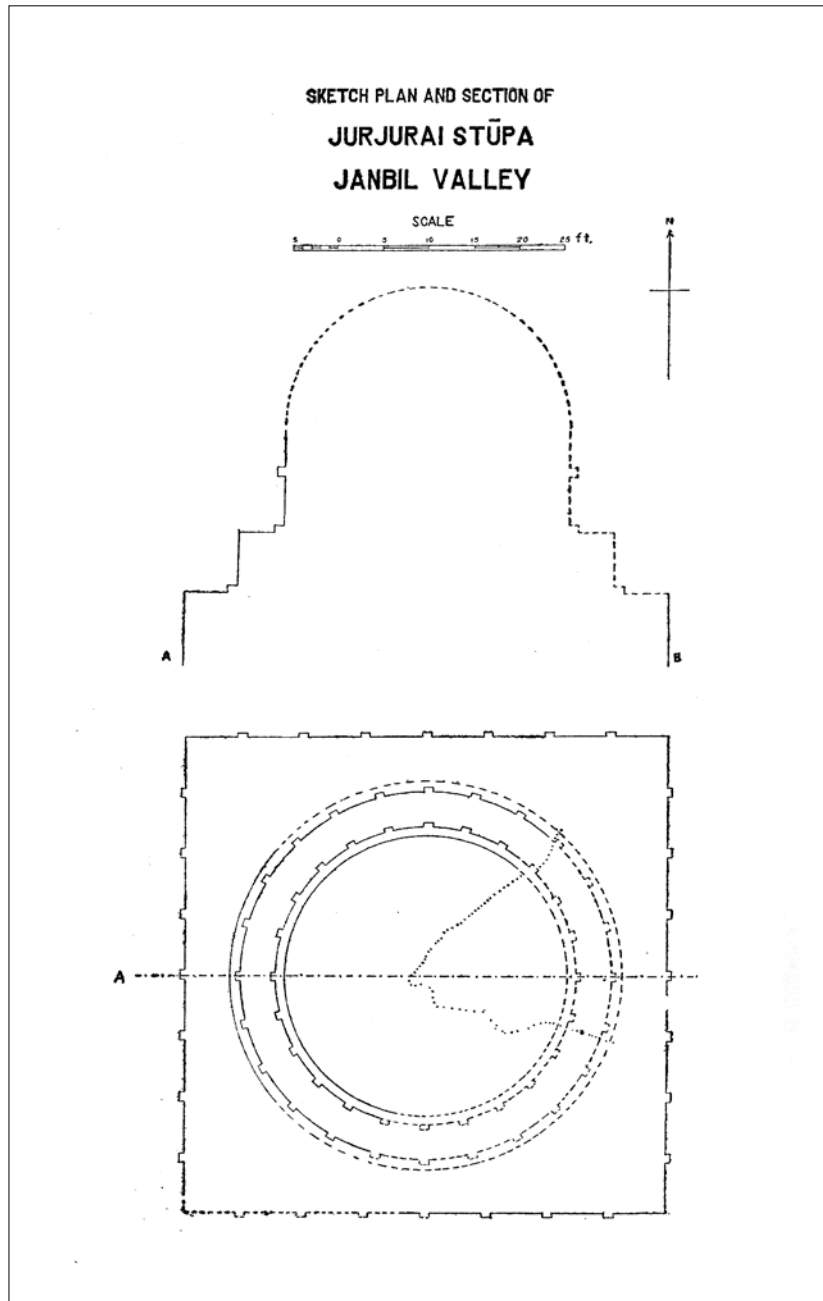

Fig. 21. Stupa of Jurjurai. Sketch plan and cross section. (After Stein 1930: pl. 7).



Fig. 22. Stupa of Jurjurai. General view from S. (Taddei 1958; Neg. CS).

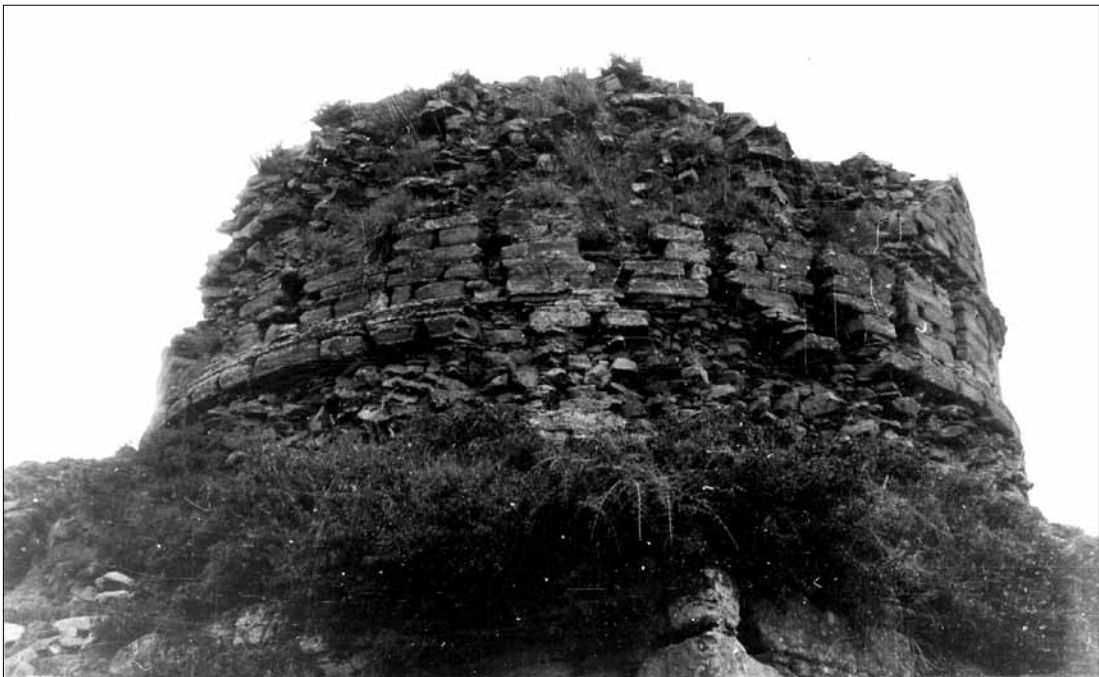

Fig. 23. Stupa of Jurjurai. General view from S. (Taddei 1958; Neg. CS).

A. Stupas

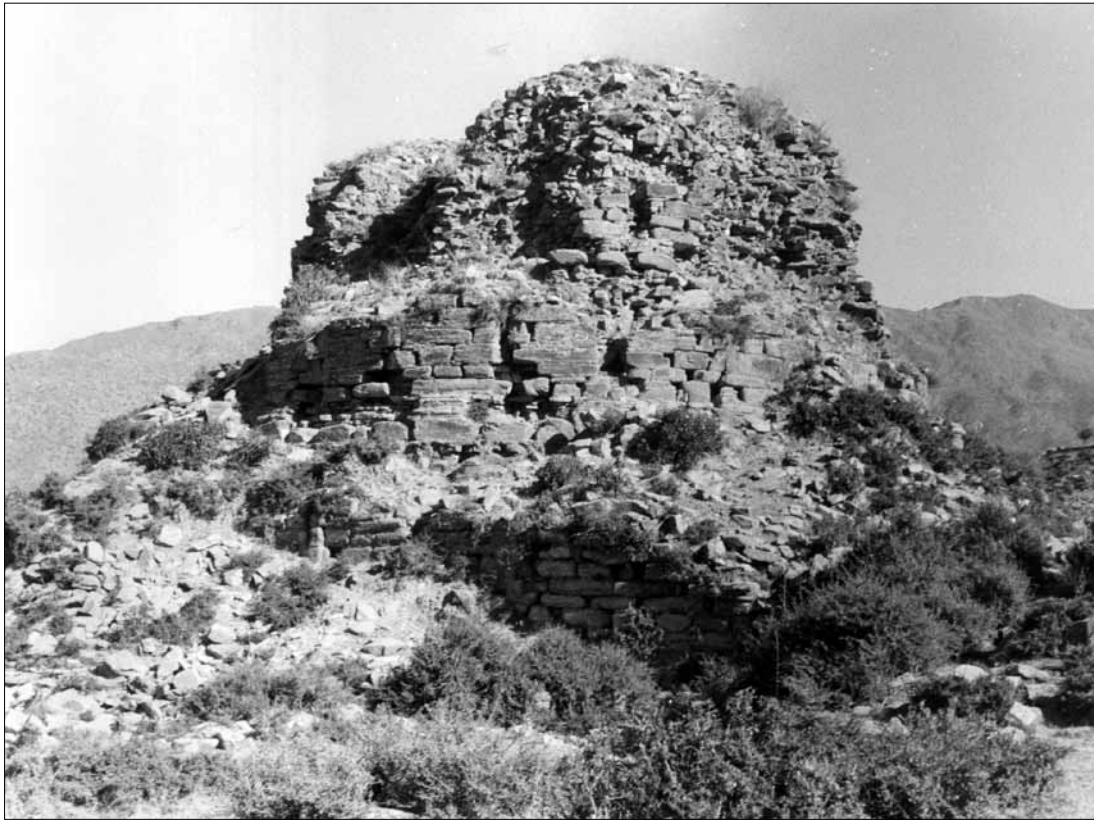

Fig. 24. Stupa of Jurjurai. View from W; on the S of the cut through the dome. (Taddei 1969; Neg. CS).



Fig. 25. Stupa of Jurjurai. General view, E side; stairway on the right. (Nascari 1993; Neg. CS).



Fig. 26. Stupa of Jurjurai. 1st storey, S side of the stairway, detail of blocks of the wall. (Olivieri 1991; Neg. CS).



Fig. 27. Stupa of Jurjurai. General view, E side; on the right of the stairway. (Olivieri 1991; Neg. CS).

A. Stupas



Fig. 28. Stupa of Jurjurai. General view, W side. (Nascari 1993; Neg. CS).



Fig. 29. Stupa of Jurjurai. 1st storey, detail. (Spagnesi 2005).



Fig. 30. Stupa of Jurjurai. 1st storey, detail of a corner with pilaster. (Spagnesi 2005).

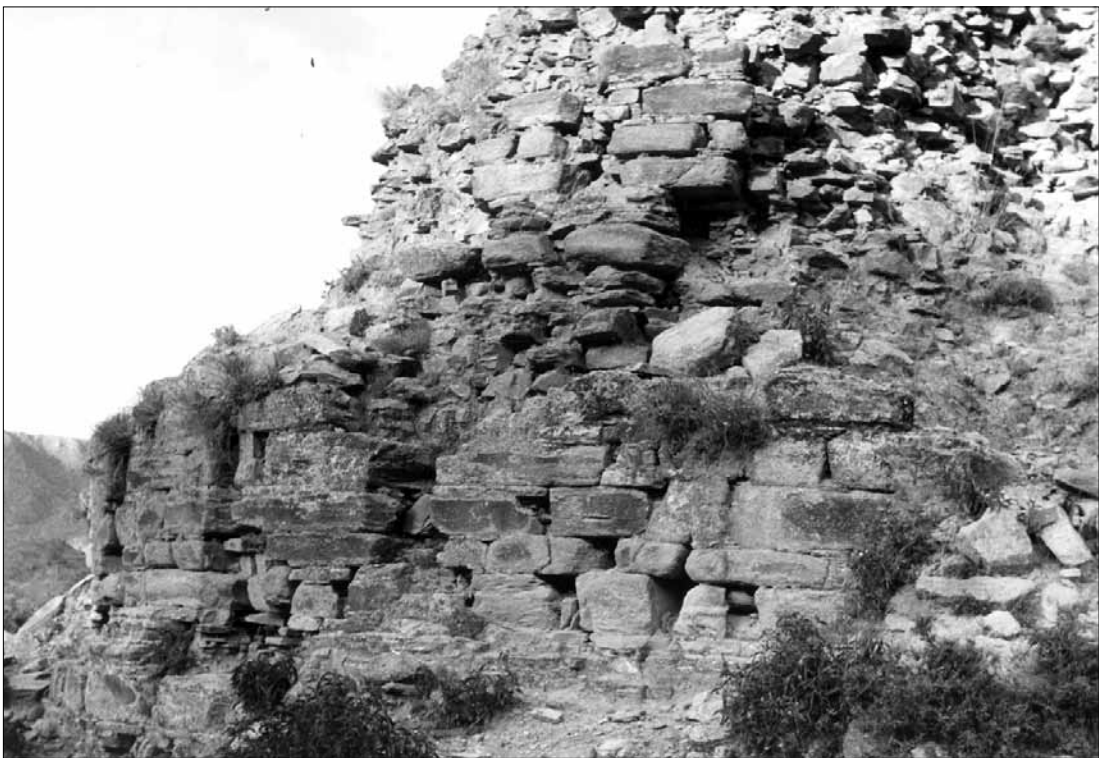

Fig. 31. Stupa of Jurjurai. 3rd and 4th storey. (Taddei 1958; Neg. CS).



Fig. 32. Stupa of Jurjurai. 3rd and 4th storey, profile. (Taddei 1958; Neg. CS).



Fig. 33. Stupa of Jurjurai. Detail of the base of the 3rd storey. (Taddei 1958; Neg. CS).

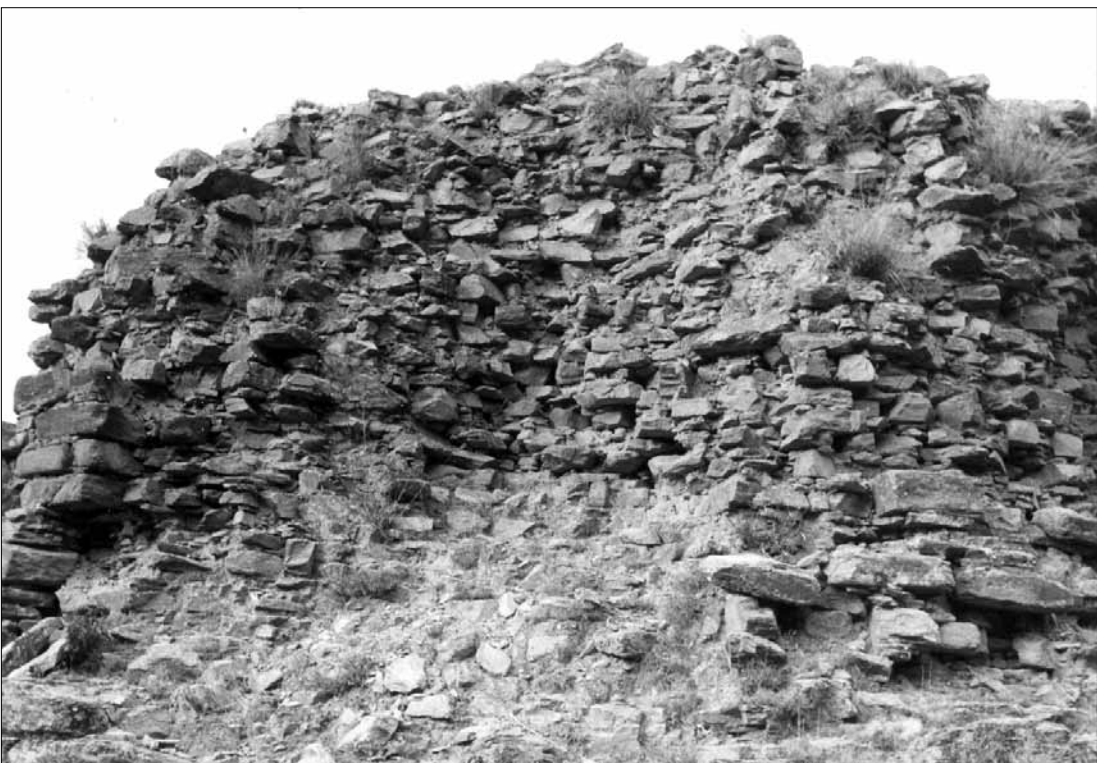

Fig. 34. Stupa of Jurjurai. S side; 3rd and 4th storey core. (Taddei 1958; Neg. CS).

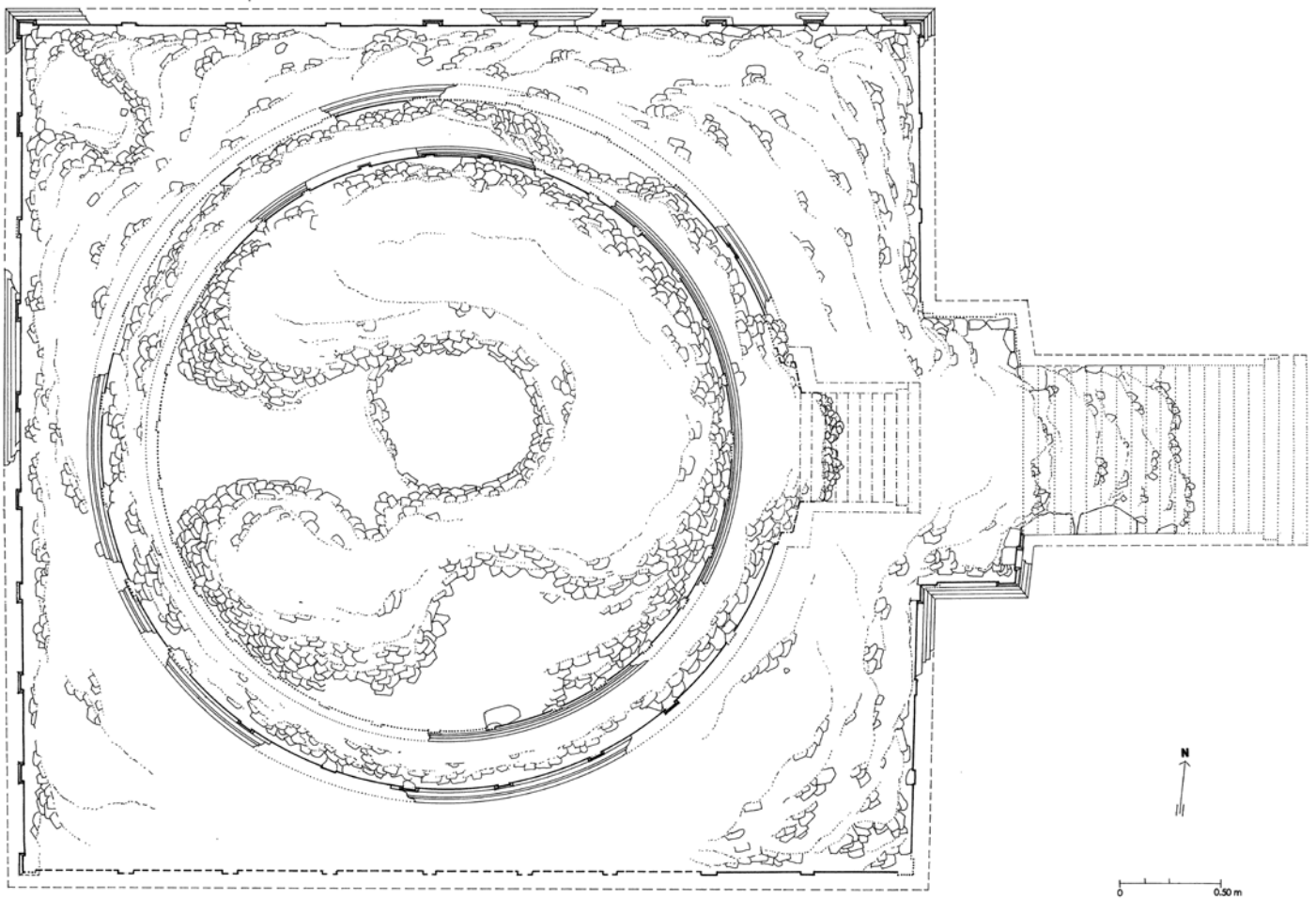

Fig. 35. Stupa of Jurjurai. Plan. (Sabelli 1993; Martore 2003).



Fig. 36. Stupa of Jurjurai. E-W cross section. (Sabelli 1993; Martore 2003).

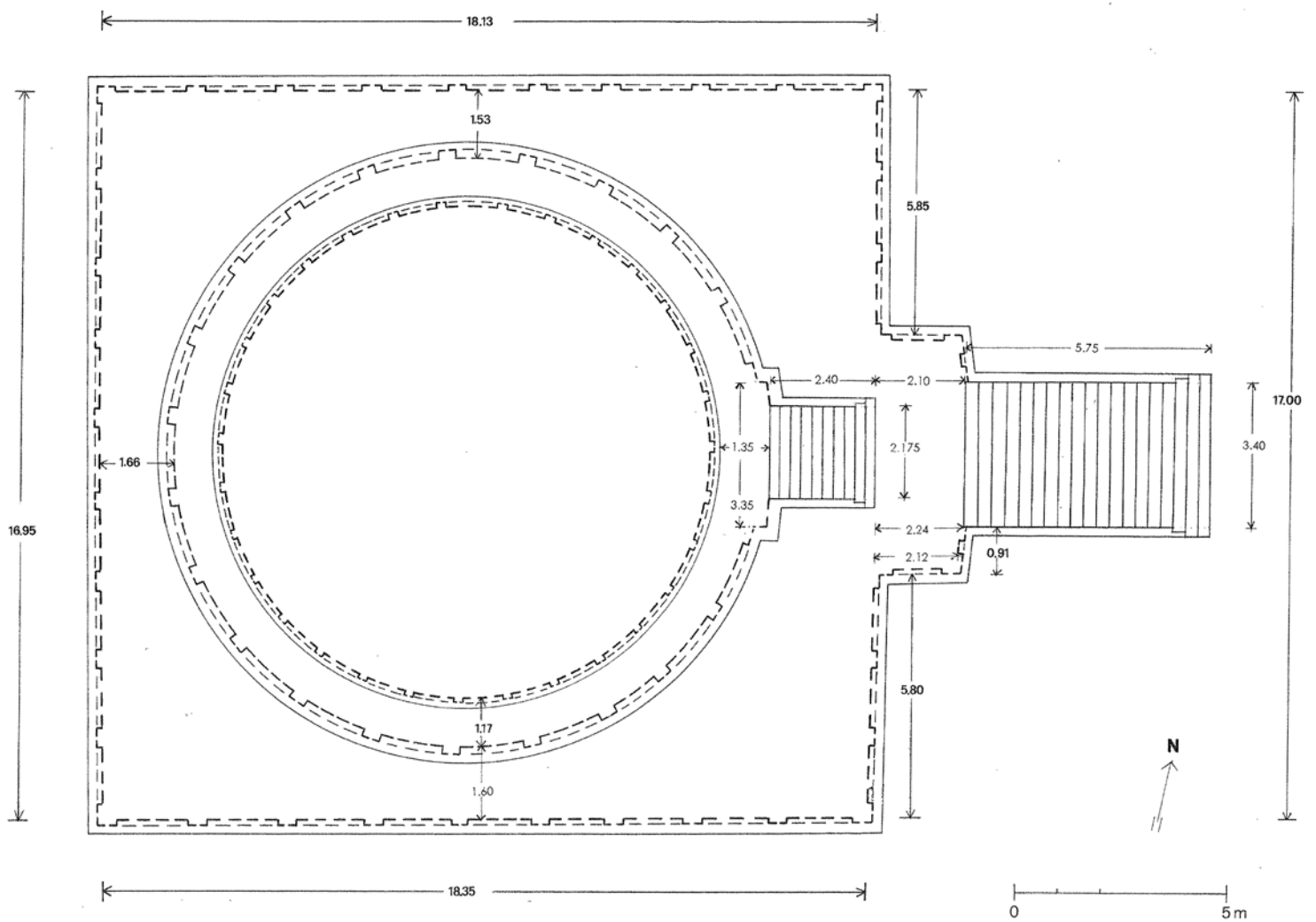

Fig. 37. Stupa of Jurjurai. Sketch plan showing the measures (scale 1:100). (Sabelli 1993; Martore 2003).

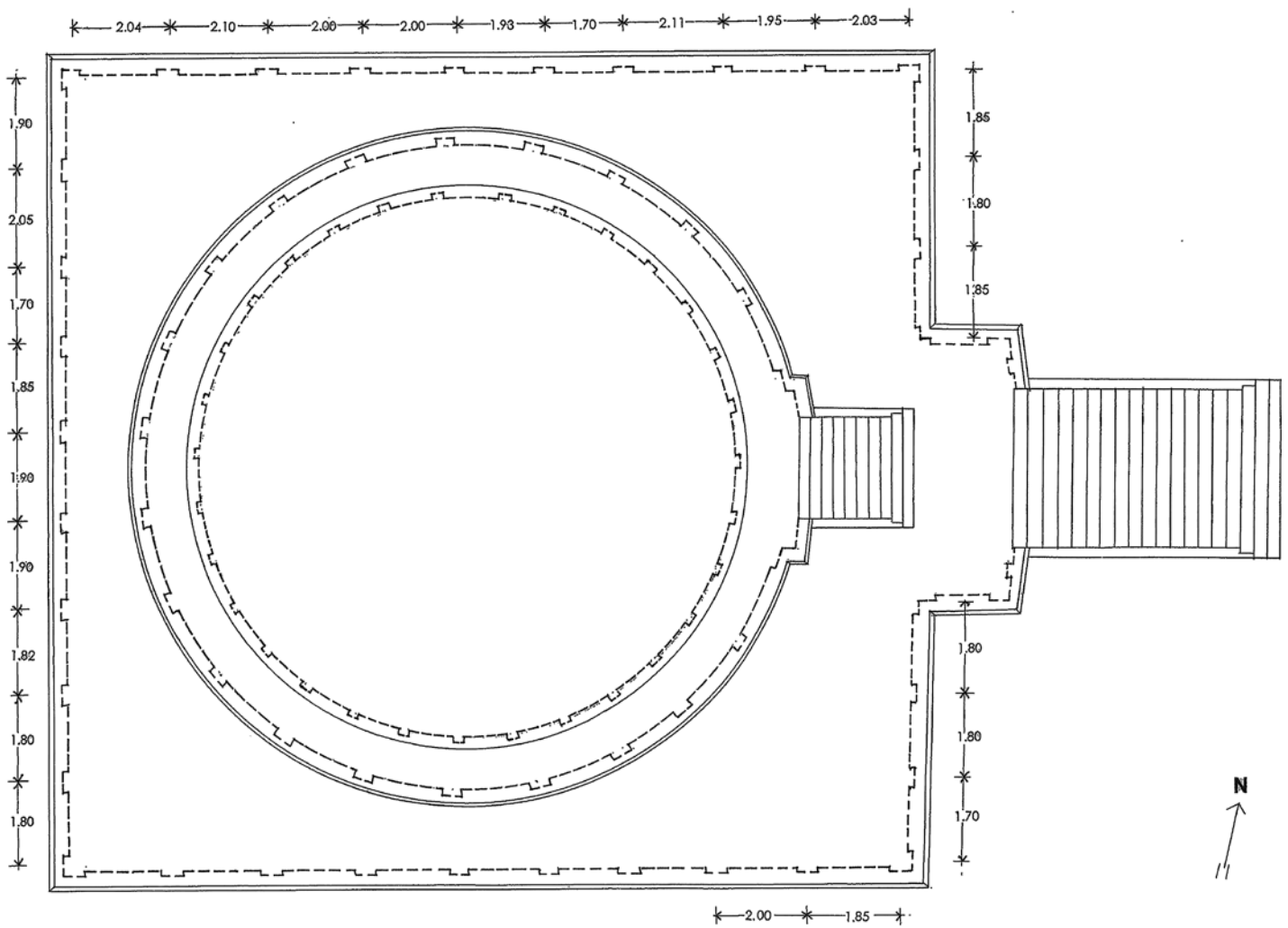

Fig. 38. Stupa of Jurjurai. Sketch plan showing the measures of the distances between the centrelines of the 1st storey's pilasters. (Martore 2003).

A. Stupas

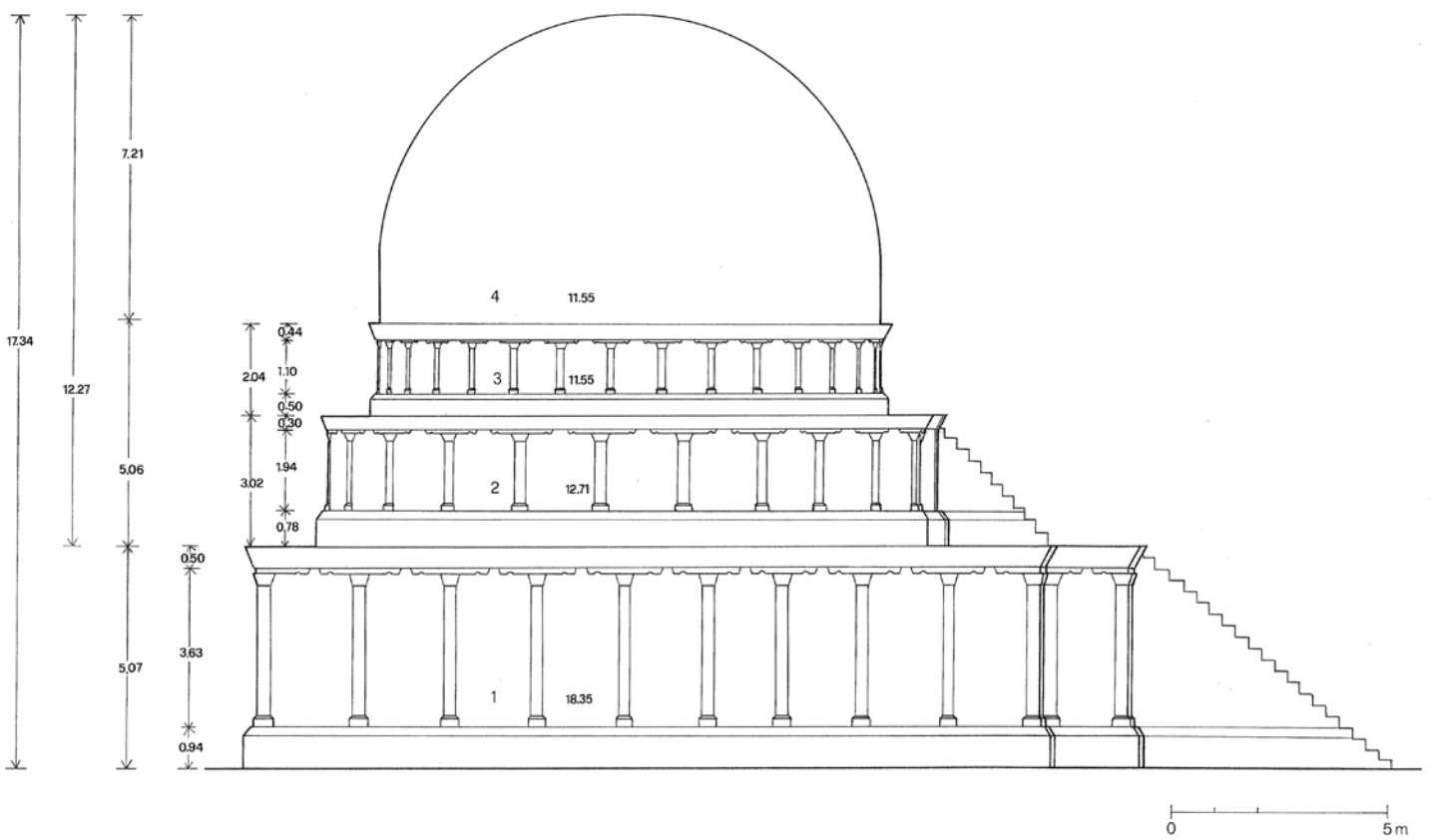

Fig. 39. Stupa of Jurjurai. Sketch elevation showing the measures. (Sabelli 1993; Martore 2003).

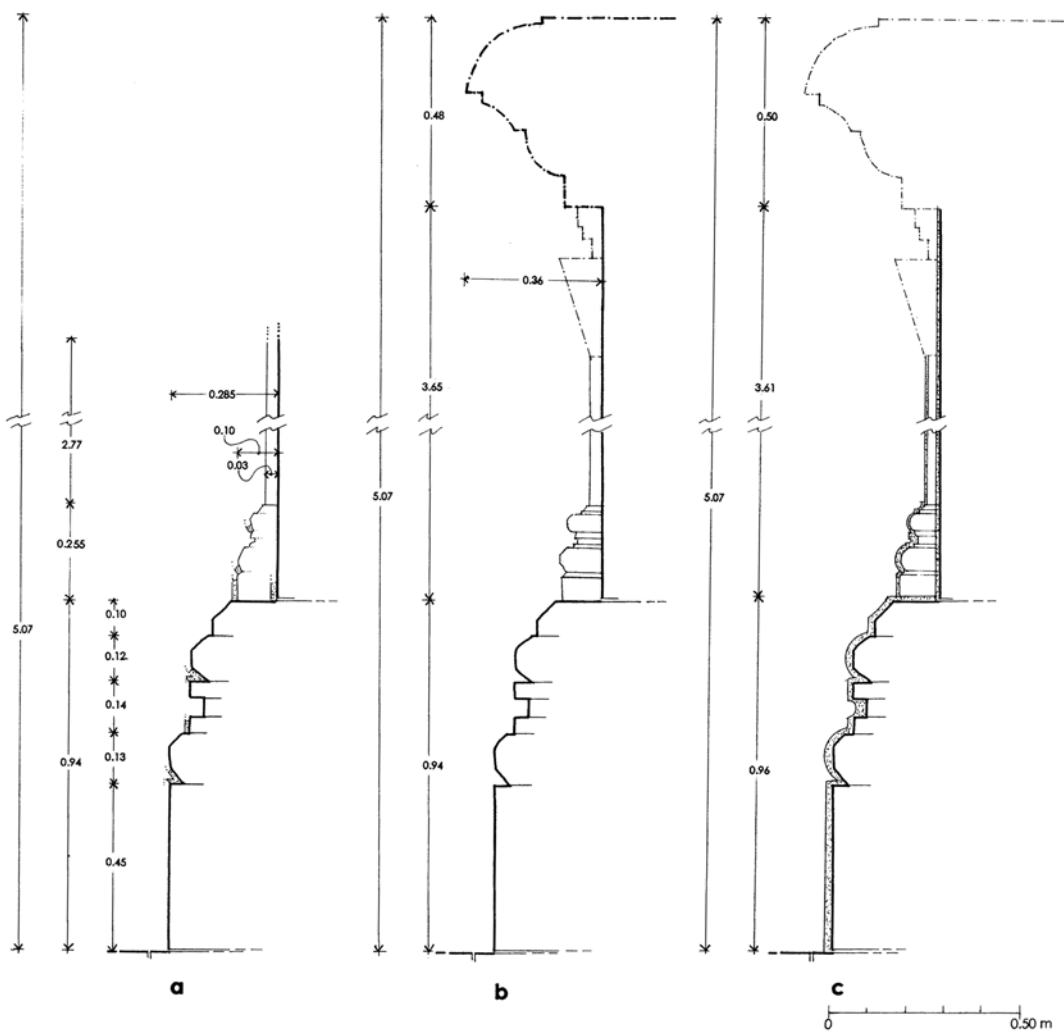

Fig. 40. Stupa of Jurjurai. 1st storey. *a.* profile. *b.* reconstructed profile, without plaster. *c.* reconstructed profile, with plaster. (Sabelli 1993; Martore 2003).

A. Stupas

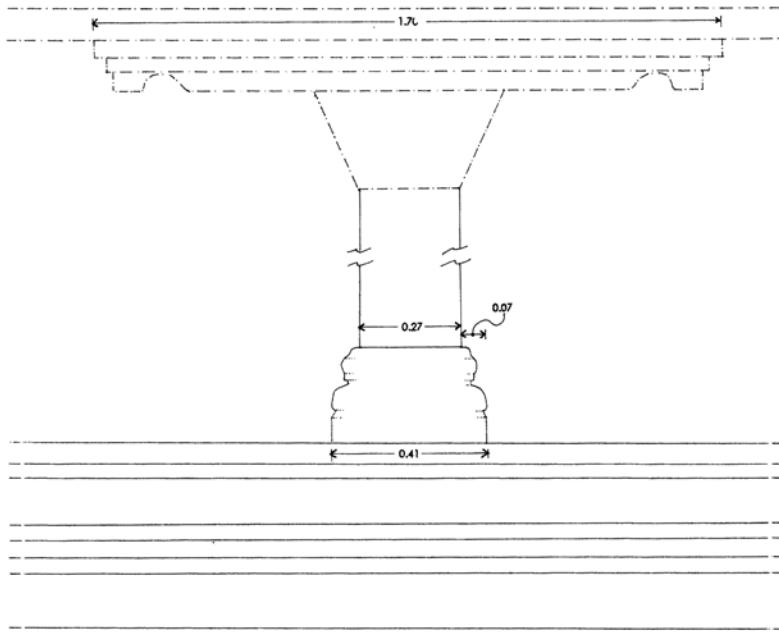
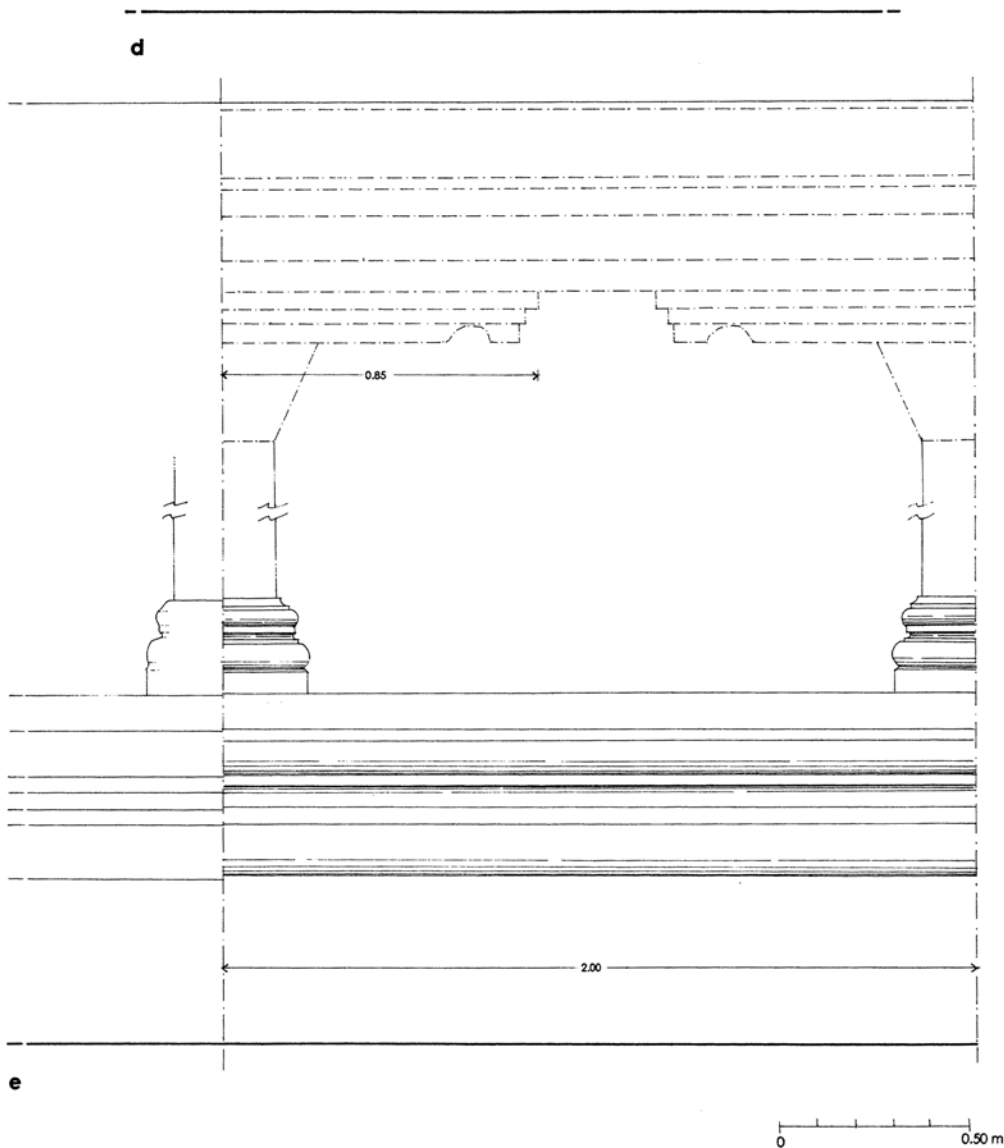

Fig. 41. Stupa of Jurjurai. 1st storey. *d.* elevation of the base, pilaster and cornice. *e.* elevation showing the centreline of the pilasters. (Sabelli 1993; Martore 2003).



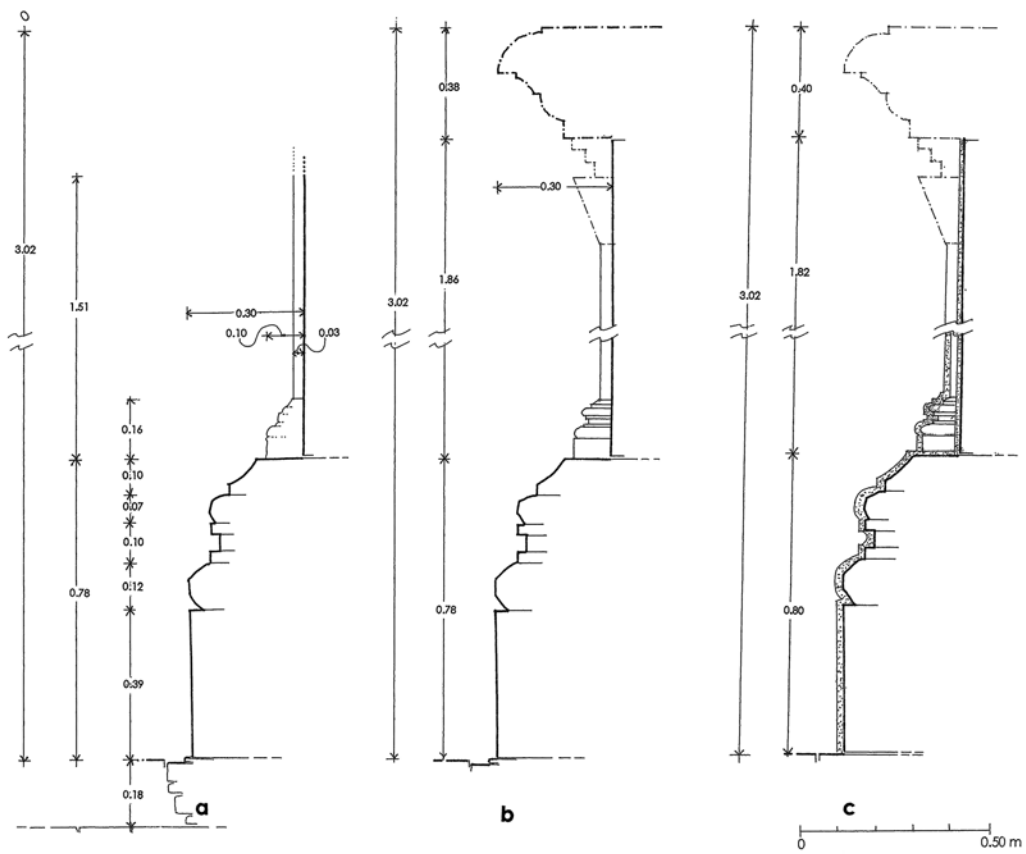

Fig. 42. Stupa of Jurjurai. 2nd storey. *a.* profile. *b.* reconstructed profile, without plaster. *c.* reconstructed profile, with plaster. (Sabelli 1993; Martore 2003).

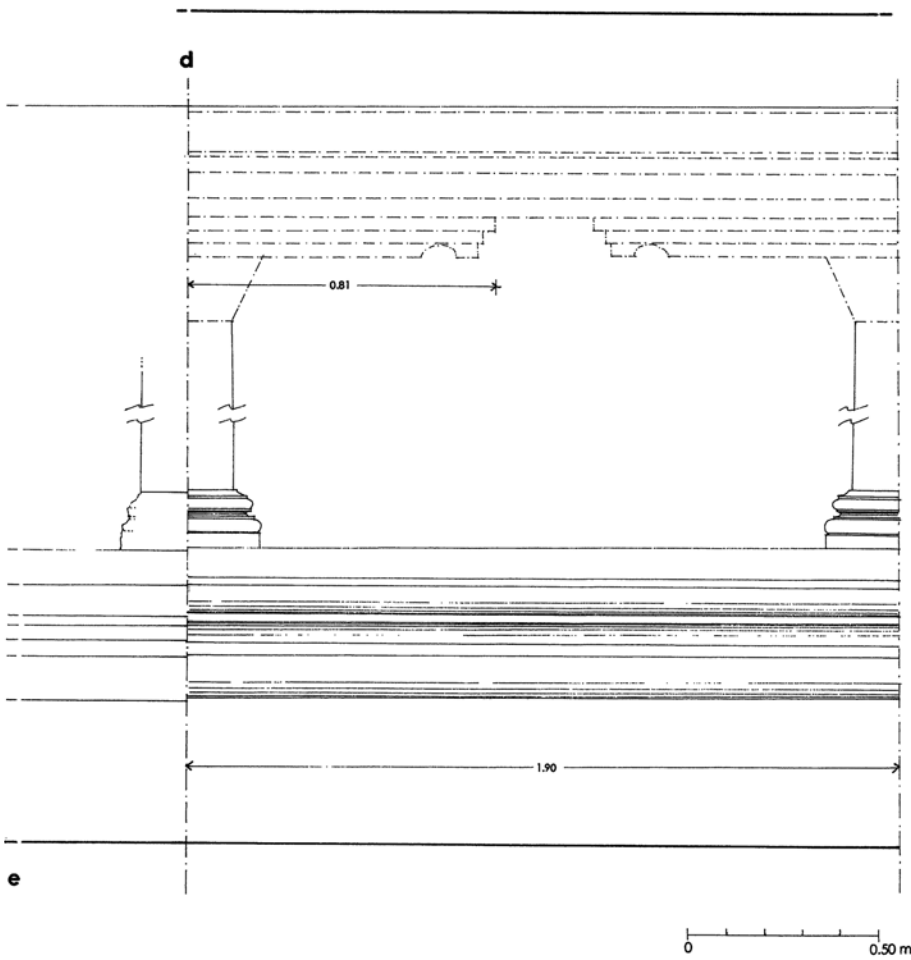
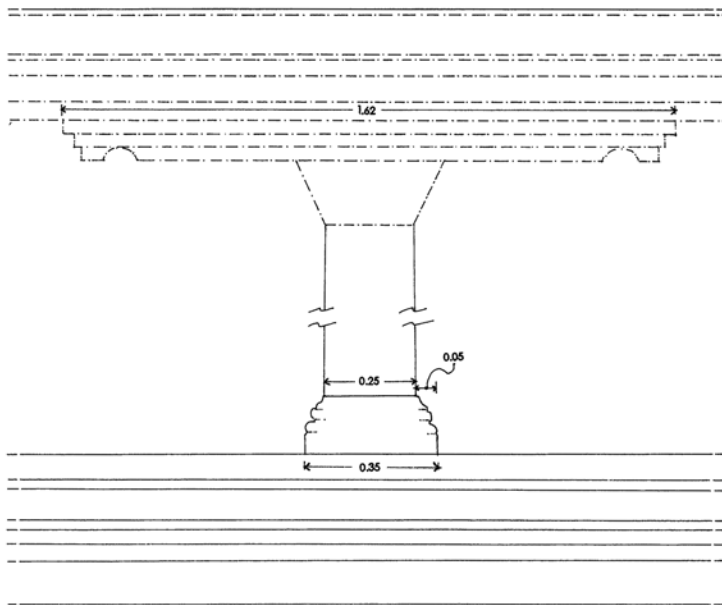

Fig. 43. Stupa of Jurjurai. 2nd storey. *d.* elevation of the base, pilaster and cornice. *e.* elevation showing the centreline of the pilasters. (Sabelli 1993; Martore 2003).

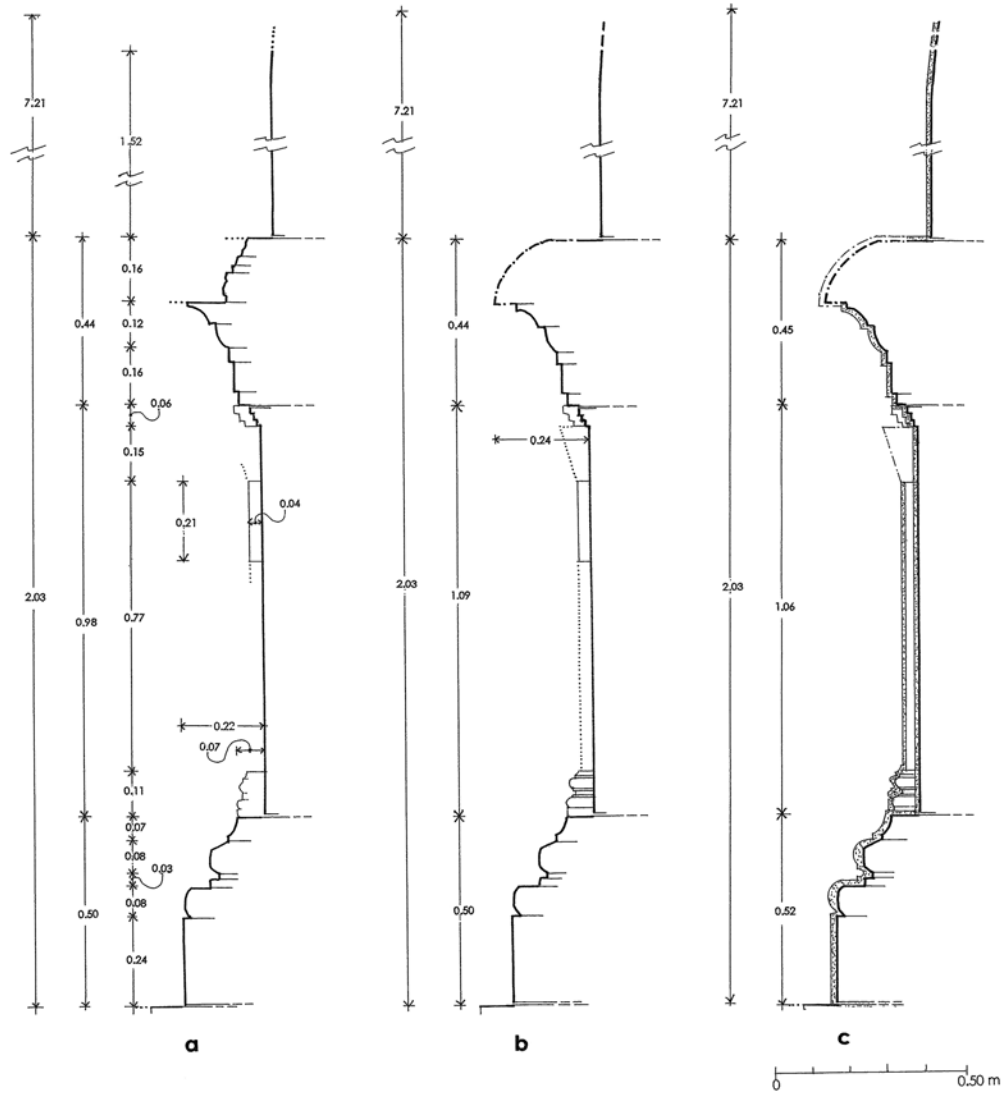
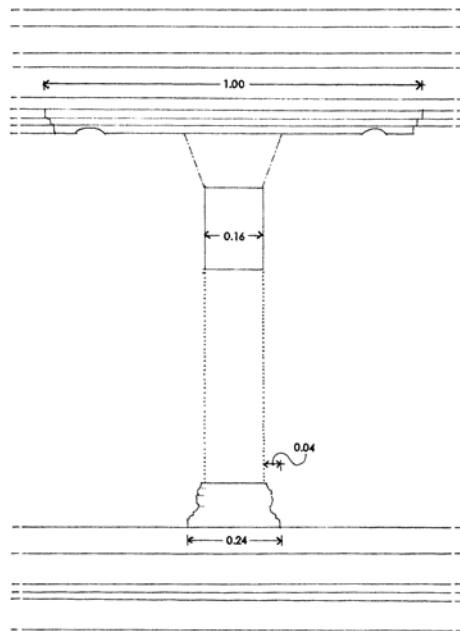
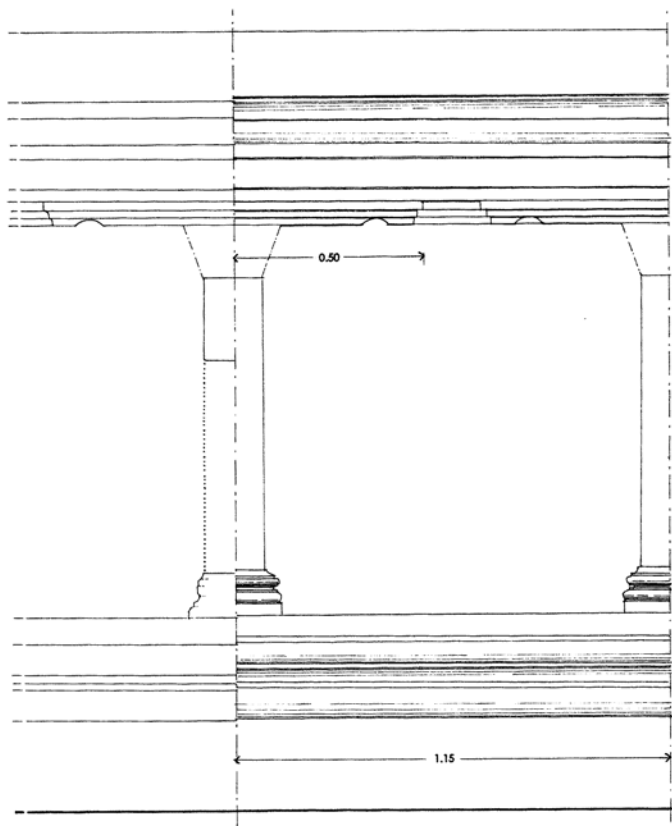

Fig. 44. Stupa of Jurjurai. 3rd, 4th storey. *a.* profile. *b.* reconstructed profile, without plaster. *c.* reconstructed profile, with plaster. (Sabelli 1993; Martore 2003).



d



e

0 0.50 m

Fig. 45. Stupa of Jurjurai. 3rd storey. *d.* elevation of the base, pilaster and cornice. *e.* elevation showing the centreline of the pilasters. (Sabelli 1993; Martore 2003).

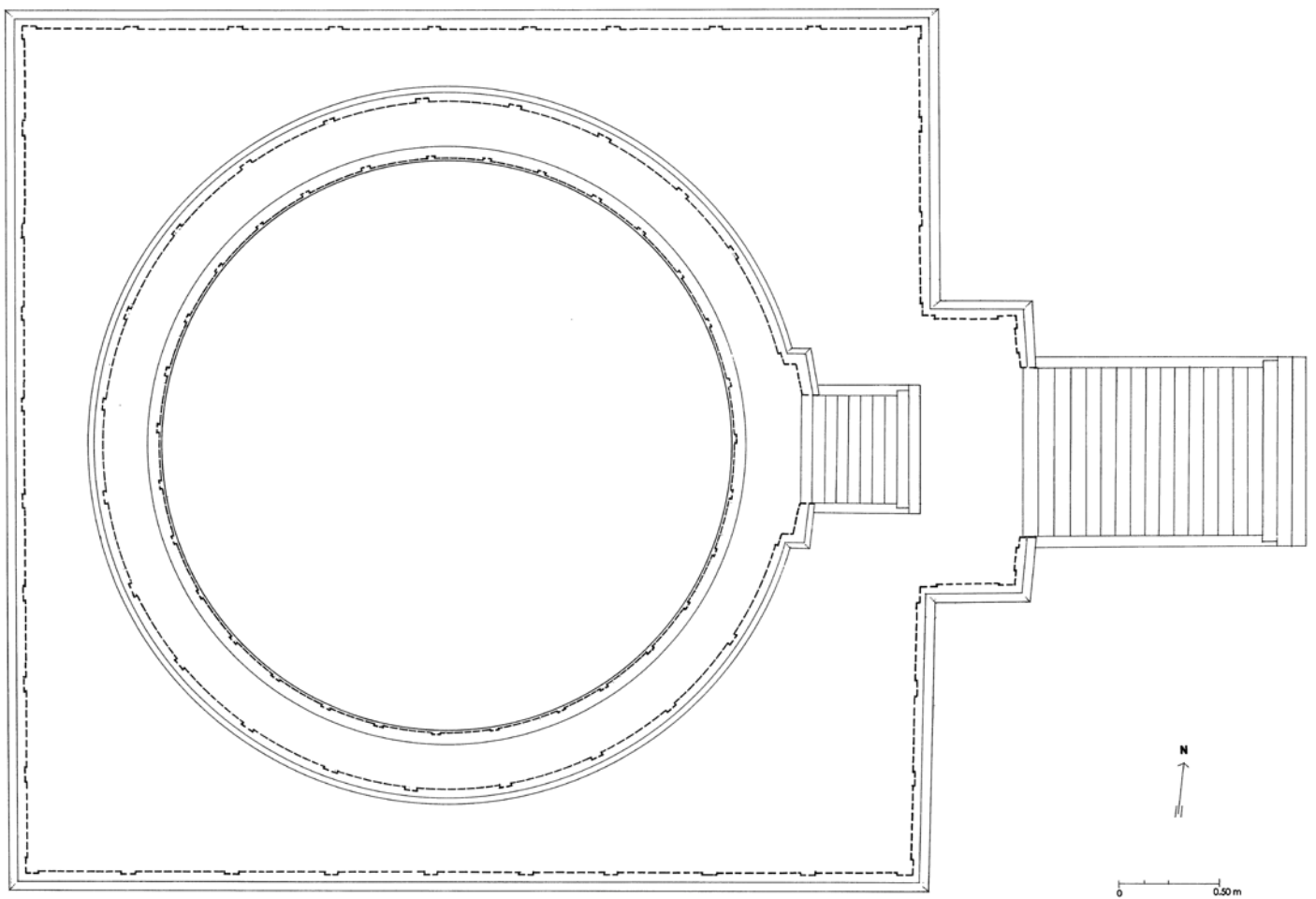

Fig. 46. Stupa of Jurjurai. Reconstructed plan. (Sabelli 1993; Martore 2003).

A. Stupas

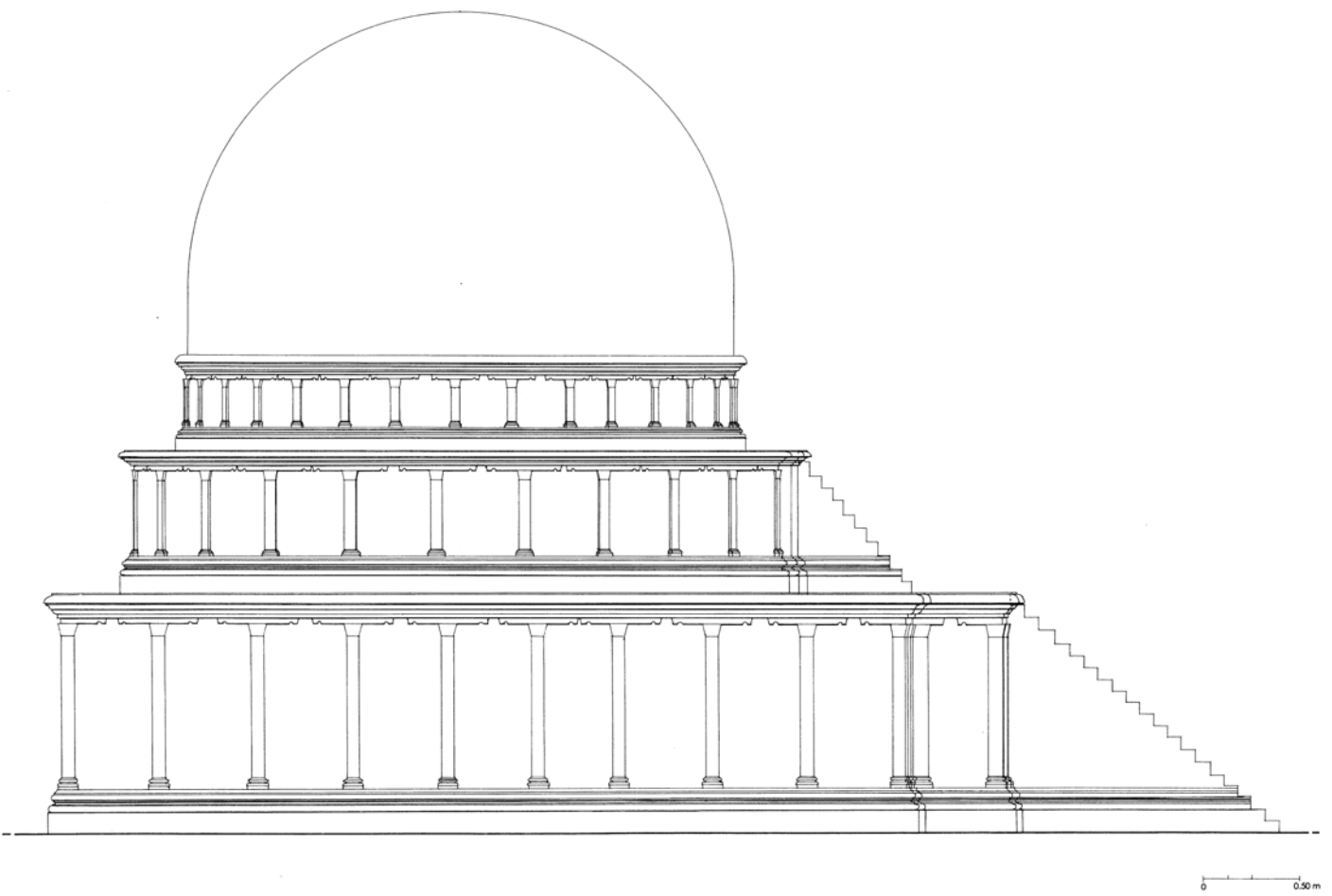

Fig. 47. Stupa of Jurjurai. Reconstructed elevation. (Sabelli 1993; Martore 2003).

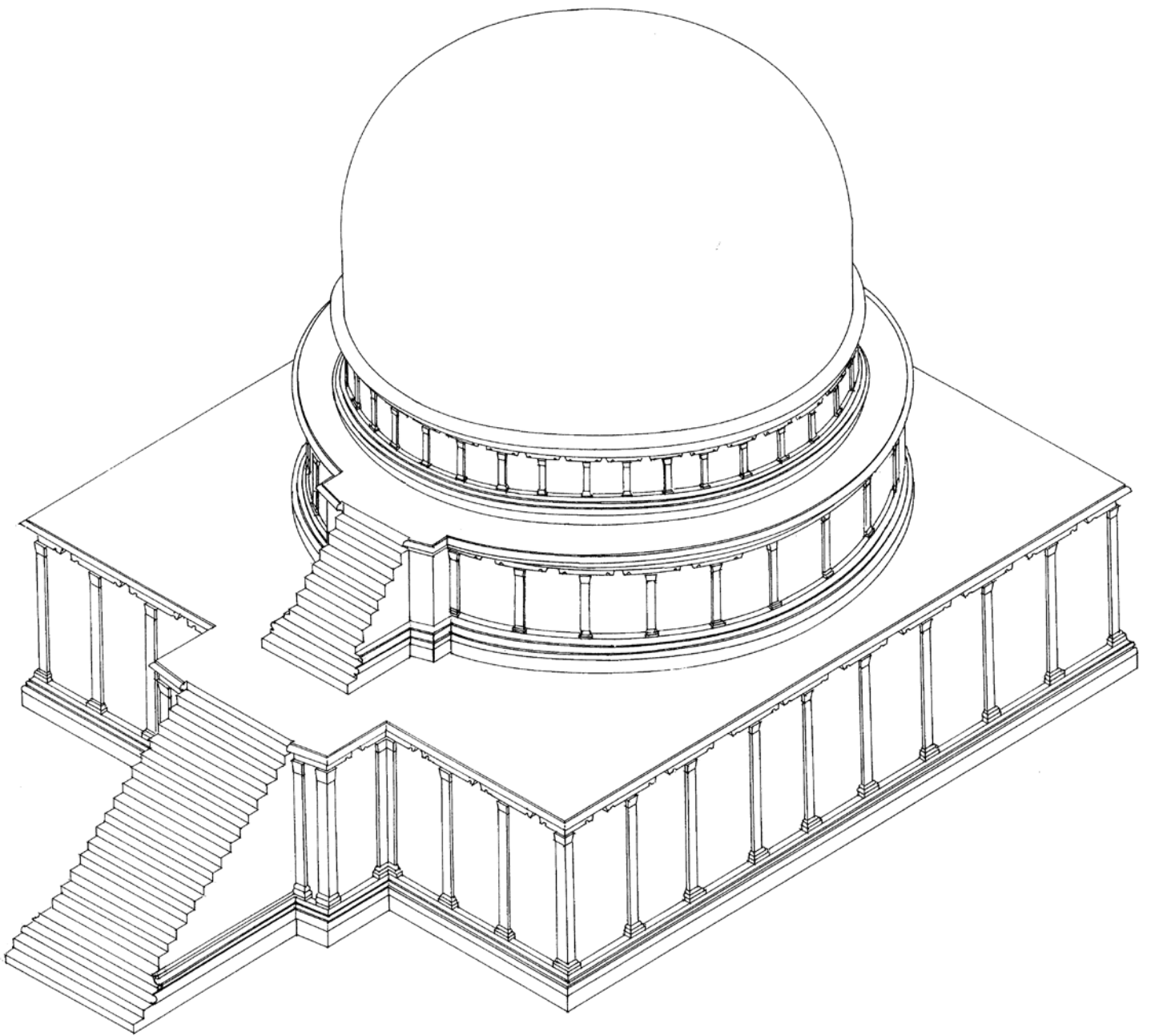

Fig. 48. Stupa of Jurjurai. Axonometric view. (Martore 2003).

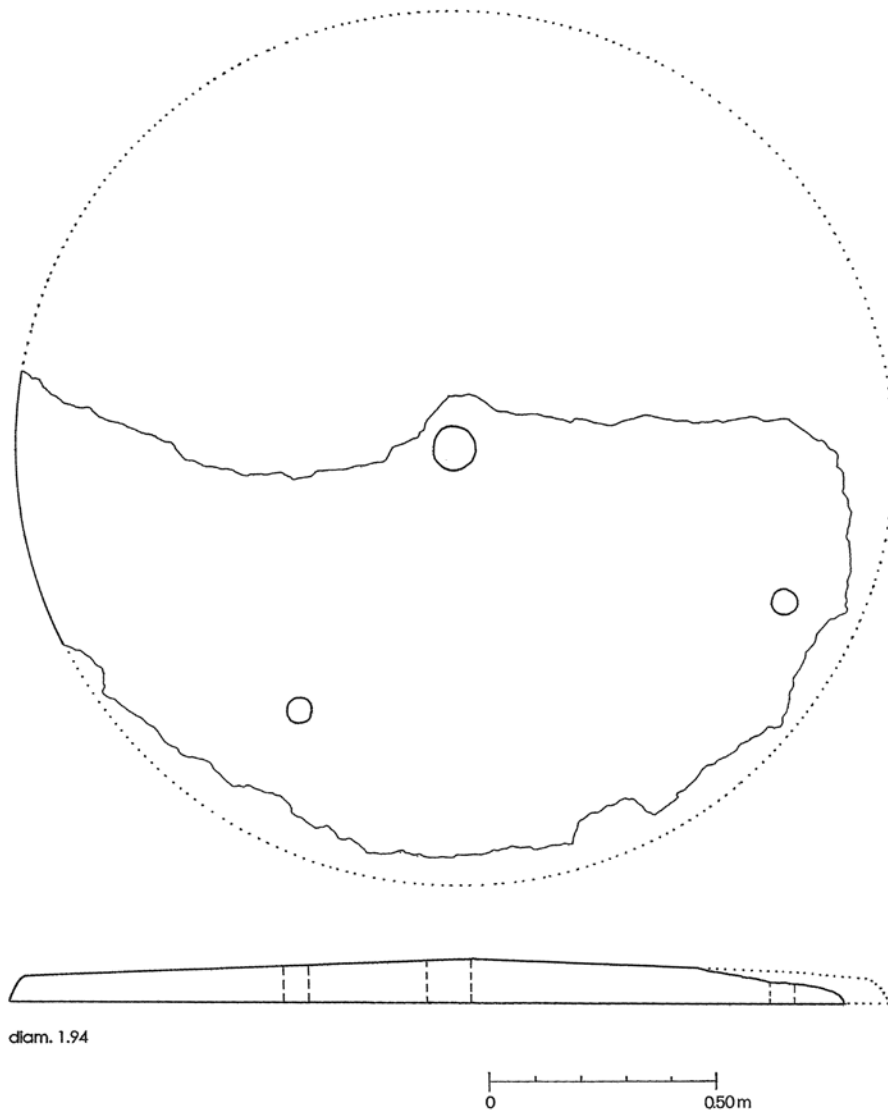

Fig. 49. Stupa of Jurjurai. Chattravali disk. (Sabelli 1993; Martore 2003).

A3. Stupa of Loebanr

(Figs. 50-77)

The Site

Zone of Jambil-Saidu. Jambil Valley.

Position: Lat. 34° 44' N; Long. 72° 24' E; SPM 43B/6.

Ascending the left bank of the Jambil Valley from Mingora one arrives at the sacred area near the village of the same name. It is situated on a rocky outcrop of the mountain rising behind it.

It takes in the area dominated by the stupa and a terrace above, which belongs to the monastery. The zone is largely covered by tilled fields, a few scattered modern buildings (including a tobacco leaf drying building). On the W side and running N-S a tall long substruction wall is visible. Further up the hill there is a spring.

The great stupa, rectangular in plan, runs round the stairway, situated on the E side, towards the cliff face that slopes down towards the bottom of the narrow valley through which a stream runs; in front of it rises the cliff face from which numerous boulders project. It is in a highly deteriorated state owing to the theft of materials used for new building work and to unauthorized excavations, which underwent an acceleration after 1964. In 1991 it was observed that a shaft was being dug on the S side, proceeding vertically from above and reaching down as far as the platforms and probably beyond. In 2005 the complete destruction of the stupa occurred, which was razed to ground level. Therefore all the present documentation refers to the year the graphic survey was conducted (Sabelli 1993).

Bibliography and Documentation

Stein 1930: 46 ⁽¹⁾.

Tucci 1958: 310 ⁽²⁾.

Faccenna 1964: 25 (only mentioned); 1980-1981: 755, n. 2.

In 1979-1981 Dr Abdur Rahman (Department of Archaeology, University of Peshawar) performed a sondage in the corner above the rectangular storey near the stairway which revealed several stupas but without any other result and then filling in the excavation; no other documentation exists (kind verbal communication).

Taddei 1958, 1959: photographic reconnaissance.

Faccenna 1958; photographic reconnaissance.

Faccenna 1961: description and graphic survey by V. Caroli.

Gui and Cimmino 1964-1965: graphic survey and photographic documentation.

Olivieri 1989, 1991, 1993: reconnaissance with description and photographic documentation photographic documentation.

Nascari 1992-1993: reconnaissance.

Khan Ashraf 1993: 36, pl. IV, fig. 21.

Kuwayama 1993: photographic documentation.

Sabelli 1993: graphic survey.

Martore 2003: verification of measures, corrections, updating of graphics and symbols.

Spagnesi and Olivieri 2005: photographic documentation.

The Stupa

The stupa stands on a double platform and consists of a 1st storey, quadrangular in plan, and two progressively receding circular storeys, the second of which forms the drum, decorated with pilasters, from which the core corresponding to the probable raised dome begins. The stairway is aligned on an E axis, provided with a projection, on the 1st and 2nd storeys; the steps must have been related to the double platform.

Only a few traces of the monumental walls still remain of the first three storeys, while the platform to the W and S is filled in with debris and not visible. A shaft has been dug through the centre of the core; the shaft is open on the S side and descends from the top as far as the base of the 1st storey and beyond.

The facing of the stupa is made using a block and small slab technique. The

⁽¹⁾ 'Skirting the hillside for about a mile south-eastwards to L_e-bānde, I observed a badly destroyed Stūpa in a gully above the hamlet. The size of the mound resembled that of the Sharārai Stūpa V'.

⁽²⁾ 'The most impressive ruins of stūpas being in Loe ban [...]. The stūpa of Loe ban has been described by Stein; it is built with huge stones'.

large-sized parallelepiped shaped blocks of fine-grained gneiss and layered gneiss are larger (h. 0.35, leng. 1.46) in the square storey, and smaller (h. 0.23, leng. 0.15-0.18) in the upper circular storeys; they are arranged in regular horizontal rows, closed at the sides by overlapping small slabs and separated by two/three rows of small slabs.

The core consists of rough hewn parallelepiped shaped blocks, slabs and stone waste laid rather carelessly and held together by clay.

Double Platform; Stairway

The lower platform, of indeterminable height (only partially visible), is closed off on top by a projecting reverse cavetto cornice; the cornice would have continued upward (reconstructed as a short wall?) as far as the upper platform. The latter, set back, has a base with plinth, carinated two-slab torus and gradually receding three-slab cavetto; the probable cornice is unknown. On the front, the platforms must have had stairways; a sondage dug on the E side revealed the core of a probable stairway. In view of the height of the upper platform it is possible to estimate the number of steps (five) from the most common type of riser and tread (riser 0.23 and tread 0.30), with an inclination of 38°; these measures are repeated also for the lower platform (three visible steps with an inclination of 41°).

On the N side a wall broken off at both ends abuts the lower platform; the height, length and function of this wall are not known; it was probably a substruction wall, like the other two above it, the purpose of which was to offset the difference in ground level and to obtain the level surface required to build the monument.

1st Storey, Quadrangular in Plan; Stairway

The 1st storey, quadrangular in plan, is set back by 1.30; h. 4.10, width S 16.95, N 16.87, W 16.00, E 15.74.

It has a wall divided up by pilasters (h. 2.94). The storey has a scotia type base with plinth made of rows of blocks and small slabs, upper and lower three-sided beveled torus made of three slabs, a flat scotia (with vertical profile) between two slabs, cavetto made by four shaped slabs. Above the cavetto, it is closed off by a receding fillet and by another projecting one, on which the pilaster is supported.

The pilaster has a scotia and shaft type base; the capital with its modillion and cornice has not been conserved. Noteworthy is the structure of the shaft of the pilaster obtained from the blocks morticed with the wall alternately to the right and left, separated by one/two non continuous rows of small slabs. Workmanship excellent.

The S section of the E front wall and the corner of the stairway projection of the

inner pilaster have been conserved; the probable outer pilaster is missing. There are three pilasters on the right and left of the stairway, including the inner corner one of the stairway projection with an interaxis of 2.45. For the remaining N, S and W sides, 10 pilasters have been estimated, including the corner ones computing an interaxis as a function of the side length: N and S sides, 1.88, W side, 1.75.

The stairway has been reconstructed with 15 steps with a riser of 0.24 and a tread of 0.30 and an inclination of 39°.

Cell

Under the ramp of the stairway on the S side near the projection a small rectangular space has been obtained (width 1.25, depth 1.40). The two door jambs have not been conserved, and there is a large gap corresponding to the position of the left jamb; the door opening is a single arch for the full length of the opening. On the other hand, the internal part of the cell (h. 1.15) has been conserved, together with the springer of the dome vault. In the left rear corner of the cell, a projecting straight slab is situated at the top of the walls, together with an adjacent one laid across the corner, forming a support for the dome, to which two blocks laid on top seem to belong. It is not possible to determine the solution used in the front part of the cell (see Tokar Dara no. A11). The reconstructed height of the vault may be as much as 1.80. As far as the floor is concerned, a short section of the underlying stone and slab work remains.

2nd Storey, Circular in Plan; Stairway

Set back by 1.75 on the N and S side, to the W by 1.35, 2.85 high with a diam. of 12.75. A lower section of the wall has been conserved together with the N and S sides of the stairway. The base (h. 0.545) repeats the profile of the preceding one in the lower storey, with a plinth made of dressed blocks and slabs, scotia and cavetto made of schist blocks; on top of this lie the receding fillet and the projecting one, on which the pilasters are laid.

The wall, set back, is composed of dressed gneiss blocks and schist slabs on the sides of the latter with one/two rows of schist slabs between overlapping blocks; here and there a slab is missing. It is interesting to note this texture of very closely packed blocks as well as the use of the two stone types: gneiss for the blocks, dark coloured schist for the slabs.

The wall has a background of pilaster decoration with scotia type base and shaft obtained from the alternating tall and short blocks, the taller ones extending into the wall on the right and the left, often attaining a length of up to 0.80. The lower width of the base measures 0.41, and the shaft 0.25. The interaxis between them is 1.45.

In the inner corner and outer corner of the projection of the wall meeting the stairway there is a double angular pilaster. This is followed by a surviving section of the ramp wall, along which the base moulding continues, taking in also the two fillets supporting the pilasters, which are obviously missing. The wall is smooth and set slightly back (0.03).

The stairway may be reconstructed with 8 steps with a riser of 0.31 and a tread of 0.30 and an inclination of 47°.

Extensive traces of very thick plaster work remain: 0.02 on the shaft, thicker in the base toruses.

Residual paving is visible around the base plinth in the ramp projection section, on the S side, which is composed of small more or less rectangular slabs, sometimes fragmented.

The cornice is missing; it was already missing in 1961.

3rd Storey, Circular in Plan (Drum); 4th Storey, Raised Dome

Only the core remains, now severely reduced in width and height compared with the 1958 and 1959 photographic reconnaissances and the 1961 and 1964 surveys. On the strength of this documentation and notes (Faccenna) dating to 1961 we can recover and reconstruct the upper parts of the monument as far as is possible. The old data have been inserted in the new graphs.

In 1964 the 3rd storey and the beginning of the 4th storey still existed.

The 3rd storey, set back with respect to the 2nd by 1.10, h. 1.89, with a diam. of 10.50, had a base, wall with pilaster decoration and part of the cornice. It had a scotia type base lacking the two upper fillets and retained a small plaster residue; the pilasters had a scotia type base, shaft, capital with modillion, and an interaxis of 1.28; the cornice, above the architrave strip, was moulded with fillet, ovolo and cavetto, and ended in a reverse projecting cavetto.

The raised dome has been conserved for a very short stretch in length and elevation (max. h. 1.60) with a slight curvature; its springer is aligned with the wall of the storey below.

Internal Structure

In the years 1961 (Faccenna reconnaissance) and 1964 (Gui and Cimmino surveys) a horizontal tunnel opened in the core at the base of the 2nd storey (h. c. 2.00; leng. c. 8.00) on the E side (E-W section) of the stupa. It stretched as far as, and beyond, a cavity left by the removal of the material composing a small stupa which previously stood here and of which traces of the surfaces of the core enclosing it remain. Two sections of its dome and, below, sections of the square

story, with parts of its core, are visible. The latter enclosed the lower part as far as the springer and the bearing surface, rendering it invisible; this would have revealed the time of its construction, which in all likelihood may be considered contemporary with the larger stupa in view of the height at which it was situated. No other indications are visible concerning the possible subdivisions of the cylindrical storey. The stupa was slightly offset towards the N and E ⁽³⁾. It bears an extraordinary resemblance to the small stupa inside the large Stupa of Kunala, at Taxila, which was also offset (Marshall 1951: 350-51, pl. 87a ⁽⁴⁾; Errington 1999-2000). Stupas later incorporated in the construction of new monuments are more frequent (Errington 1999-2000).

Measures of the small earlier stupa:

Square storey: 2.20 side leng.; max. visible h. 0.90. Cylindrical storey and dome: h. 1.78; diam. 1.70; set back with respect to the square storey by 0.25; total maximum conserved height 2.68.

Between 1964 and 1993 (Sabelli) further illegal excavation work was performed in a shaft descending from the dome as far as the base of the stupa itself. It avoided contact with both the previous tunnel and the small inner stupa.

For the sake of documentary completeness mention must be made of several chattravali elements lying a short distance away from the stupa, although they are not declared to belong to it:

no. 1: gneiss disk; diam. 1.29, thickn. 0.09; reverse ovolo edge profile;

no. 2: gneiss disk; diam. 1.04, thickn. 0.14; in a single slab, with joint element, with fillet profile and oblique cut;

no. 3: gneiss disk; diam. 0.97, thickn. 0.15; edge with vertical profile.

Reconstruction

The examination of the individual storeys yielded elements of use in reconstructing the monument which is given in the tables and plan view, elevation and axometry. It is very similar to the Stupa of Jurjurai (see no. A2).

The stupa stands on a double platform which, with the probable help of other structures, was able to offset differences in ground level. It has three gradually receding storeys, on the last of which (the drum) the raised dome stands, with the same diameter. The presence of the latter is demonstrated by the short section that

⁽³⁾ Nothing is visible now, (most) lost, as revealed by a comparison with Gui's cross section, which is shown here as it was executed in order to illustrate the comparison. Also conserved are the 3rd and 4th storeys; on the other hand, the stairway of the 2nd body is not given as it was probably covered at the time.

⁽⁴⁾ Marshall believes it to be earlier (Saka-Parthian), built on rock (tot. h. 9 ft. 8 in.; 1st storey with a square plan 4 ft. 6 in.; circular storey 2 ft 2 in.; dome 3 ft.; lacking plaster and umbrellas).

has been conserved, as well as by the lack of coping slab on the drum cornice. The curvature can only be guessed at by comparison with similar profiles.

The 1st storey, rectangular in plan, and the two gradually receding circular storeys above have a scotia type base and architraved cornice with an ovolo and cavetto profile and are decorated with pilasters. The outline of the 3rd storey is complete; it is repeated, partially conserved, in the two lower storeys. The pilaster has a scotia type base, shaft, capital and modillion supporting the architraved cornice, with ovolo and cavetto style profile.

The two lower storeys are provided with a stairway with projection, resulting in an interesting pattern of pilasters in the corners of the storeys and their projections in both the inner and outer corners.

Aligned on the E side there are stairways also in the double platform in a gradually narrowing rising succession with an inclination of between 41° and 47°.

Differences may be observed in the projection of the stairway ramps.

Moreover peculiar structures are displayed by the Stupa of Loebanr, for instance, a cell built on the S side of the 1st storey stairway ramp, in the section near the projection, and a small stupa incorporated in the core of the 2nd storey.

Both display aspects and allow considerations concerning their presence and functions. Other similar examples are known.

Consideration should be given to the relations between the storeys as regards both their two component parts and between themselves. The result is an overall impression of solidity due to the reduced number of storeys (three) that are gradually set back, which is enhanced by the presence of the platforms and embellished by the pilasters; an important role is played by the stairways aligned in a continuous axis with decreasing width from the platforms and in the stupa storeys in an upward direction, which elicit an effect of elevation and spirituality. It is probably no coincidence that the small inner stupa is located on the same axis, thus acquiring a peculiar significance with reference to the sacred nature of the entire area.

What is lacking for a complete understanding is of course a knowledge of the complex.



Fig. 50.
Stupa of
Loebanr. N-S
substruction
wall of the
Monastery on
the W side
of the Stupa.
(Nascari 1991;
Neg. CS).



Fig. 51. Stupa
of Loebanr. N
side; double
platform,
lower and
upper; on
bottom right,
stretch of the
substruction
wall.
(Kuwayama
1993).

A. Stupas



Fig. 52. Stupa of Loebanr. 1st storey, S side. A stretch of the storey, projection with inner corner pilasters, stairway, cell; at the top, stretch of the stairway of the 2nd storey. (Nascari 1993; Neg. CS).



Fig. 53. Stupa of Loebanr. 1st storey, S side of the stairway; the cell with angular elements of the springer of the dome. (Kuwayama 1993).



Fig. 54. Stupa of Loebanr. 2nd storey, S side, with a stretch of the storey, stairway projection and side of the ramp of the stairway; view from E. (Nascari 1993; Neg. CS).



Fig. 55. Stupa of Loebanr. 2nd storey, S side, with a stretch of the storey and floor, stairway projection and side of the ramp of the stairway; view from E. (Nascari 1993; Neg. CS).

A. Stupas



Fig. 56. Stupa of Loebanr. 2nd storey, S side, with a stretch of the storey and floor; view from E. (Nascari 1991; Neg. CS).

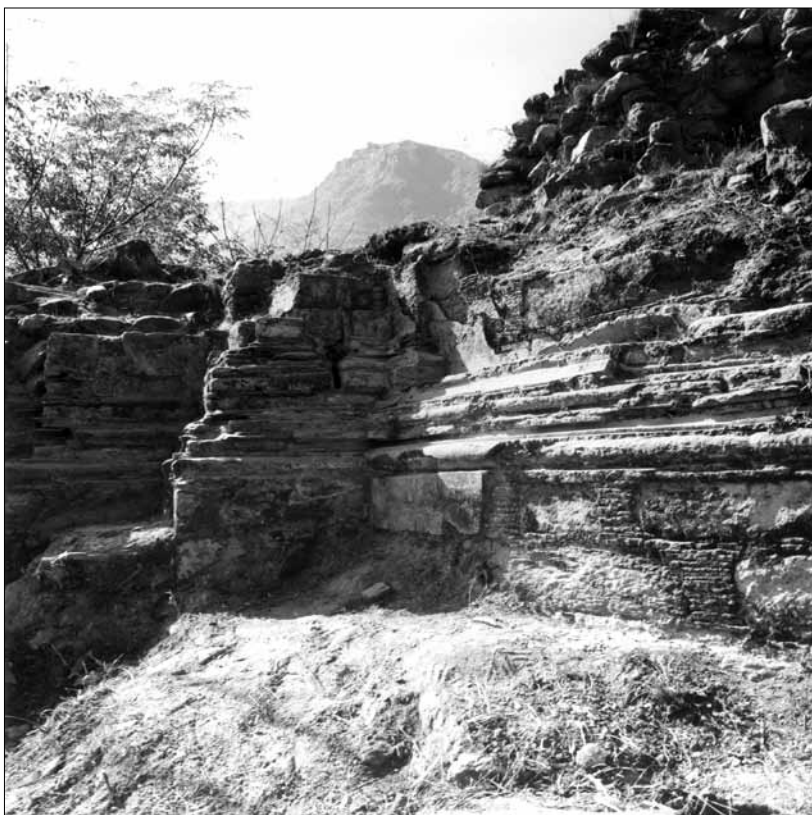

Fig. 57. Stupa of Loebanr. 2nd storey, N side, with a stretch of the storey, projection and side of the ramp of the stairway; view from N. (Kuwayama 1993).



Fig. 58. Stupa of Loebanr.
Chattravali disks, nos. 1, 2, 3.
(Nascari 1993; Neg. CS).

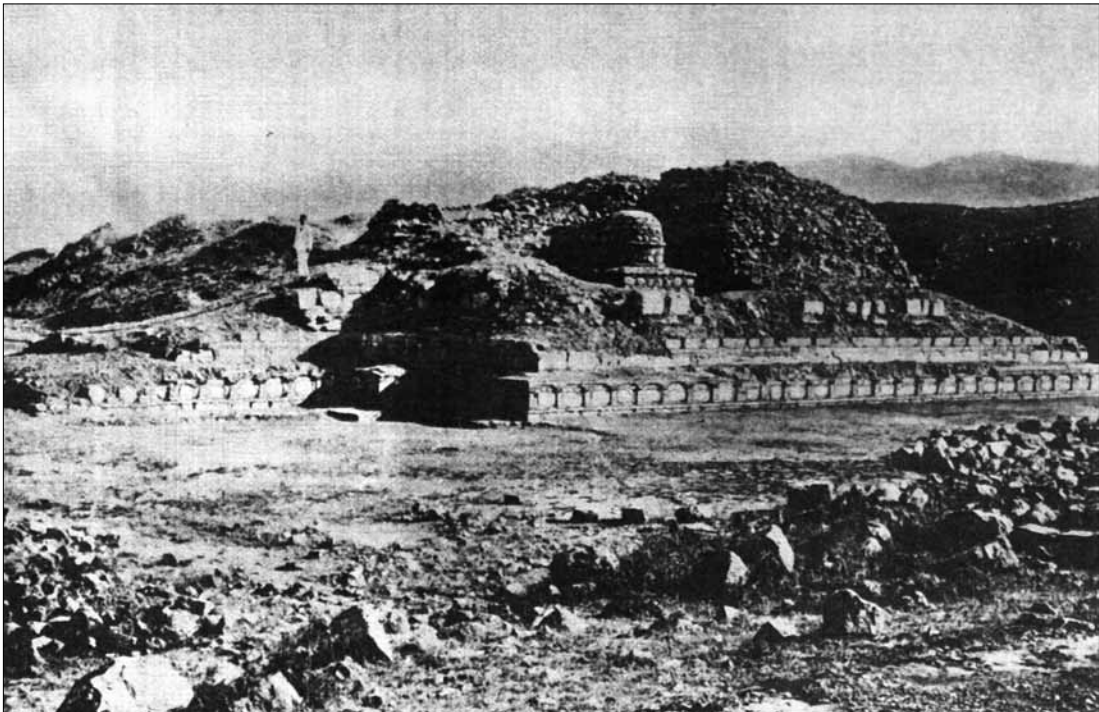

Fig. 59. Stupa of Kunala (Taxila). (After Marshall 1951: pl. 87).

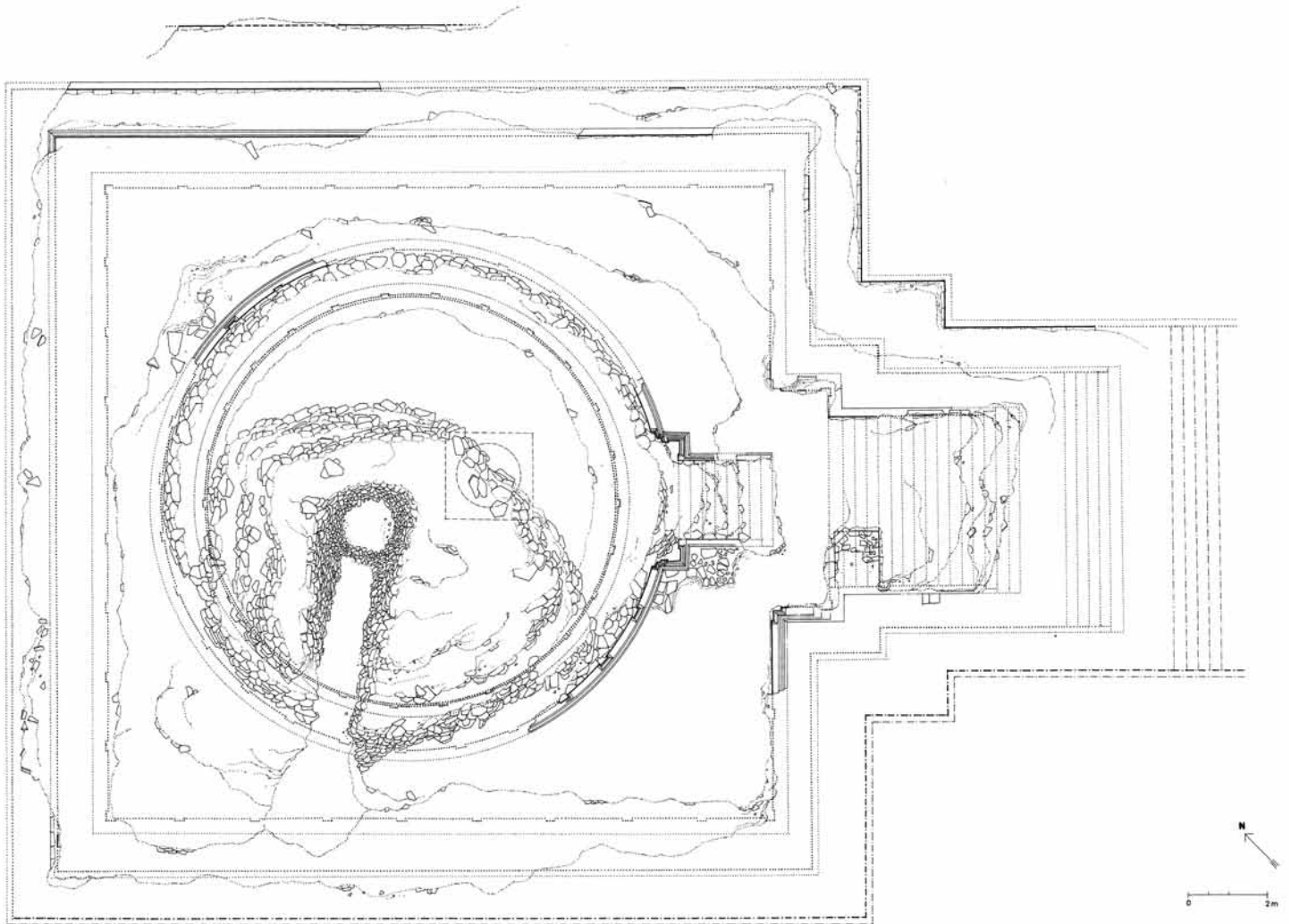

Fig. 60. Stupa of Loebanr. Plan. (Sabelli 1993, 1996; Martore 2003).

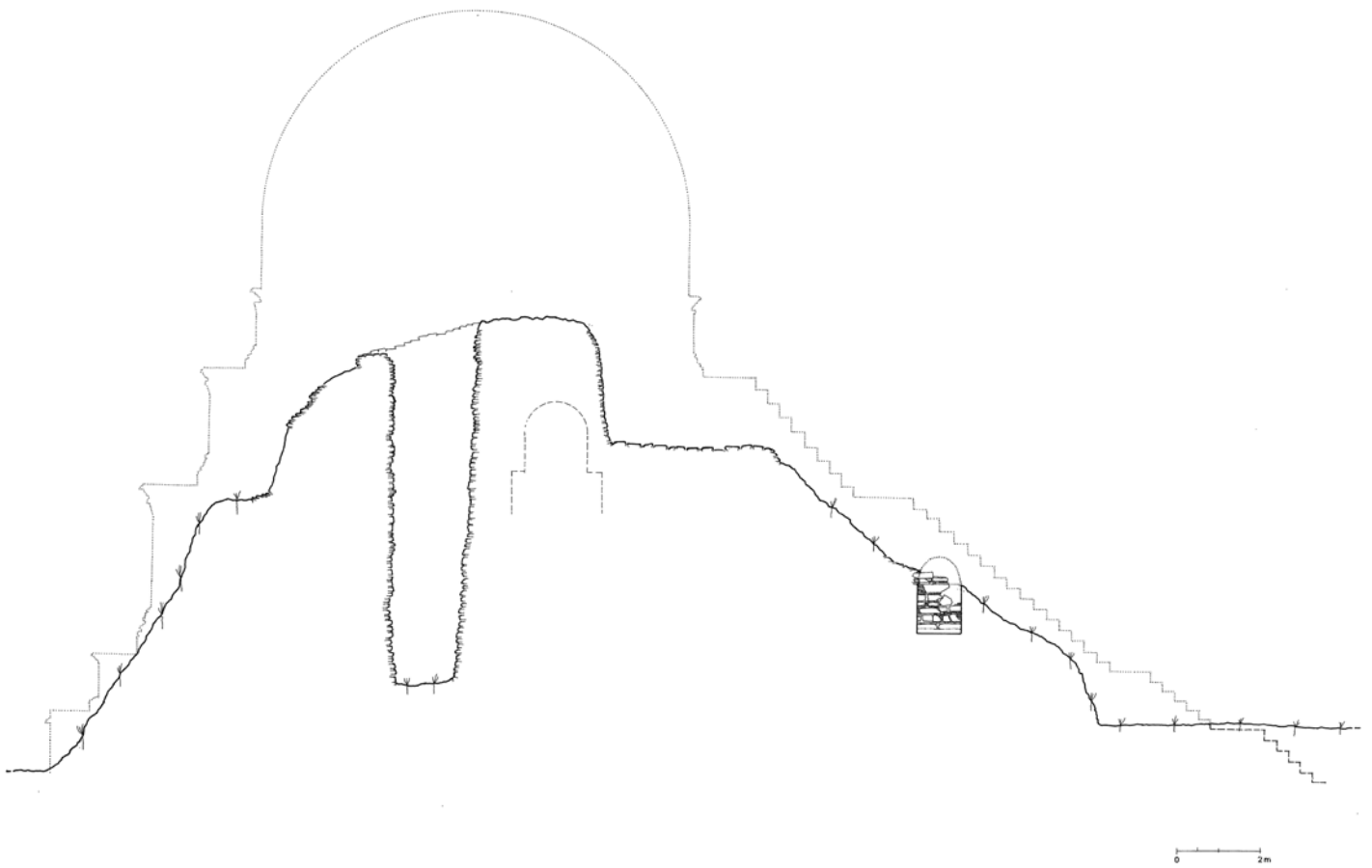

Fig. 61. Stupa of Loebanr. E-W cross section. (Sabelli 1993, 1996; Martore 2003).

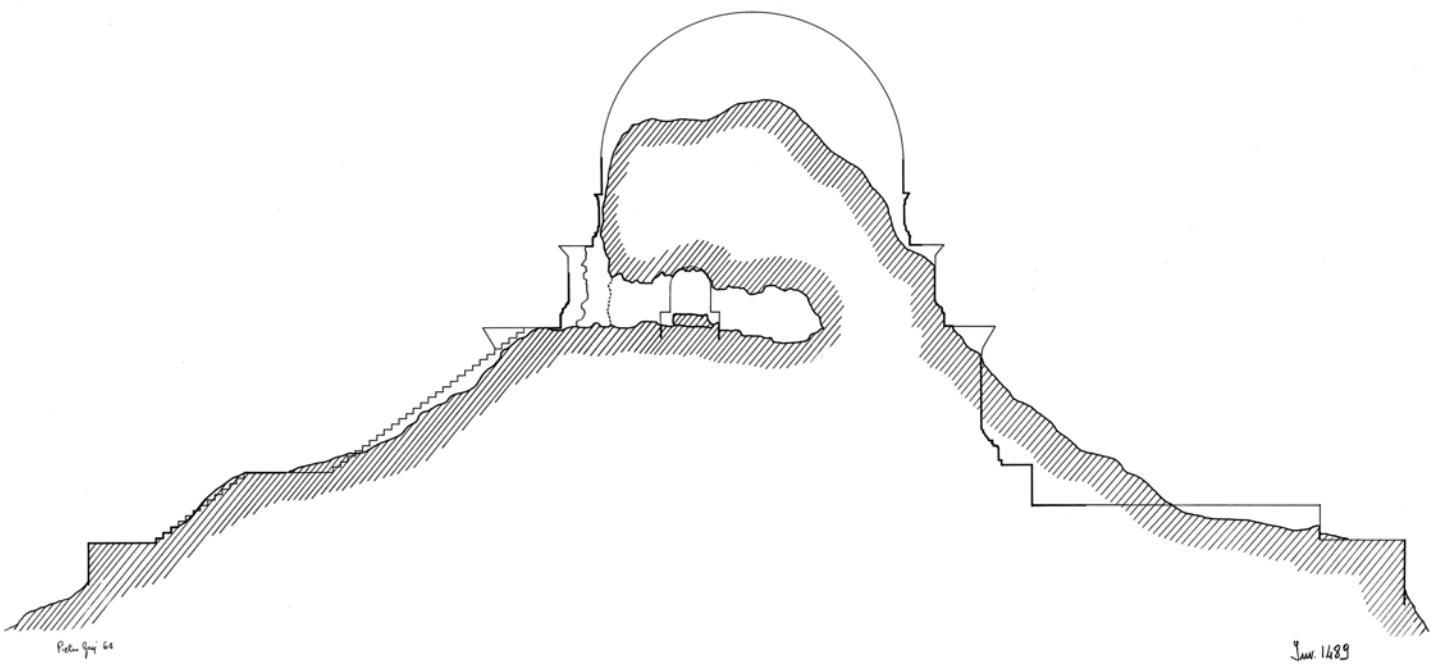

Fig. 62. Stupa of Loebanr. E-W cross section. The surviving parts are rendered with a thicker line. (Gui 1964).

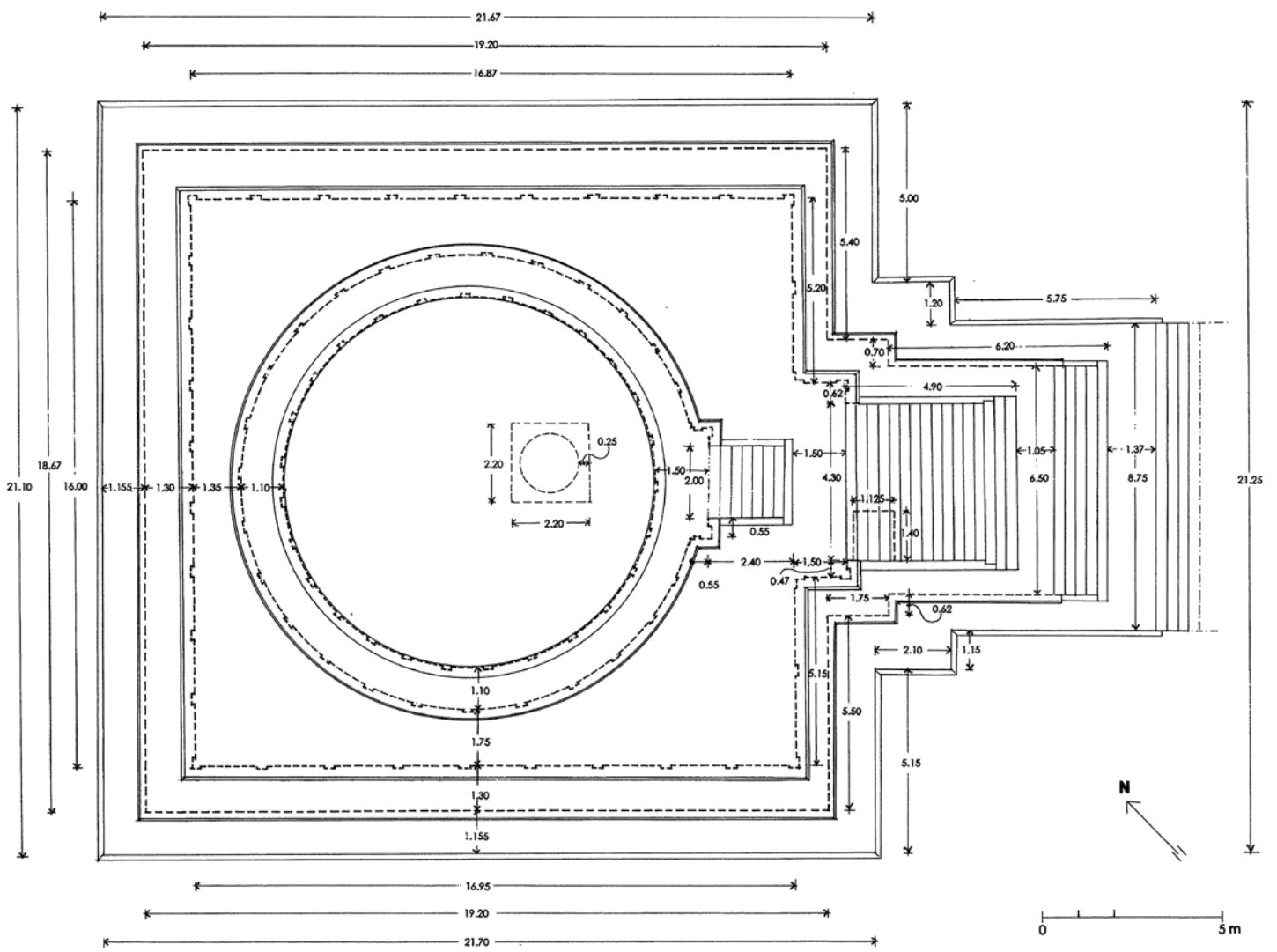

Fig. 63. Stupa of Loebanr. Sketch plan showing the measures. (Martore 2003).

A. Stupas

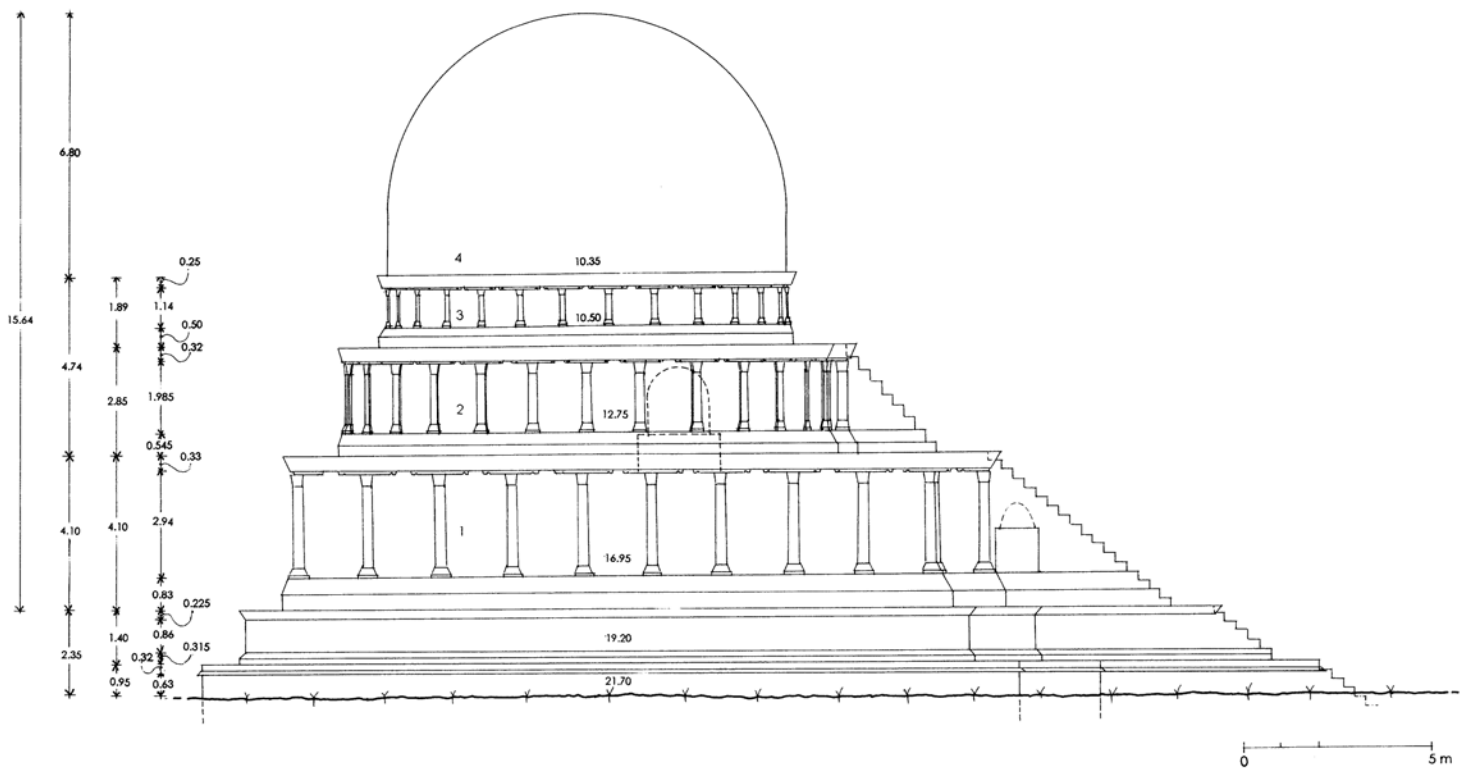

Fig. 64. Stupa of Loebanr. Sketch elevation showing the measures. (Martore 2003).

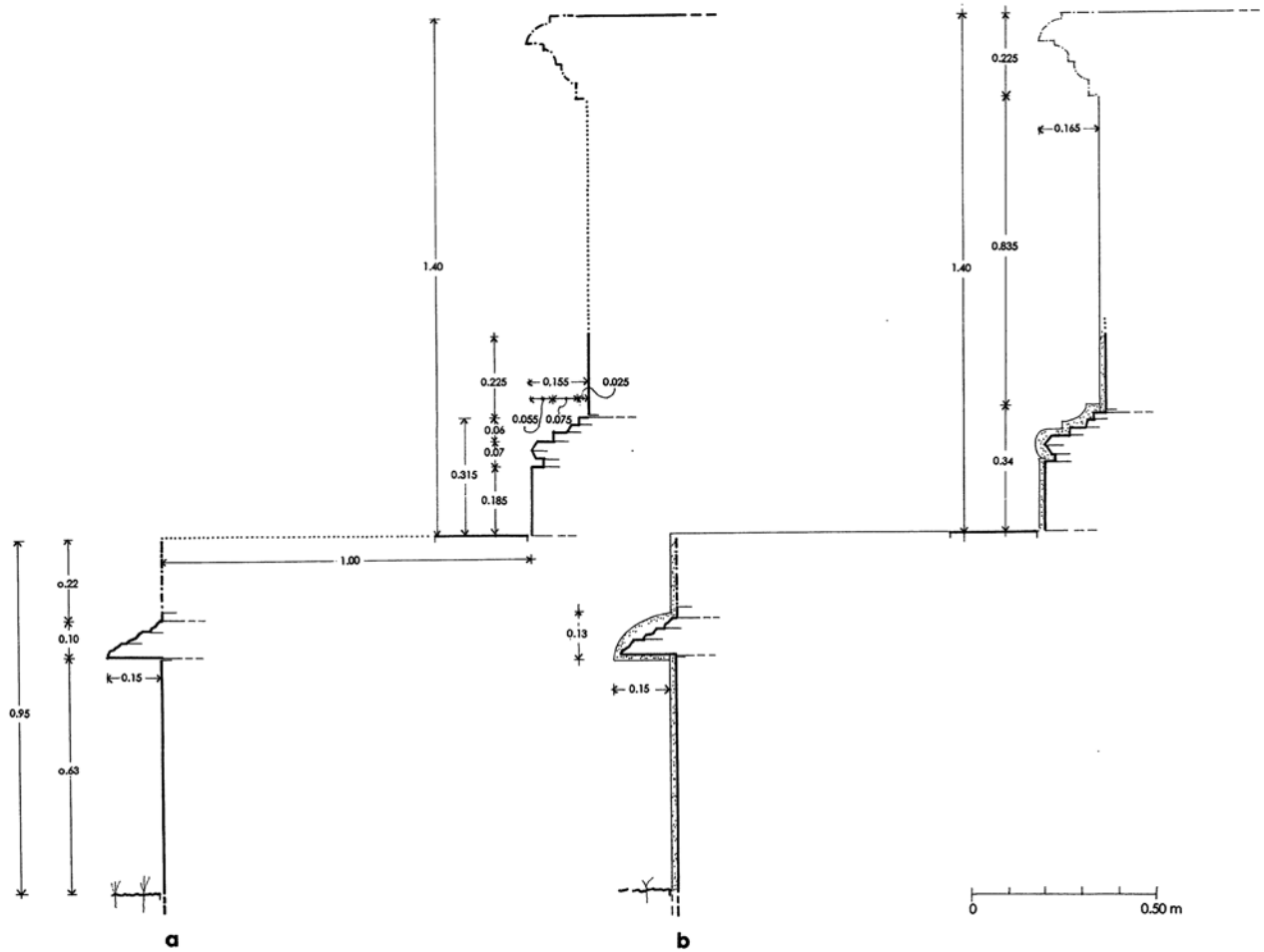

Fig. 65. Stupa of Loebanr. 1st and 2nd platform. *a.* profile. *b.* reconstructed profile, with plaster. (Sabelli 1993; Martore 2003).

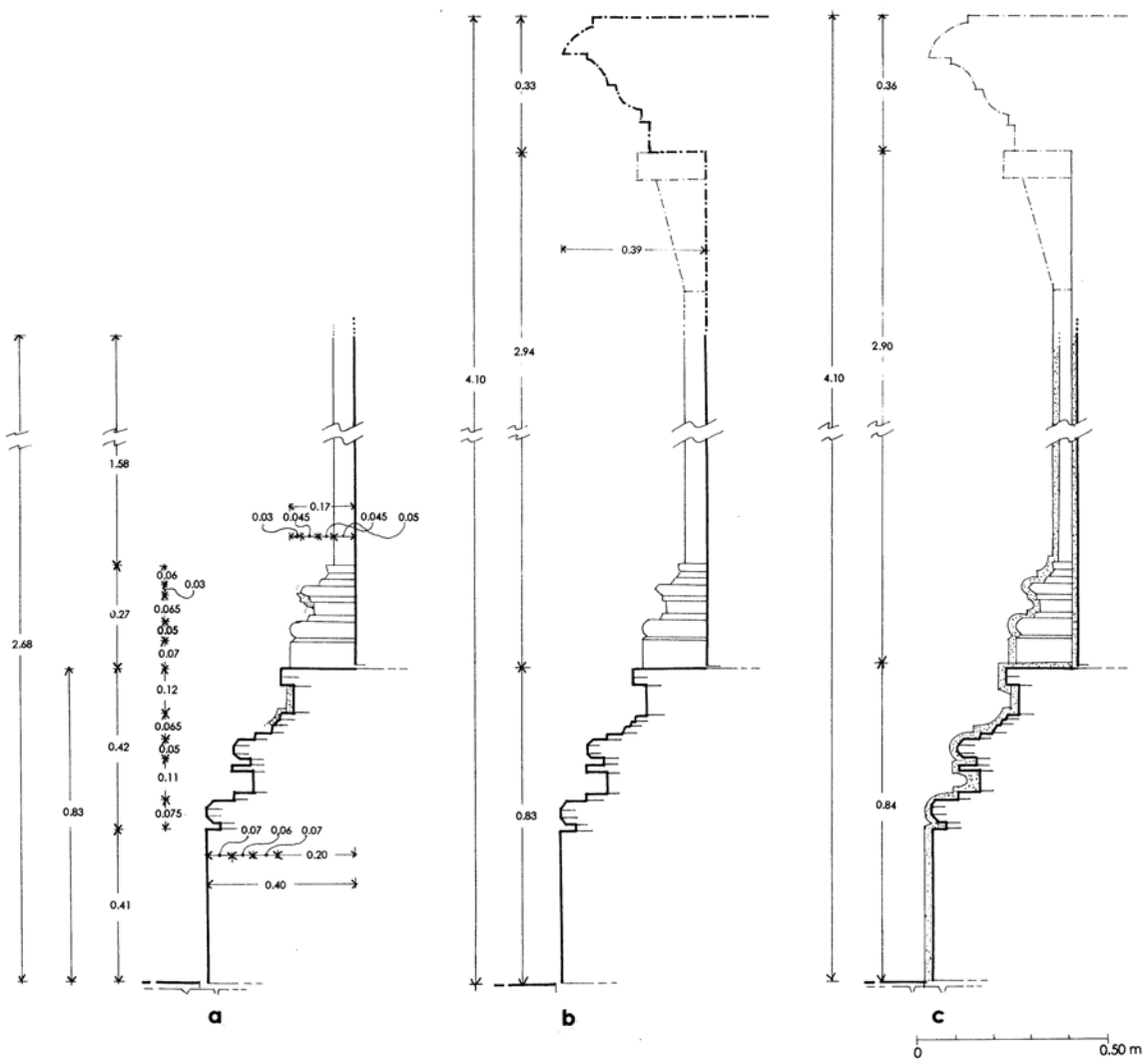

Fig. 66. Stupa of Loebanr. 1st storey. *a.* profile. *b.* reconstructed profile, without plaster. *c.* reconstructed profile, with plaster. (Sabelli 1993; Martore 2003).

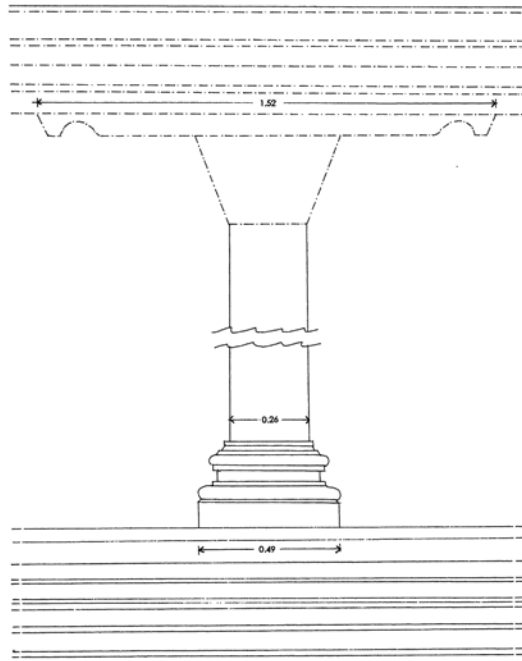
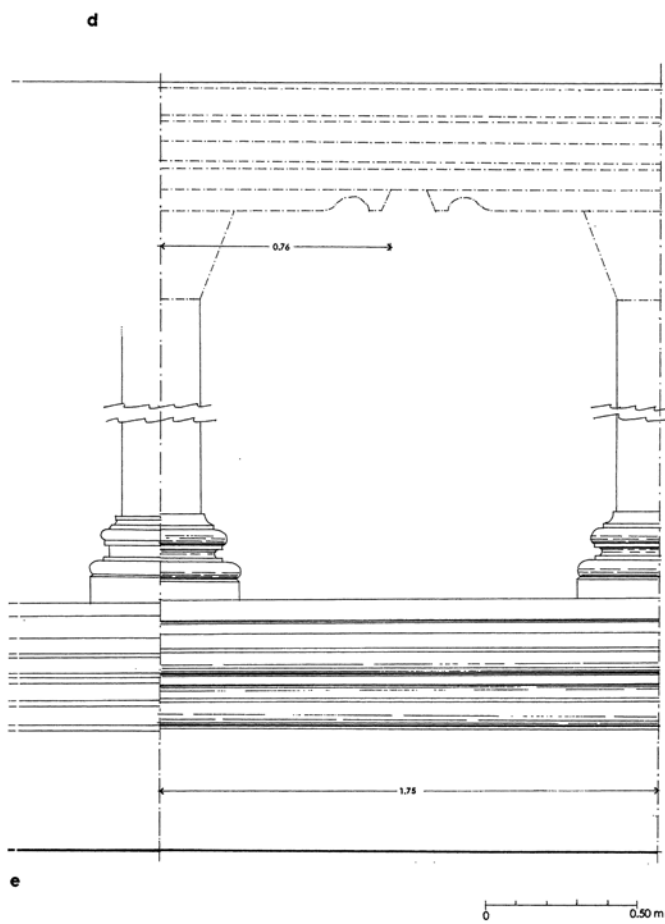
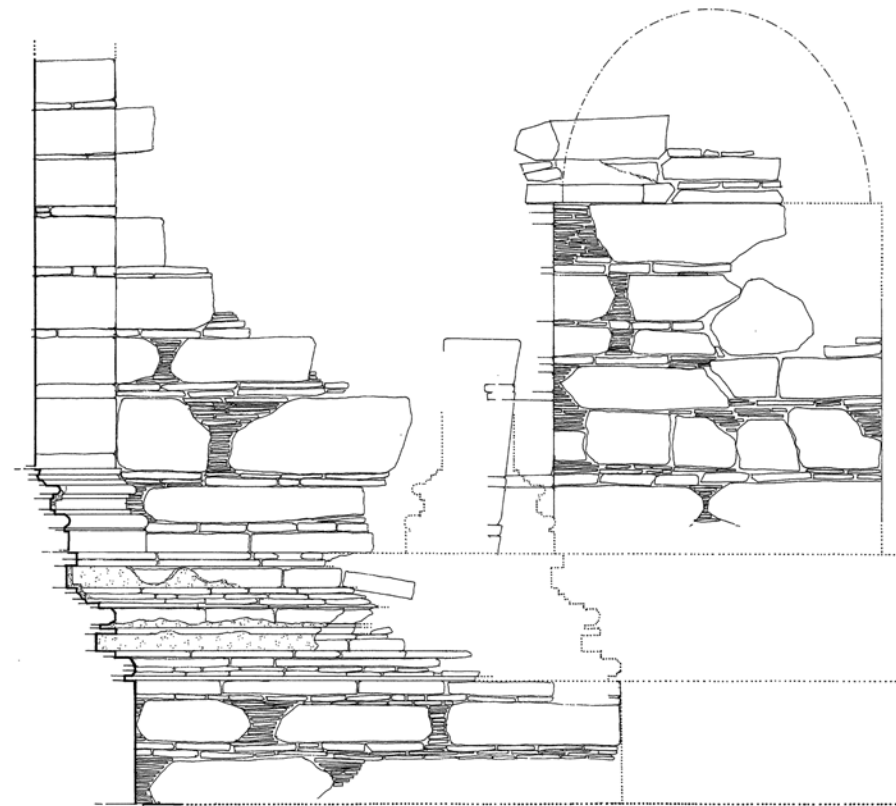
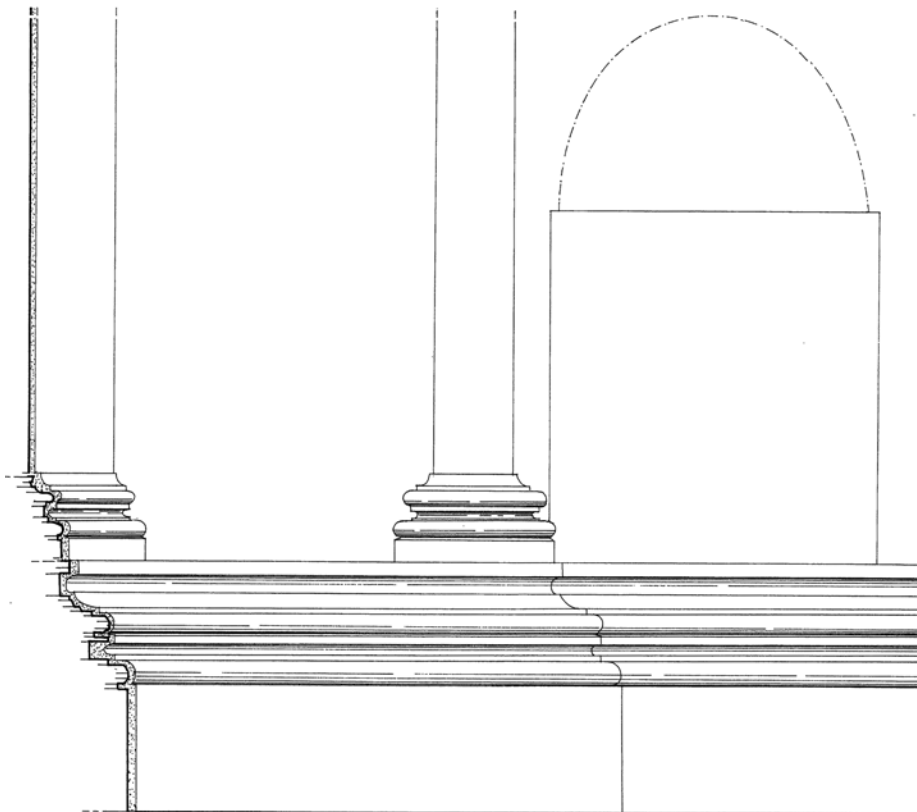

Fig. 67. Stupa of Loebanr. 1st storey. *d.* elevation showing base, pilaster and cornice. *e.* elevation showing the centreline of the pilasters. (Sabelli 1993; Martore 2003).





a



b

0 0.50 m

Fig. 68. Stupa of Loebanr. 1st storey. *a.* elevation showing the stairway projection, S side, and cell. *b.* reconstructed elevation showing the stairway projection, S side, and cell. (Sabelli 1993; Martore 2003).

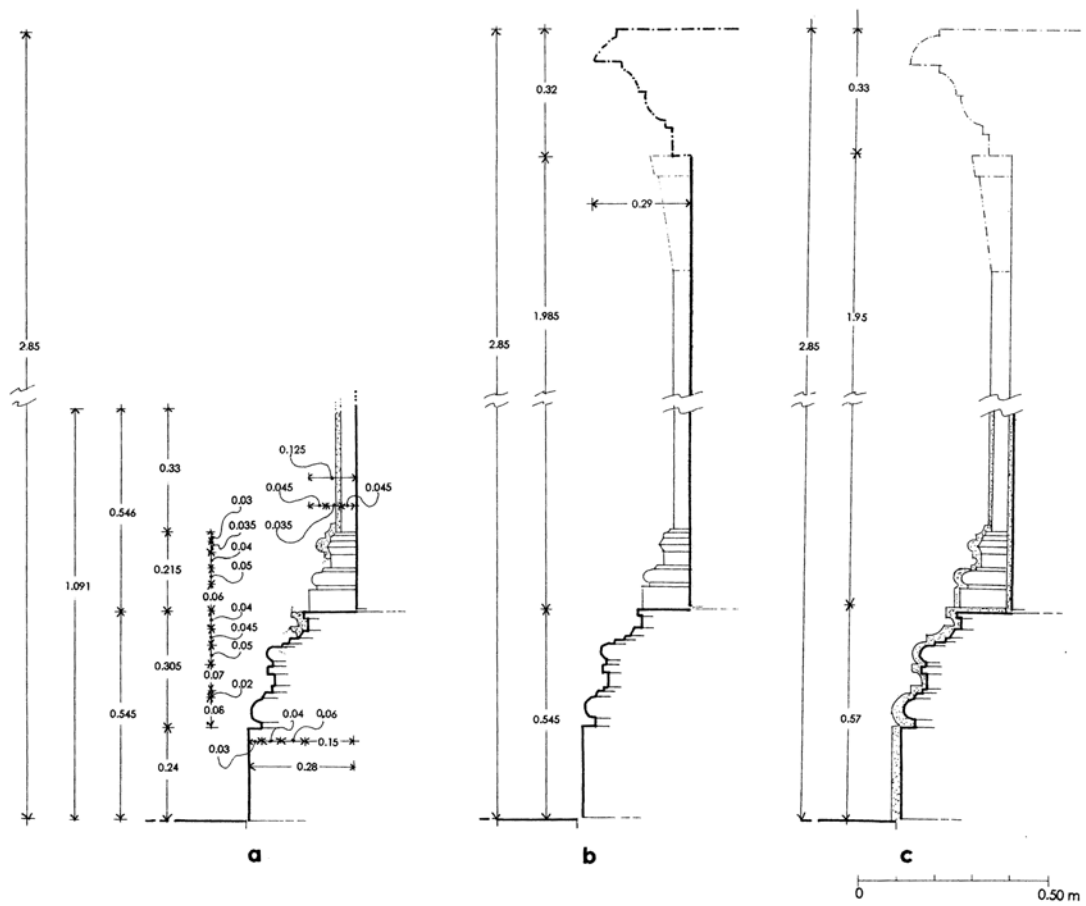
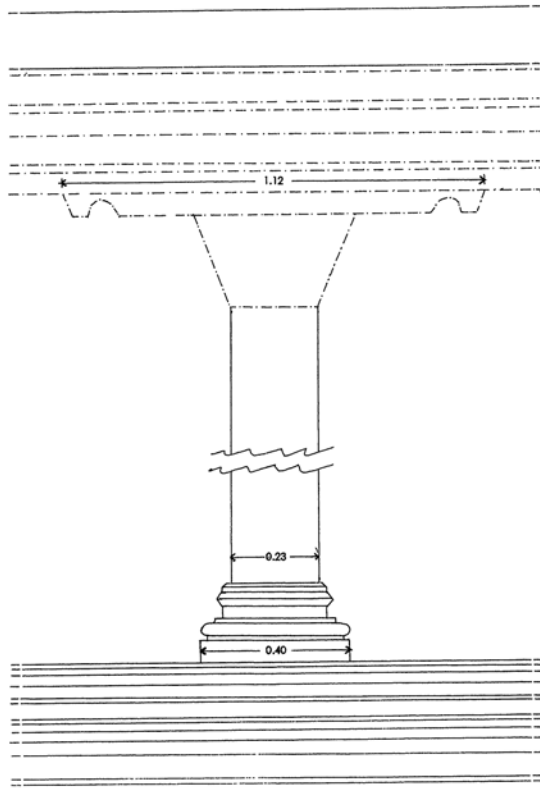
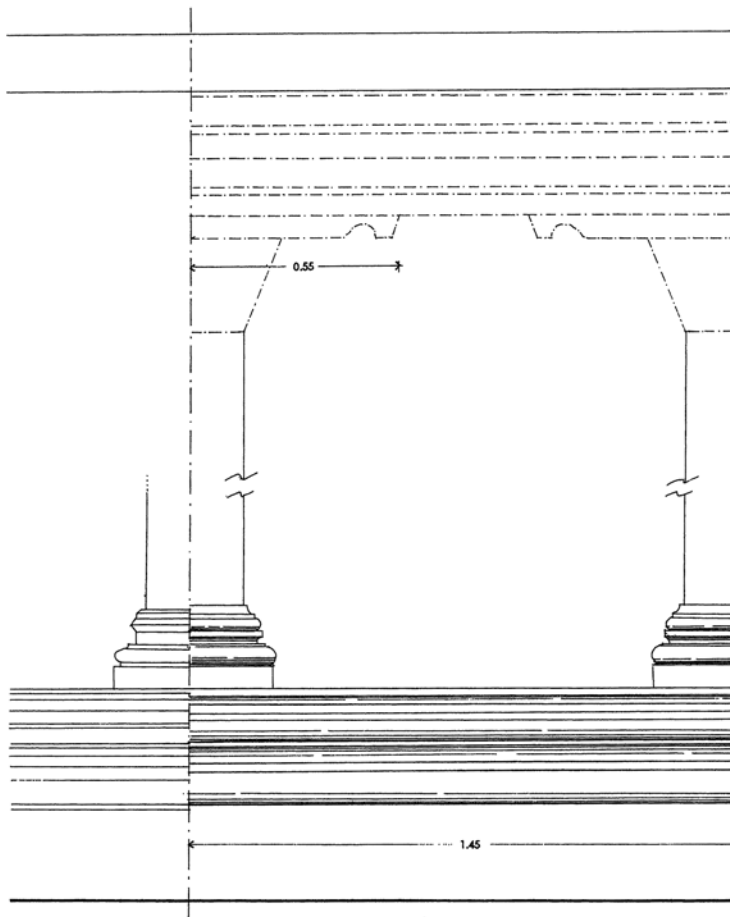

Fig. 69. Stupa of Loebanr. 2nd storey. *a.* profile. *b.* reconstructed profile, without plaster. *c.* reconstructed profile, with plaster. (Sabelli 1993; Martore 2003).

A. Stupas



d



e

0 0.50 m

Fig. 70. Stupa of Loebanr. 2nd storey. *d.* elevation showing base, pilaster, cornice. *e.* elevation showing the centreline of the pilasters. (Sabelli 1993; Martore 2003).

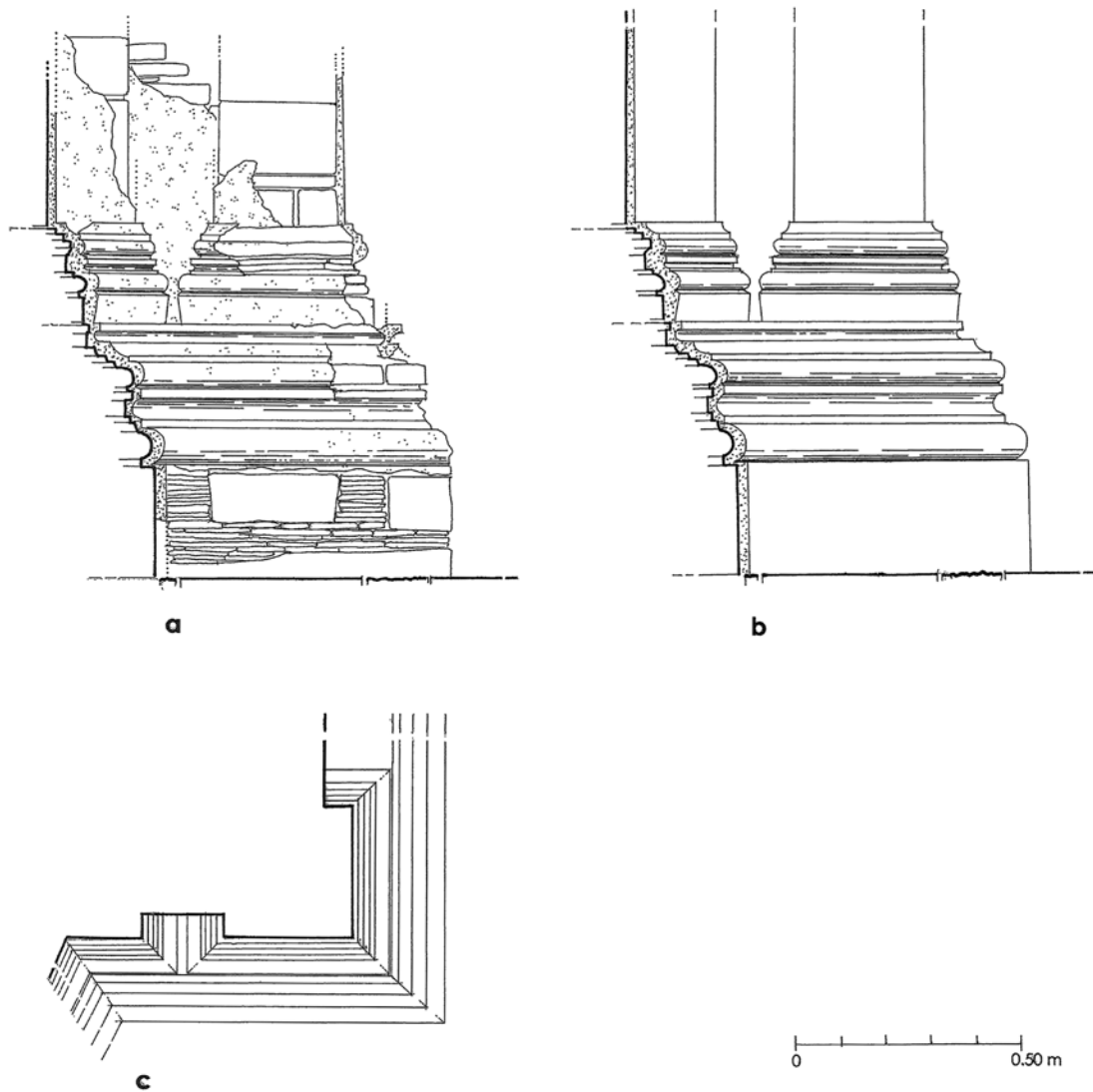

Fig. 71. Stupa of Loebanr. 2nd storey. Projection of stairway, S side, showing pilasters in the inner (between storey and projection) and outer (of the projection) corner. *a.* sketch drawing. *b.* reconstruction with plaster. *c.* plan. (Sabelli 1993; Martore 2003).

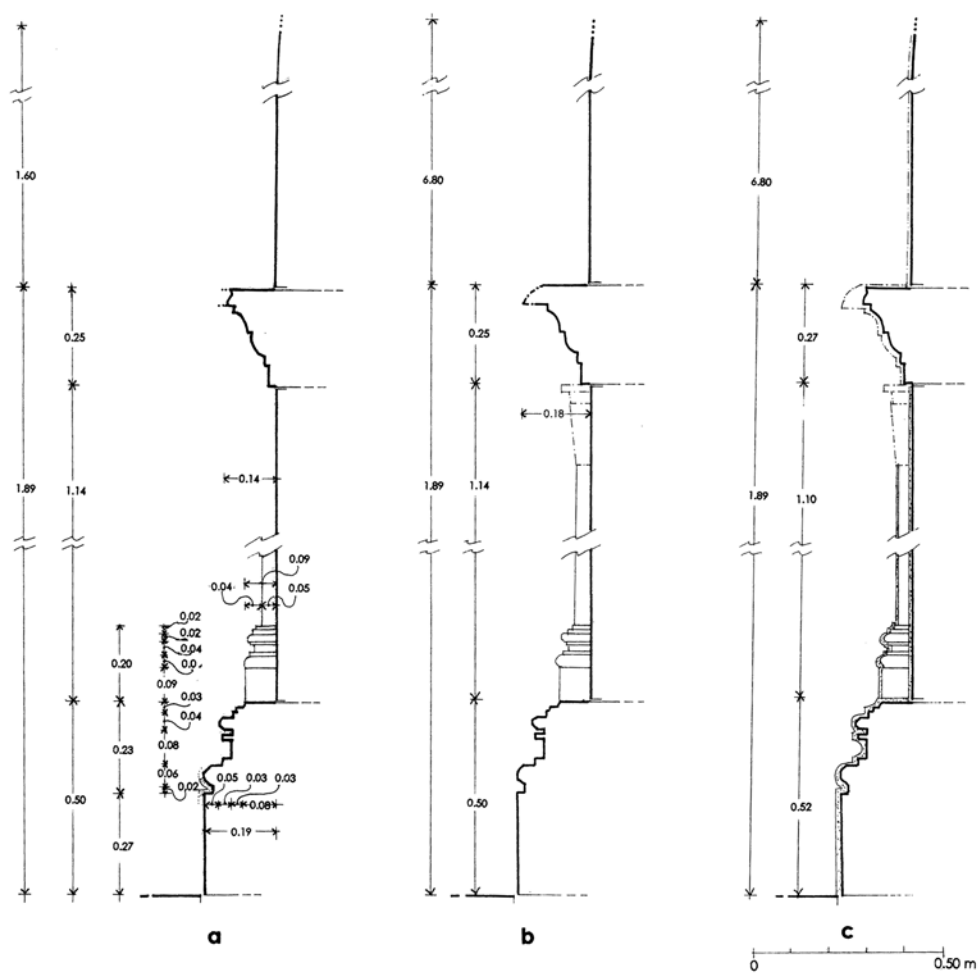

Fig. 72. Stupa of Loebanr. 3rd and 4th storey. *a.* profile. *b.* reconstructed profile, without plaster. *c.* reconstructed profile, with plaster. (Sabelli 1993; Martore 2003).

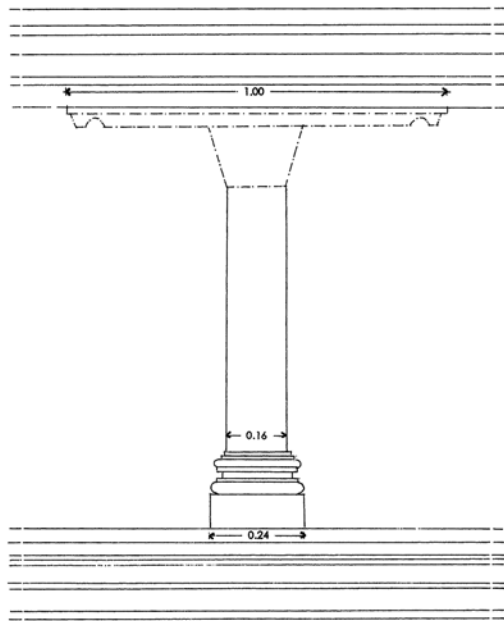
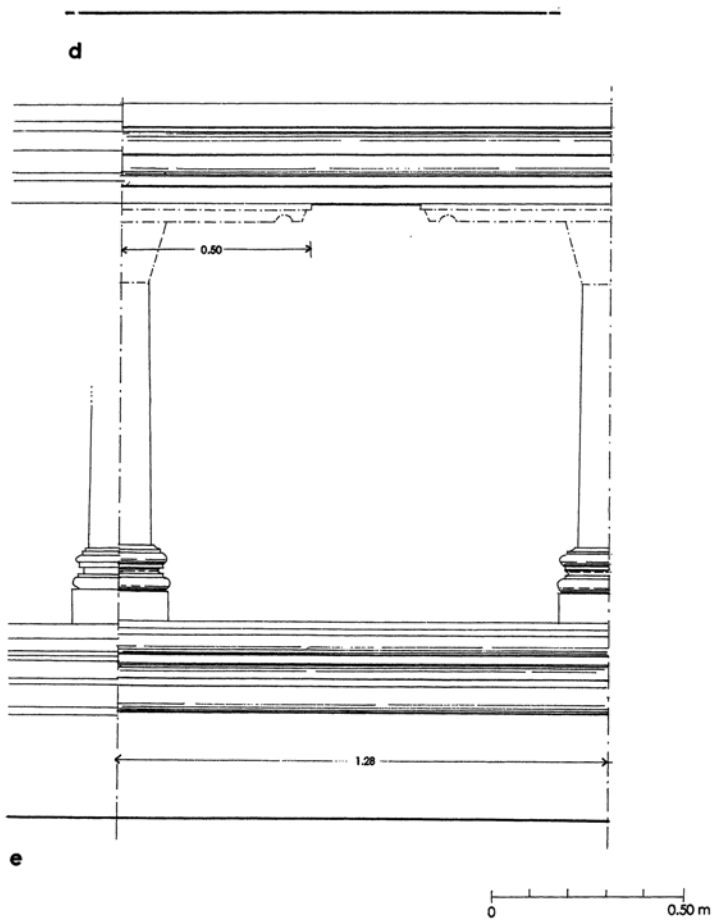

Fig. 73. Stupa of Loebanr. 3rd storey. *d.* elevation showing base, pilaster, cornice. *e.* elevation showing the centreline of pilasters. (Sabelli 1993; Martore 2003).



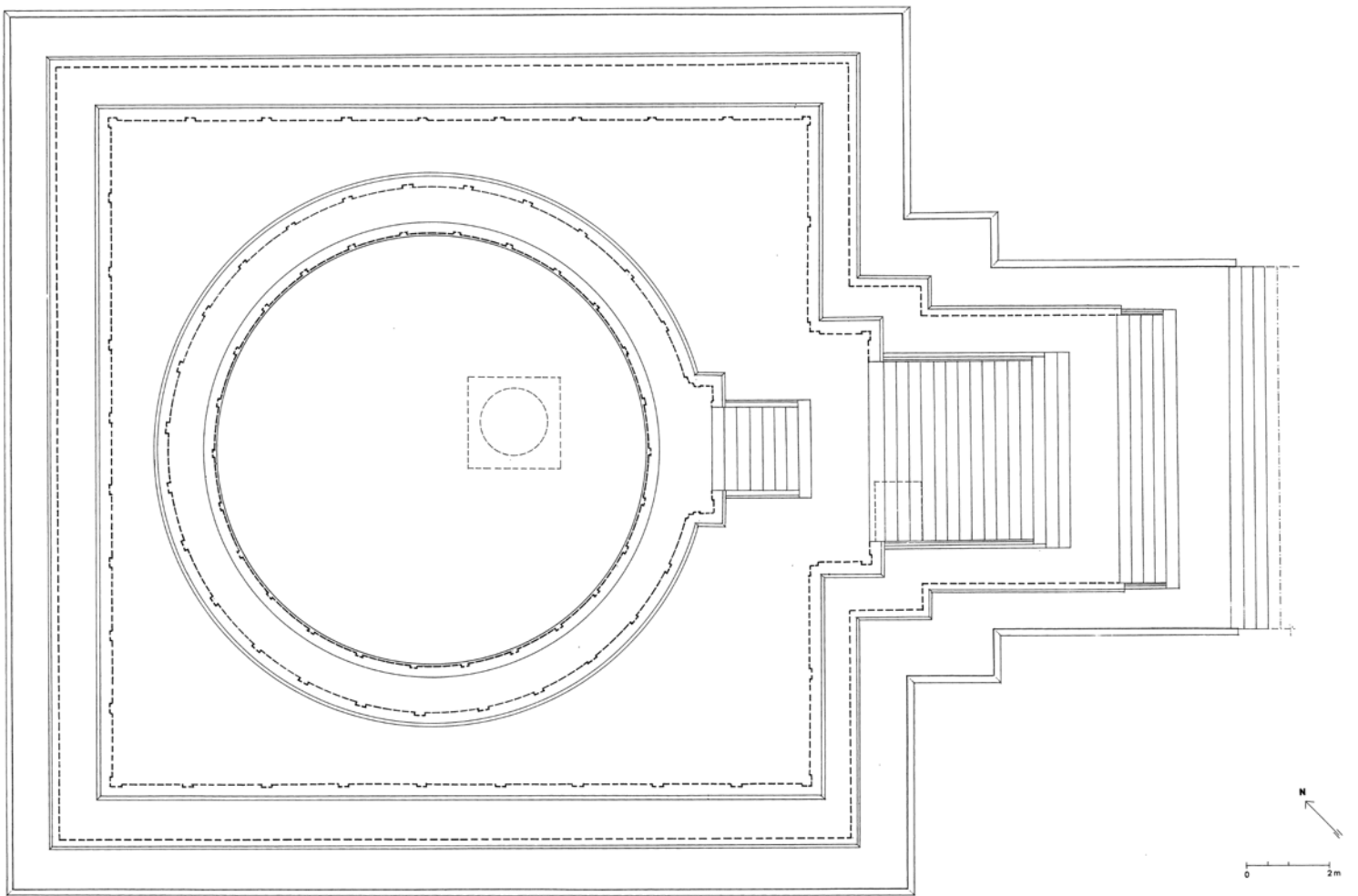

Fig. 74. Stupa of Loebanr. Reconstructed plan. (Sabelli 1993; Martore 2003).

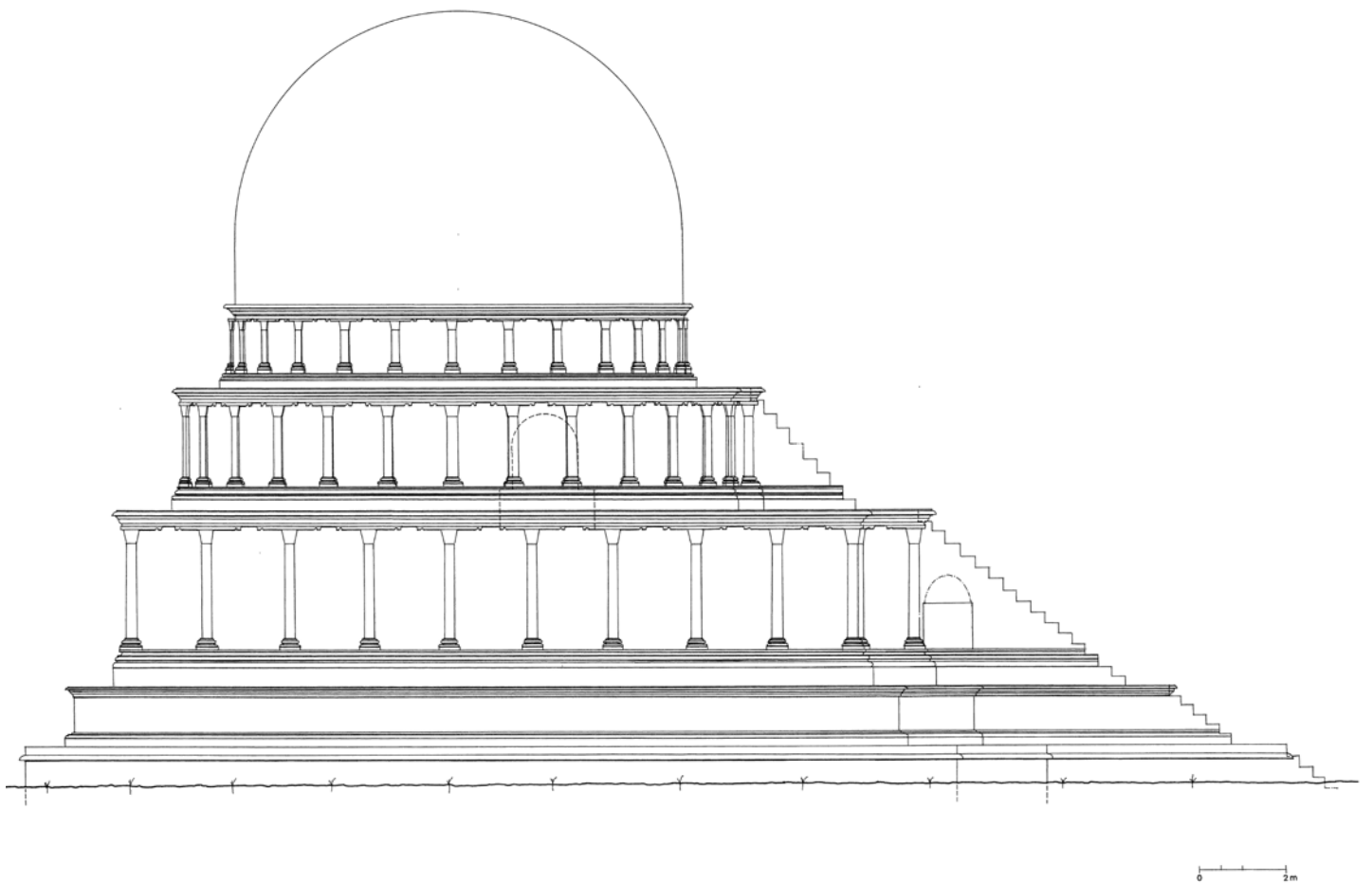

Fig. 75. Stupa of Loebanr. Reconstructed elevation. (Sabelli 1993; Martore 2003).

A. Stupas

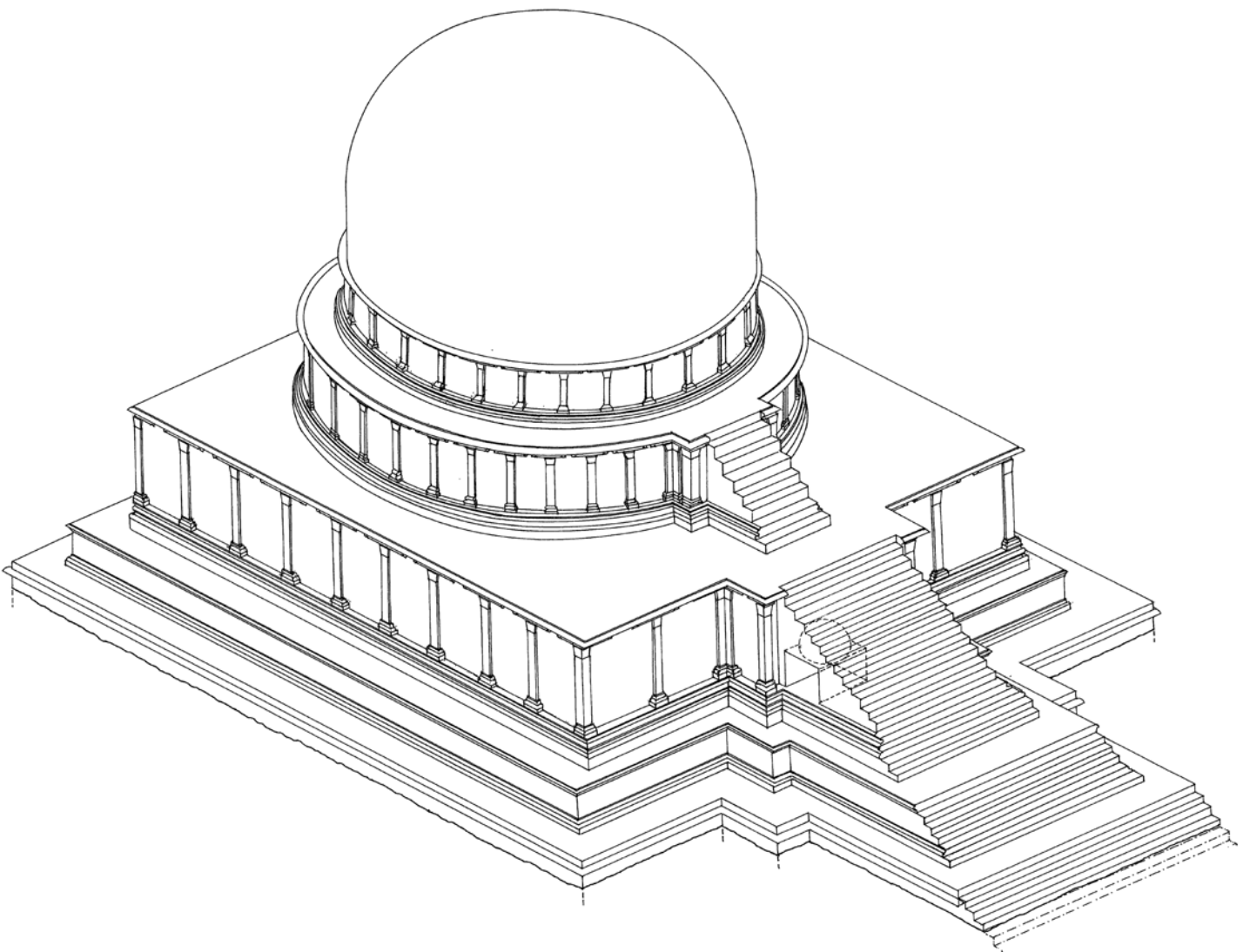

Fig. 76. Stupa of Loebanr. Axonometric view. (Martore 2003).

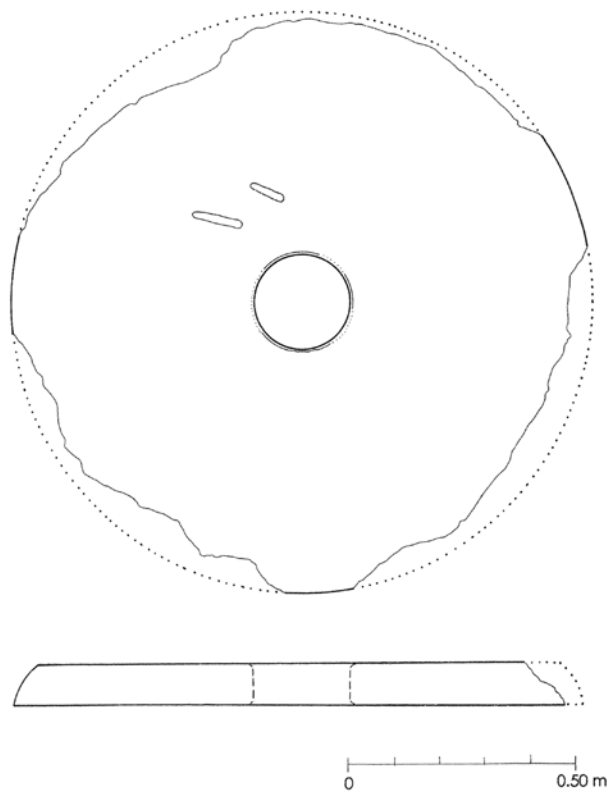

Fig. 77. Stupa of Loebanr. Chattravali disk. (Sabelli 1993).

A4. The stupas of Arapkhanchina (Shararai)

(Figs. 78-126)

The Site

Zone of Jambil-Saidu. Jambil Valley.

Position: Lat. 34° 43' N; Long. 72° 23' E; SPM 43B/5.

In the Jambil Valley, again on the left bank of the river, coming from Mingora, passing through the areas of Butkara I and Butkara III, before reaching Loebanr, a road leads off into a side valley and climbs before ending at a spot where a small school building now stands. The road narrows to a path, which continues to climb towards a large terraced open space.

The area, dotted with a few houses and a mosque, consists of small cultivated fields, bounded to the S by the cliffs of Mt Shararai and containing a large Buddhist complex. A short distance away a spring (or several springs) is situated along a lane at a slightly lower altitude.

Bibliography and Documentation

Stein 1929: 74, figs. 38 (rock carving), 40 (general view) ⁽¹⁾; 1930: 45-46, figs. 30 (viewed from W looking E with stupa III in the foreground and stupa V behind, left), 38 (rock carving), pl. 71 lower right ⁽²⁾.

⁽¹⁾ 'There were numerous Buddhist ruins also in the Jambil valley through which the route from the Khal'i pass leads down to Mingora. There we found nearly a dozen ruinous Stūpas scattered in little groups; all had suffered badly because their accessible position had made them convenient quarries of building-stone (figs. 38, 40). It was probable, too, that iconoclastic zeal would assert itself with special vigour in a populous neighbourhood'.

⁽²⁾ 'Here we left this Nullah and ascended over steep rocky slopes to a gully on the crest of the spur towards the Jambil valley. Descending from here some 600 feet we reached a small plateau situated between two torrent beds and facing the village of Pāṇ in the valley below. It bears a Buddhist site of obvious importance marked by not less than six Stūpas, and known as Sharārai, from a spring close to one of these. The Stūpas, as the sketch plan (pl. 7) shows, are scattered over an area measuring about 200 yards from east to west and some 170 yards across; they have all been dug into and are badly destroyed, as seen in fig. 30. Only two of them,

In his sketch map Stein indicates six stupas, numbered from I to VI, a numbering that has been retained. Of these stupas only numbers IV and V have conserved sections of the wall; beside no. II lies a chattra. To the S of the complex (S of no. III) lie substruction walls of a terrace apparently occupied by a shrine, no longer extant. He then describes the rock relief, fig. 38.

Tucci 1958: 310, fig. 18 (rock sculpture) remarks on the size of the area, the spring, the remains of five stupas and the rock sculpture, fig. 18, now completely uncovered ⁽³⁾.

Gui and Cimmino 1965: they performed a survey with a cross section of the area and the survey of no. II.

Faccenna 1976: field notes; 1980-1981: 755, n. 2.

De Marco 1982: photographic reconnaissance.

Olivieri 1989: photographic documentation (in Filigenzi 2014).

Reconnaissance (1990) by geologist group with Sergio Lorenzoni, Eleonora Zanettin Lorenzoni, Claudio Faccenna, Maria Rosaria Di Florio; examination of no. II and photos. For the geological work of the group in Swat — 1989-1990 — see Faccenna, Nabi Khan and Nadiem 1993: Appendix D; Faccenna 1995a: 26 and Appendix E with Bibliography).

Olivieri and Nascari 1991: reconnaissance.

Sabelli 1993: graphic survey with overall map and cross sections of the area and with complete documentation of the individual monuments.

Martore 2004: verification of measures, corrections, graphical updating of symbols.

De Chiara 2007: photographic documentation.

iv and v, have preserved at least some remains of the facing masonry of their domes. It is only in the case of the second that the diameter of the dome could be roughly determined, it being about 33 feet and the extant height over 22 feet. The plan shows the approximate diameter of the mounds left; these, no doubt, comprise also portions of the bases. The complete ruin of the Stūpas clearly proves that quarrying operations had been carried on here for the benefit, not perhaps of Mingaora but of the villages nearer by in the valley. Below the mound formed by Stūpa ii there lies a circular stone, 8 feet in diameter, evidently one of the Chattras which crowned the Stūpa. To the south of these ruins a large platform, partly artificial partly resting on walls, stands to a height of about 20 feet. It appeared to have been occupied by a completely destroyed shrine. Beyond the plateau which carries these ruins there rises on the north a small rocky ridge extending about 140 feet in length from east to west. It is covered with debris from walls of decayed quarters; plentiful potsherds of ancient type lie among them'.

⁽³⁾ 'Shararai, now known by local people as Arap khan [...] is particularly interesting because the ruins are scattered over a very large area and testify to the existence in this place of a very extensive religious settlement, built near a spring still flowing with perennial water.

'The importance of the locality is testified not only by the ruins of buildings and the remains of the five stupas but also by the rock carvings: these are more numerous than those referred to by Stein. One of them was partly covered when Stein noted it, but now it has been completely unearthed and it is certainly one of the most interesting to be seen in the country: the main group represents a Buddha on sim'bhāsana between two Bodhisattvas standing on a lotus (fig. 18)'.

The Stupas

Stupa I

On a terrace below the level of the one on which no. II is built lies a substruction wall, portions of which are visible on three sides and in the NW corner. The wall rises, set back in three steps formed in the short space of the recess by several projecting slabs or by inclined blocks; the block and slab technique is used.

Nothing is visible on the plane supported by the walls, which has been levelled out and tilled.

The general plan view and cross section show the perimeter walls and, in the inner area, a second circle, as suggested by Stein in his sketch map, pl. 7 ⁽⁴⁾. However, it cannot be ruled out that the substruction walls were for a terrace and that the latter had another function (occupied by monastery buildings?).

The wall profile is viewed from the S side (upper part of the sketch), the N side (lower part), where it is better conserved. The distance between the two projecting parts (upper and lower) is c. 1.60.

Stupa II

1st Storey, Quadrangular in Plan

The base moulding, badly broken up, is visible in the NW corner and in a short section to the N. It has a plinth, torus and cavetto obtained from two blocks of talcoschist; the wall is missing while further back the well aligned core is visible, suggesting a masonry which was not to be seen; the core of the bearing plane is thus left bare in the space in between. The base is supported by projecting schist slabs with a plumb wall that probably becomes a substruction wall, needed to offset the unevenness of the ground; the block and slab technique is used.

The calculated height of the storey is 2.90. The stairway is situated on the E side, viewed in the remains by Gui and Cimmino in 1965; the measures given below are taken from their sketches and correspond to the stairway, in this case of the 1st storey, which is rectangular in plan. The steps are estimated as 12 in number with an inclination of 37°.

⁽⁴⁾ With reference to its identification as a stupa. The set-back walls could well be inner substruction walls, as has been noted elsewhere (see stupa V).

2nd Storey, Circular in Plan

Set back by 3.15 on the W side and by 2.425 to the S, a section is reasonably well conserved on the E side, including the base with plinth, torus and cavetto, each obtained from a single talcoschist block; it rests on a plane of schist slabs forming the floor.

Again to the E the wall is conserved for two rows of talcoschist blocks, in ashlar technique, bearing traces of plaster; it is set back slightly with respect to the base cavetto. It displays the recess characteristic of a projecting body, probably at the junction with the stairway (1976), thus confirming what Gui and Cimmino observed in 1965; the measures given were taken from their sketches. The steps are estimated as 7 in number with an inclination of 38°.

3rd Storey, Circular in Plan (Drum)

Set back by 0.825 on the N side is a short section of the circular storey with a poorly conserved base consisting of plinth, torus and cavetto made of talcoschist blocks, in ashlar technique. Short section of elevation of the wall made of talcoschist blocks and schist slabs.

The base displays projecting schist slabs with facing, resting on the core.

There is a recess in the upper part of the wall, where the curvature of the dome begins, probably the remains of a cornice (?).

4th Storey, Raised Dome

Conserved over a short section; built using block and slab technique. The core continues up to a certain height, with a depression in the centre (4.00 from the base of the 3rd storey; 3.45 from its conserved top).

Chattravali Disc

On the ground near the stupa, at the height of the 2nd storey, lies a large sloping disk of fine-grained gneiss; diam. 2.56, thickn. 0.27 with an edge having an ovolo profile. The visible surface is the same as the lower, without a hole; the rear one, with its upper section only partly visible, slopes gently at the edges and it is not possible to see whether a hole is present.

It is important to note the presence of two different masonry techniques: ashlar with talcoschist blocks and with schist blocks and slabs; the former appears to have been used in the first two storeys, and the second in the others. This might suggest the monument was restored, although this does not rule out their contemporary use.

The presence of different materials in the same monument is found also in stupa VI.

Stupa III

1st Storey, Quadrangular in Plan

A short section has been conserved on the N side. It is not a structure meant to be visible, as is apparently suggested by a few sections of the core that extend beyond its alignment.

2nd Storey, Circular in Plan

At a slightly higher level and set back by 2.75, a short section is visible on the W side, consisting of a plinth, from which a smooth wall, slightly set back, rises; max. h. 0.90, tot. max. h. 1.36. It is supported by the certainly projecting core of the 1st storey. The gneiss block and slab technique is used; there are no visible mouldings. Also this structure, like the lower one, was not supposed to be visible, as both the masonry technique used and the absence of mouldings with a simplified profile seem to indicate.

Assuming that the distance of the facing wall from the non visible one may be estimated as 0.50, for both the 1st and the 2nd storeys, as we know the height of the 2nd with respect to the 1st, we can reconstruct the profile of the monument with the quadrangular 1st storey as having a side length of at least 20.00, and the 2nd storey as having a diameter of 14.50, set back by 2.75. It is interesting to observe this construction system with inner walls, also found in other cases (Butkara I; Abbasahebchina) (see stupa V).

We know the height of this partly buried and largely destroyed monument which is only just visible in an intensely farmed area.

We do not know the length of the 1st storey, assumed to be square in plan. It does not exclude the presence of a stairway (as in the case of stupa V), conceivably on the E side.

For the 1st storey the following are rendered in the reconstruction: base, wall, internal structure.

Stupa V

1st Storey, Square in Plan

In the soil mound a rectilinear stepped structure is visible on three sides, five steps to the E, four to the W, three to the N, short sections to the S, set back slightly as it increases in height. The structure was not meant to be visible but was internal, as has been observed elsewhere. On the S side an outwardly extending core could well correspond to a stairway. The storey, on the basis of the internal

measures, seems to be square in plan with a side length of 16.20; together with this storey, the presence of a stairway should be noted, the latter usually connected to a rectangular storey (cf. stupa III), with a hypothetical ramp of 7 steps (exposed height) and with an inclination of 39°.

2nd Storey, Circular in Plan

At a higher level, on the N side, a short cleaning session revealed a section of curved structure including a wall with a projecting plinth supported by a thick projecting slab. Separated by earth and stones (core?), it overlies a structure displaying a straight wall running E-W made of blocks and slabs. The latter probably belongs to the square 1st storey, and then joins the stepped structure; it thus shows how the stepped composition began immediately after the base of the 2nd storey.

On the basis of the height measured at the springer of the circular storey and the base of the steps, we can get an indication of the maximum conserved height of the two storeys. The core continues for a short distance (2.15) with a depression at the centre corresponding to the typical cavity made while searching for the reliquary (1.35 from the top of the core). An approximate assessment of the distance between the inner and outer walls allows the profile and the volume of the monument to be reconstructed.

In the hypothetical reconstruction, an indication is given of the 3rd storey, set back by an average distance calculated as probable.

Stupa VI

Badly damaged, only short sections of the facing remain. A short section of the 2nd storey base is visible with plinth, torus and cavetto and a portion of the wall elevation; it is supported by projecting foundation slabs on the core of the storey below. Of the 3rd storey (drum) there are remains of the upper part of the block and slab wall held together by small slender transition slabs; it ends with the slender fillet and ovolo cornice, and reverse ovolo; it also lacks the coping slab, thereby indicating the end of the cylindrical storeys. On the N side, the wall starts again from the 4th storey (dome) with long closely packed talcoschist blocks, with a vertical profile, attaining the height di 0.96. At this height we find the centre of the diameter of the drum corresponding to the diameter of the semi-circle of the dome.

Here we have an opportunity to define the wall of the raised section and to outline a dome (h. 5.60), which does not happen very often. Its lines follow a hemisphere and it is raised on a vertical band (h. 0.95).

The entire E side of the stupa has been lost, while in the centre a cavity opens

from the top which extends beyond the upper level of the 1st storey. The visible part of the 1st storey consists in part of the core, the rest of which is buried. It is not possible to determine the probable presence of a stairway facing E.

The levels of the terrace on which the stupa stands are higher on the W and S sides; they are much lower on the E and N sides.

The core is made of earth and slabs and less noble material. Several rows of larger blocks are visible, probably corresponding to the bases and cornices of the various storeys. In the reconstruction of the stupa storeys the extent of the core projects can be used.

General Remarks

In a zone shut in to the S by mountains, open to the N on to the Jambil Valley with slight irregularities in the terrain there stands a sacred complex, from which several stupas emerge, in various states of conservation. In examining each monument it was attempted also to arrive at as plausible a reconstruction as possible.

The monuments are of medium size (14-20 m), provided with stairways, one of them with two, oriented in different directions; some have conserved their simple base mouldings (plinth, torus, cavetto), with three quadrangular or square storeys, two progressively receding circular storeys, the second of which is the drum, and a raised dome.

The cornice is documented only in stupa VI for the 3rd storey.

The construction technique involves extensive use of a systems of internal steps (stupas I, V).

Stupa VI is particularly important. The absence of a coping slab in the 3rd storey cornice confirms its identification as the drum. Moreover, the core, although badly deteriorated, practically rises to the full height of the dome, giving it its complete profile. The latter is hemispherical: this is a very important acquisition in the reconstruction of this kind of monument in general. It also provides us with its lower vertical part (profile and measures) specific to a raised type of dome. Lastly, it can be used as a chronological indicator regarding the changes undergone by the type over time.

The total absence of pilaster decoration should be noted.



Fig. 78. Arapkhanchina (Shararai). (After Stein 1930: fig. 30).

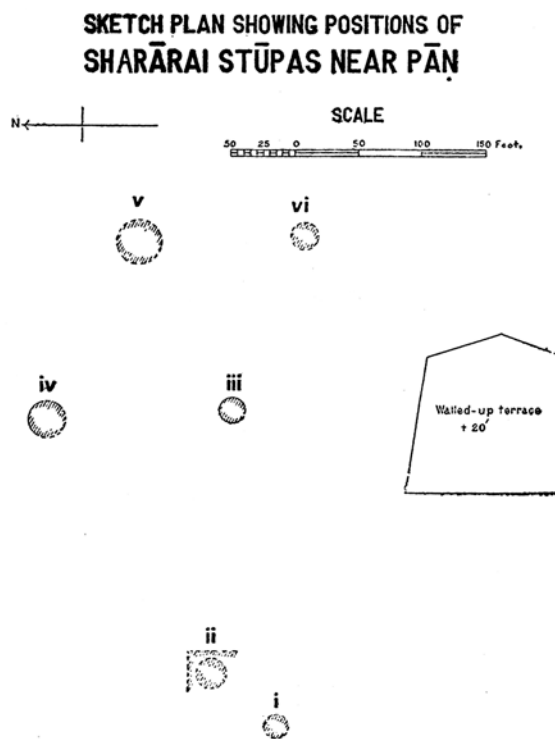

Fig. 79. Arapkhanchina
(Shararai). (After Stein
1930: pl. 7 on bottom
right).



Fig. 80. View from Arapkhanchina (Shararai) towards the valley. (Faccenna 1976; Neg. CS).



Fig. 81. View from Arapkhanchina (Shararai) towards the valley. (Faccenna 1976; Neg. CS).

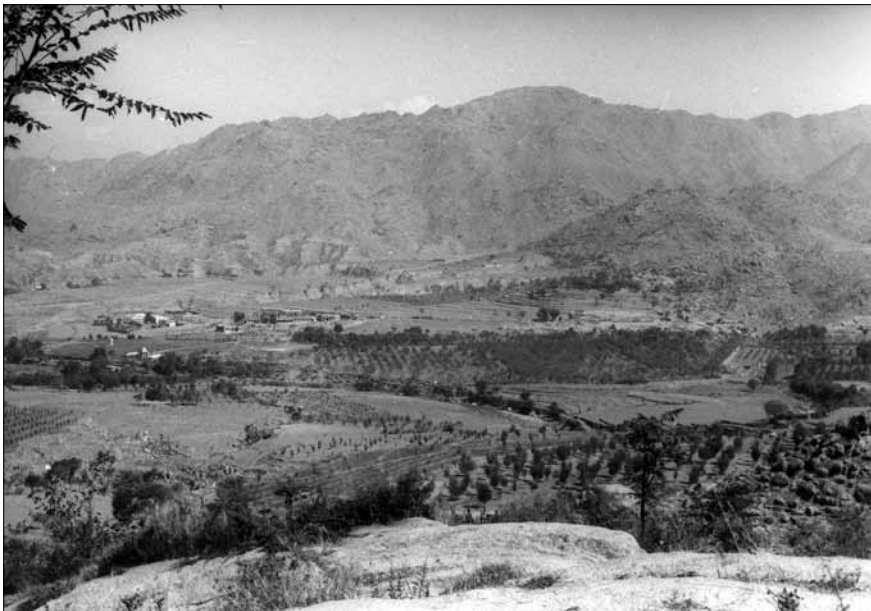

Fig. 82.
View from
Arapkhanchina
(Shararai)
towards
the valley.
(Faccenna 1982;
Neg. CS).



Fig. 83.
Arapkhanchina
(Shararai).
Substruction
walls.
(Kuwayama
1993).

A. Stupas

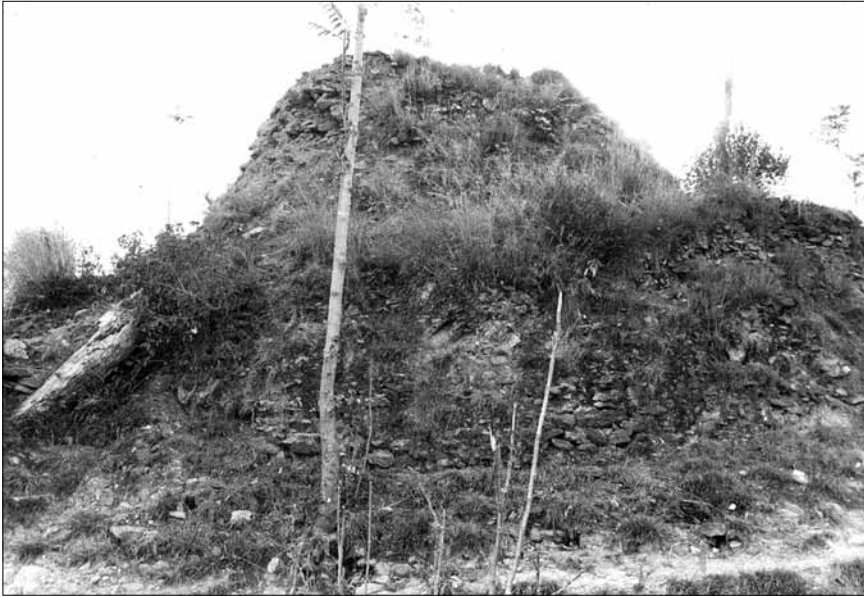

Fig. 84.
Arapkhanchina
(Shararai).
Stupa II. W
side, general
view; on the
left, chattravali
disk. (Nascari
1993 [?]; Neg.
CS).



Fig. 85.
Arapkhanchina
(Shararai).
Stupa II. 2nd
storey, N side.
(Kuwayama
1993).



Fig. 86. Arapkhanchina (Shararai). Stupa II. W side; chattravali disk. (Faccenna 1990; Neg. CS).

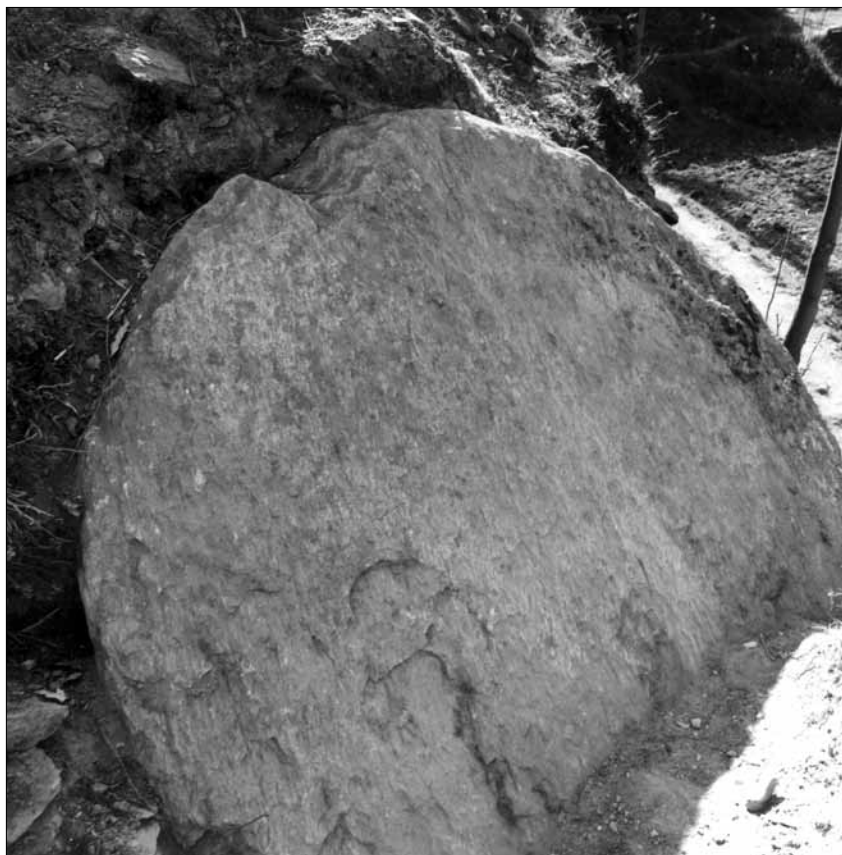

Fig. 87.
Arapkhanchina
(Shararai).
Stupa II. W
side; chattravali
disk, detail.
(Kuwayama 1993).

A. Stupas



Fig. 88. Arapkhanchina (Shararai). Stupa III. (De Marco 1982; Neg. CS).



Fig. 89. Arapkhanchina (Shararai). Stupa V. S side, general view. (Faccenna 1976; Neg. CS).



Fig. 90.
Arapkhanchina
(Shararai).
Stupa V. S side,
general view.
(De Marco
1982; Neg. CS).



Fig. 91.
Arapkhanchina
(Shararai).
Stupa V. E side
with stepped
inner structure.
(Kuwayama
1993).

A. Stupas



Fig. 92.
Arapkhanchina
(Shararai).
Stupa VI. W
side; general
view. (Nascari
1991; Neg. CS).



Fig. 93.
Arapkhanchina
(Shararai).
Stupa VI. N
side; parts of
the 3rd and
4th storey.
(Kuwayama
1993).



Fig. 94. Arapkhanchina (Shararai). Stupa VI. N side; parts of the facing remains of the 3rd and 4th storey, detail. (Faccenna 1976; Neg. CS).

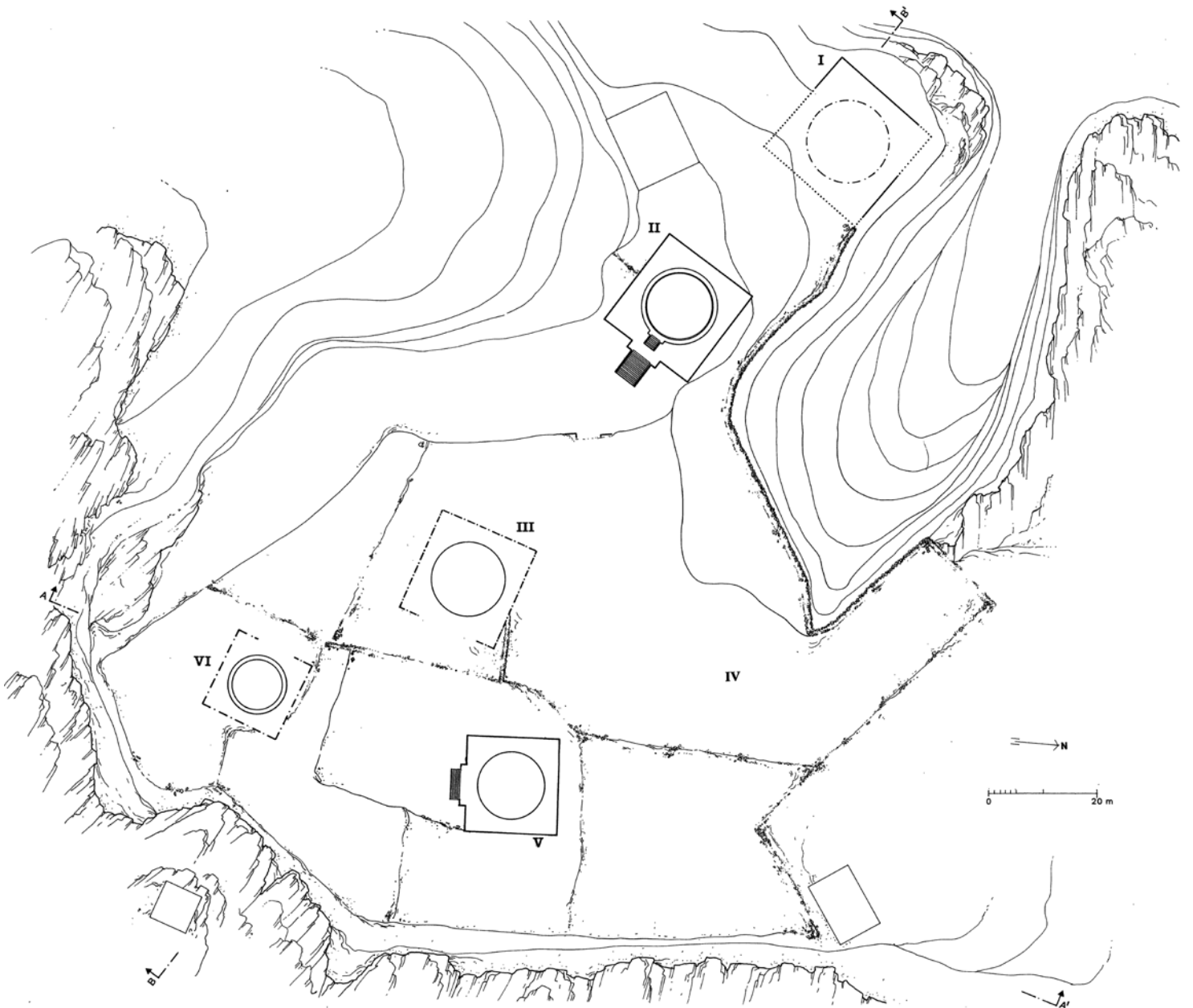

Fig. 95. Arapkhanchina (Shararai). Sacred area. General plan. Scale 1:400.
(Sabelli 1993; Martore 2004).

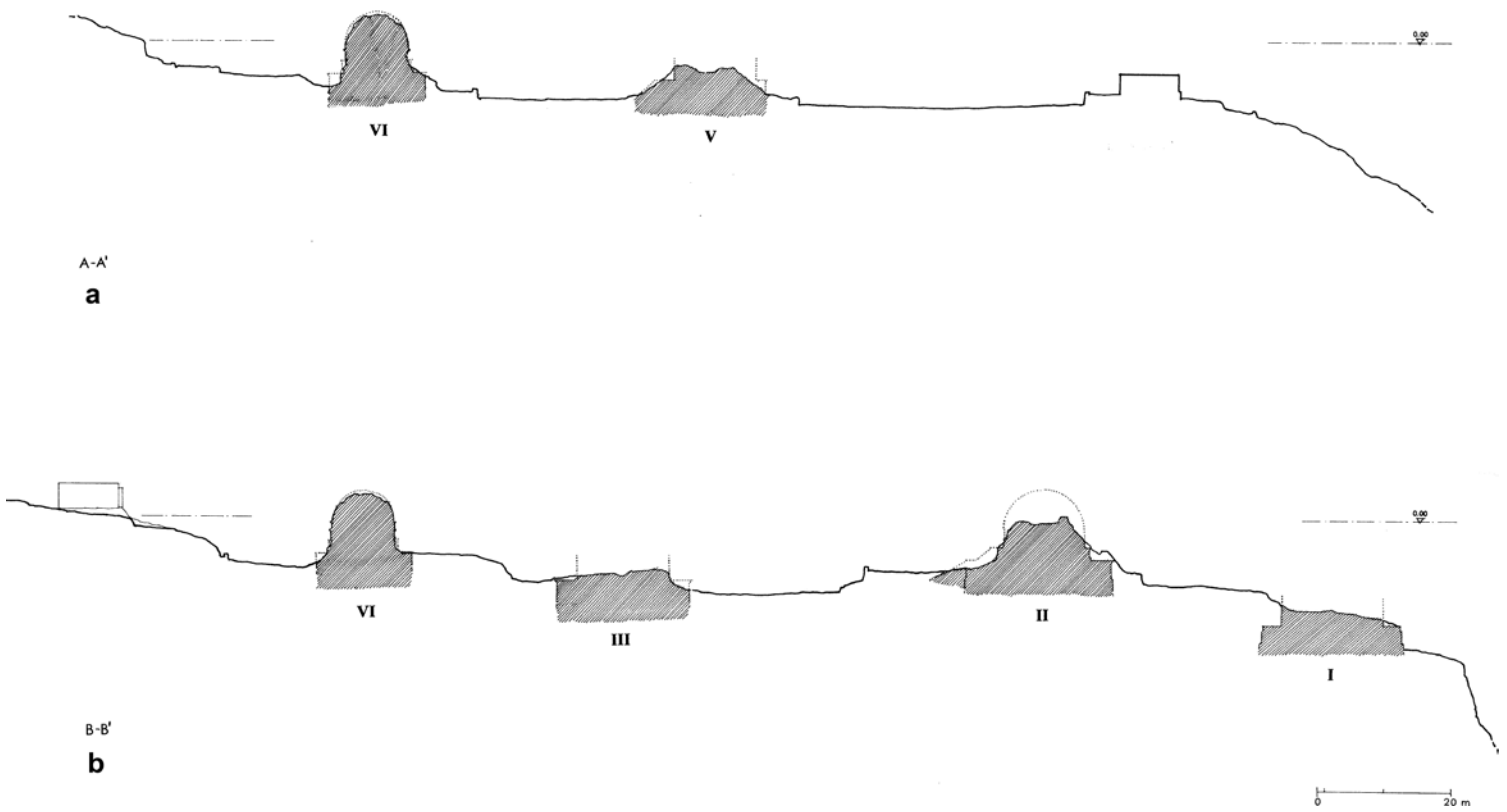

Fig. 96. Arapkhanchina (Shararai). Sacred area. *a.* A-A¹ general cross section. *b.* B-B¹ general cross section. Scale 1:400. (Sabelli 1993; Martore 2004).

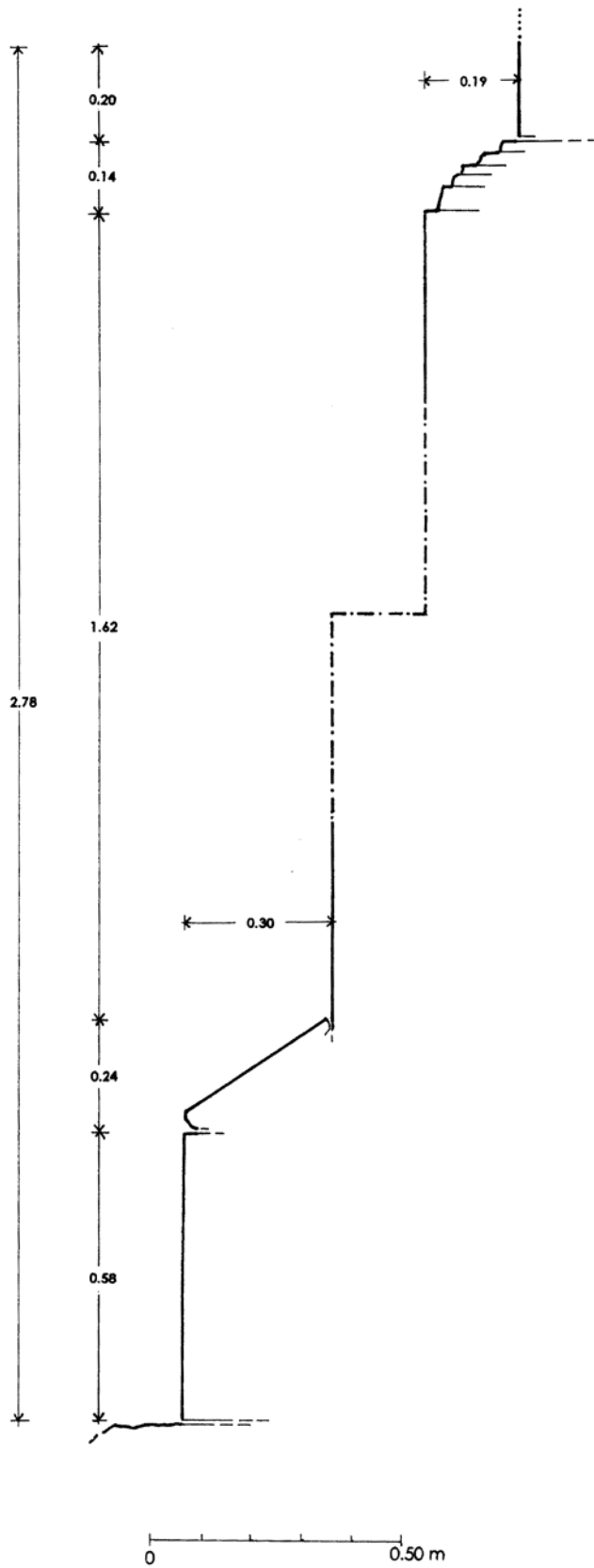

Fig. 97. Arapkanchina (Shararai). Stupa I. 1st storey, S side (upper part), N side (lower part). Scale 1:10. (Sabelli 1993; Martore 2004).

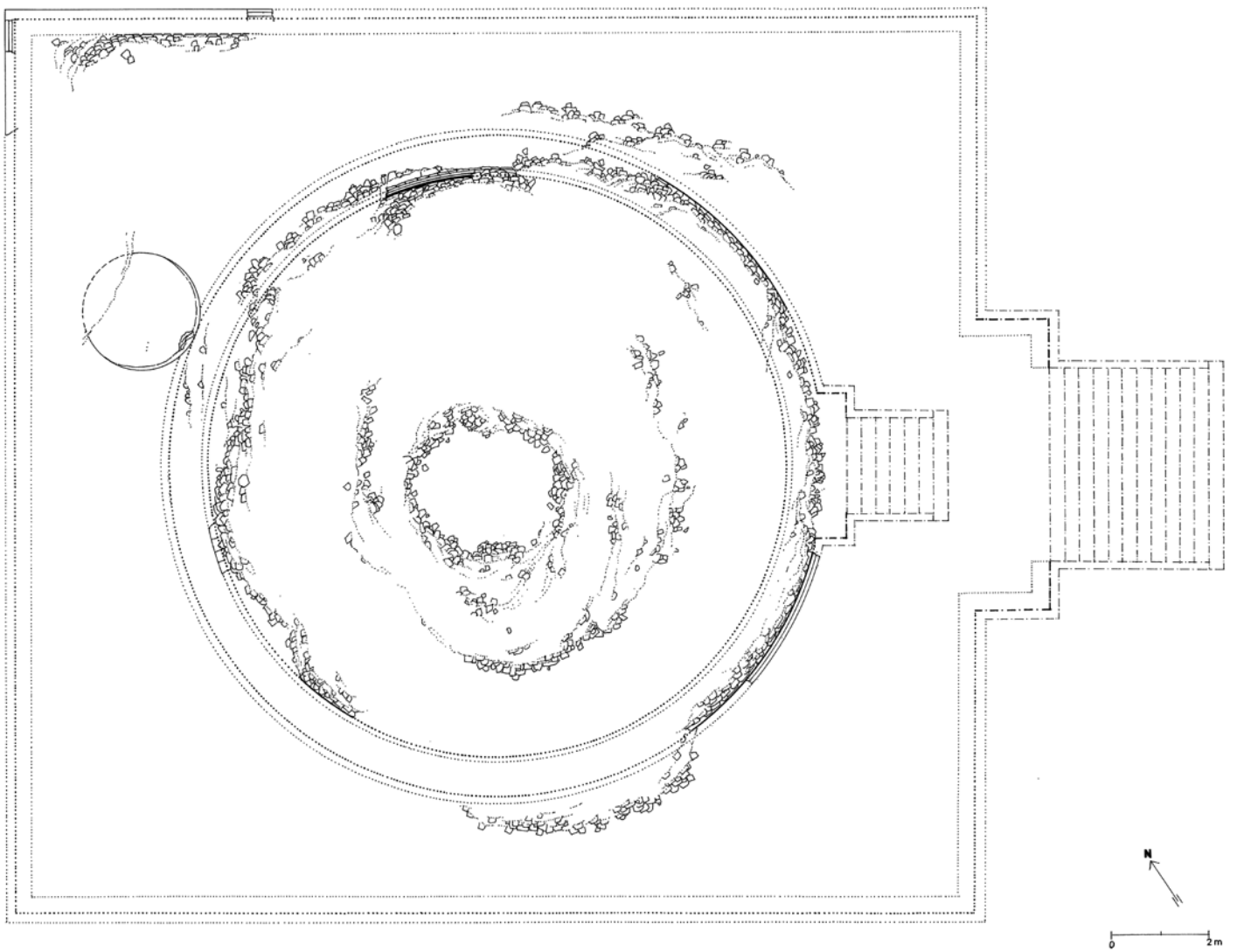

Fig. 98. Arapkhanchina (Shararai). Stupa II. Plan. (Sabelli 1993; Martore 2004).

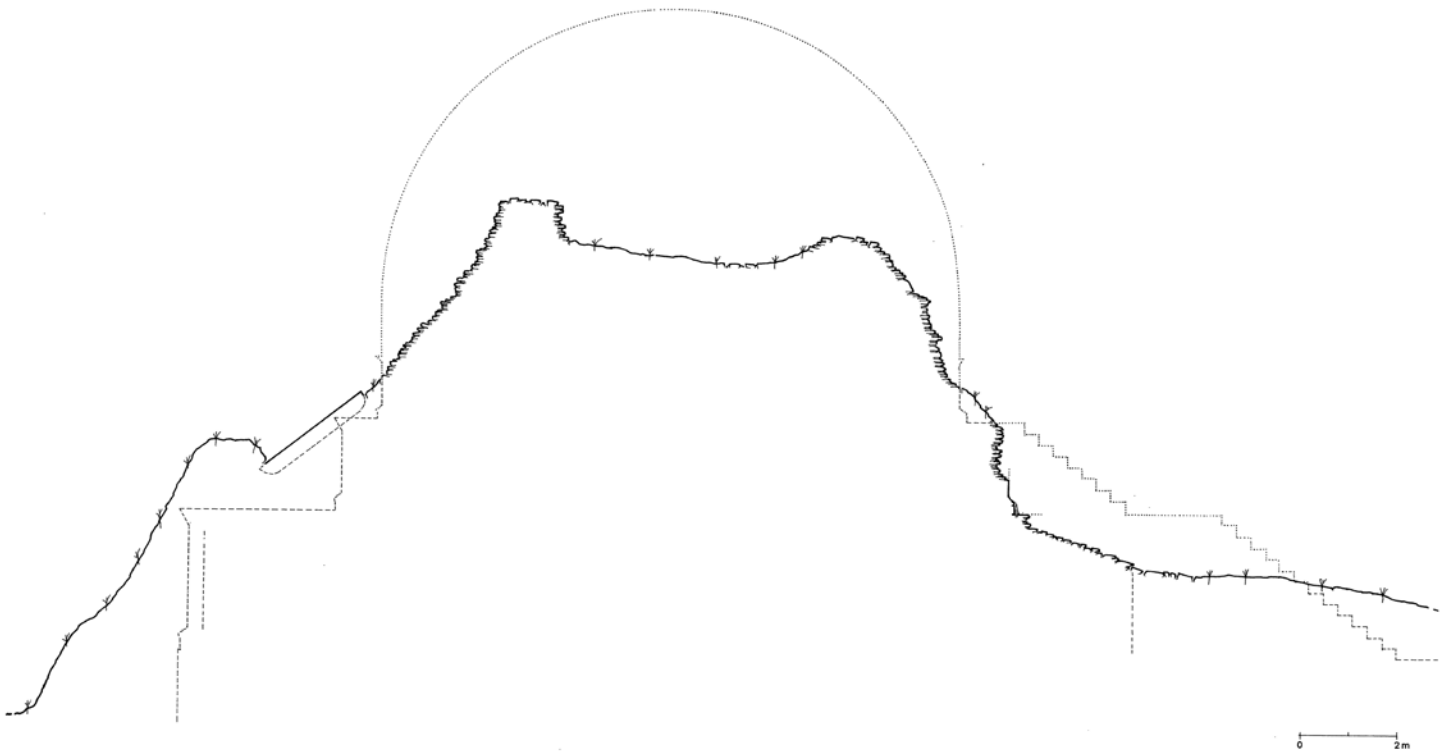

Fig. 99. Arapkanchina (Shararai). Stupa II. E-W cross section. (Sabelli 1993; Martore 2004).

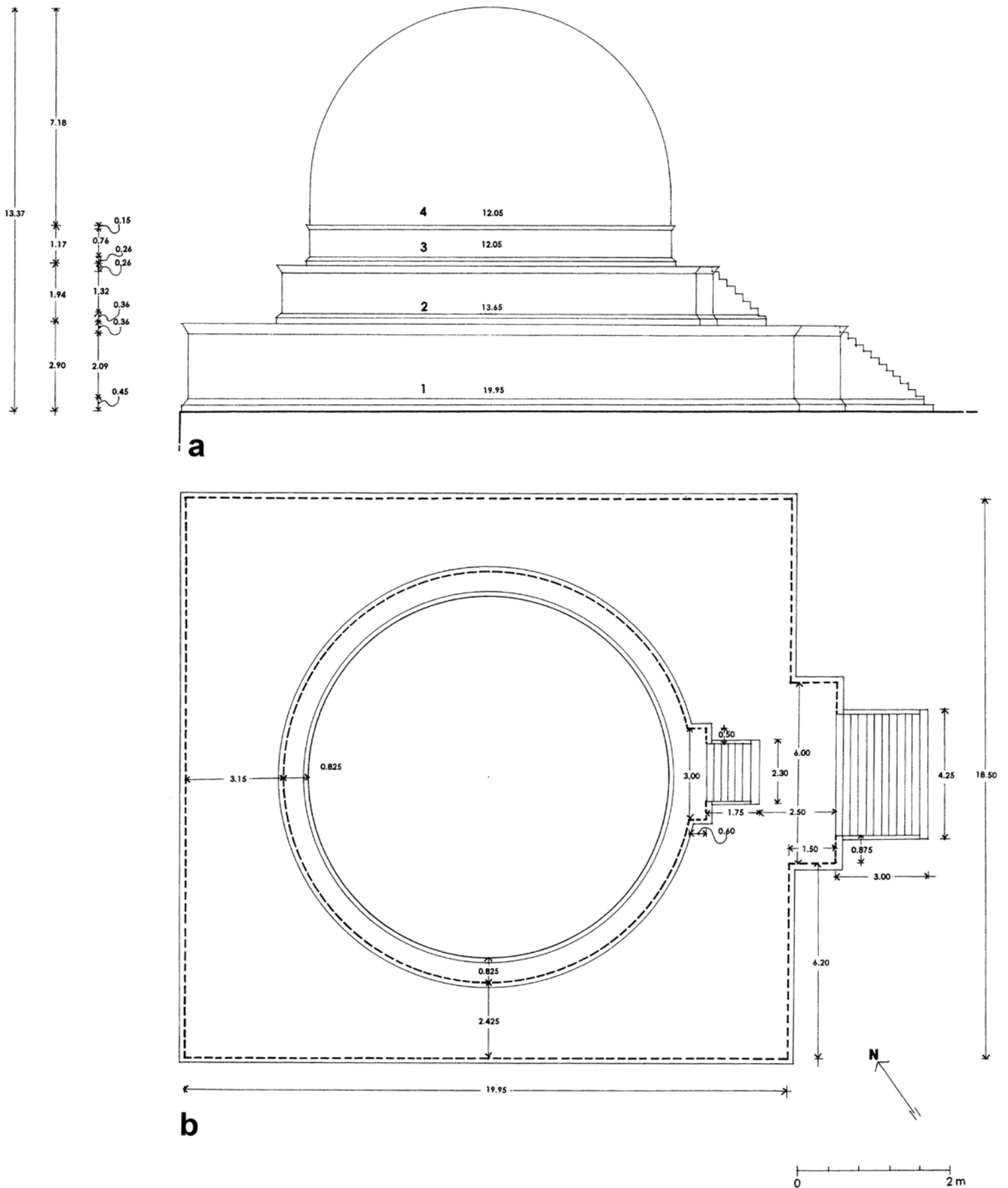

Fig. 100. Arapkhanchina (Shararai). Stupa II. *a*. Sketch elevation showing the measures. *b*. Sketch plan showing the measures. (Martore 2004).

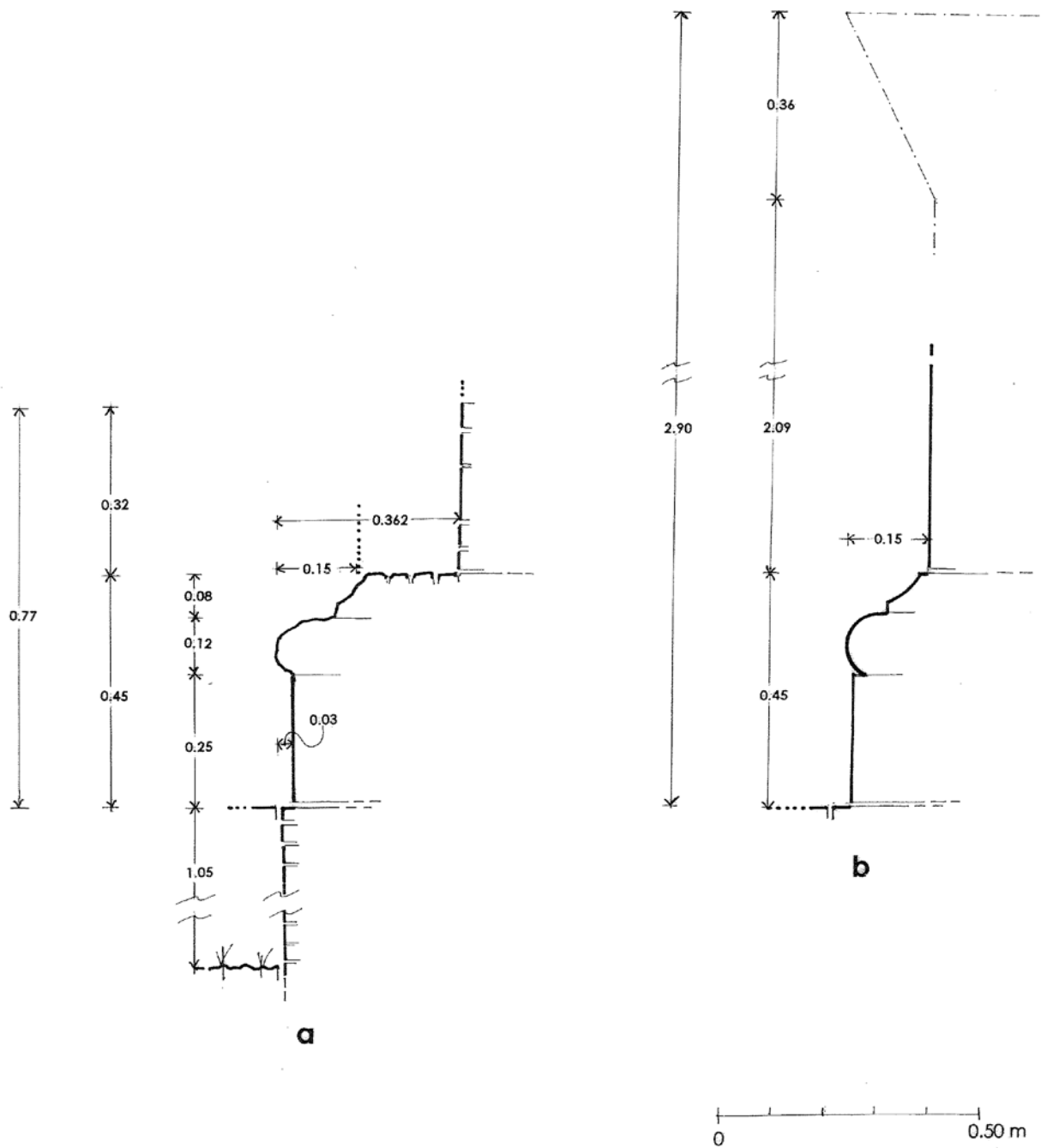

Fig. 101. Arapkanchina (Shararai). Stupa II. 1st storey. *a.* profile. *b.* reconstructed profile, with plaster. (Sabelli 1993; Martore 2004).

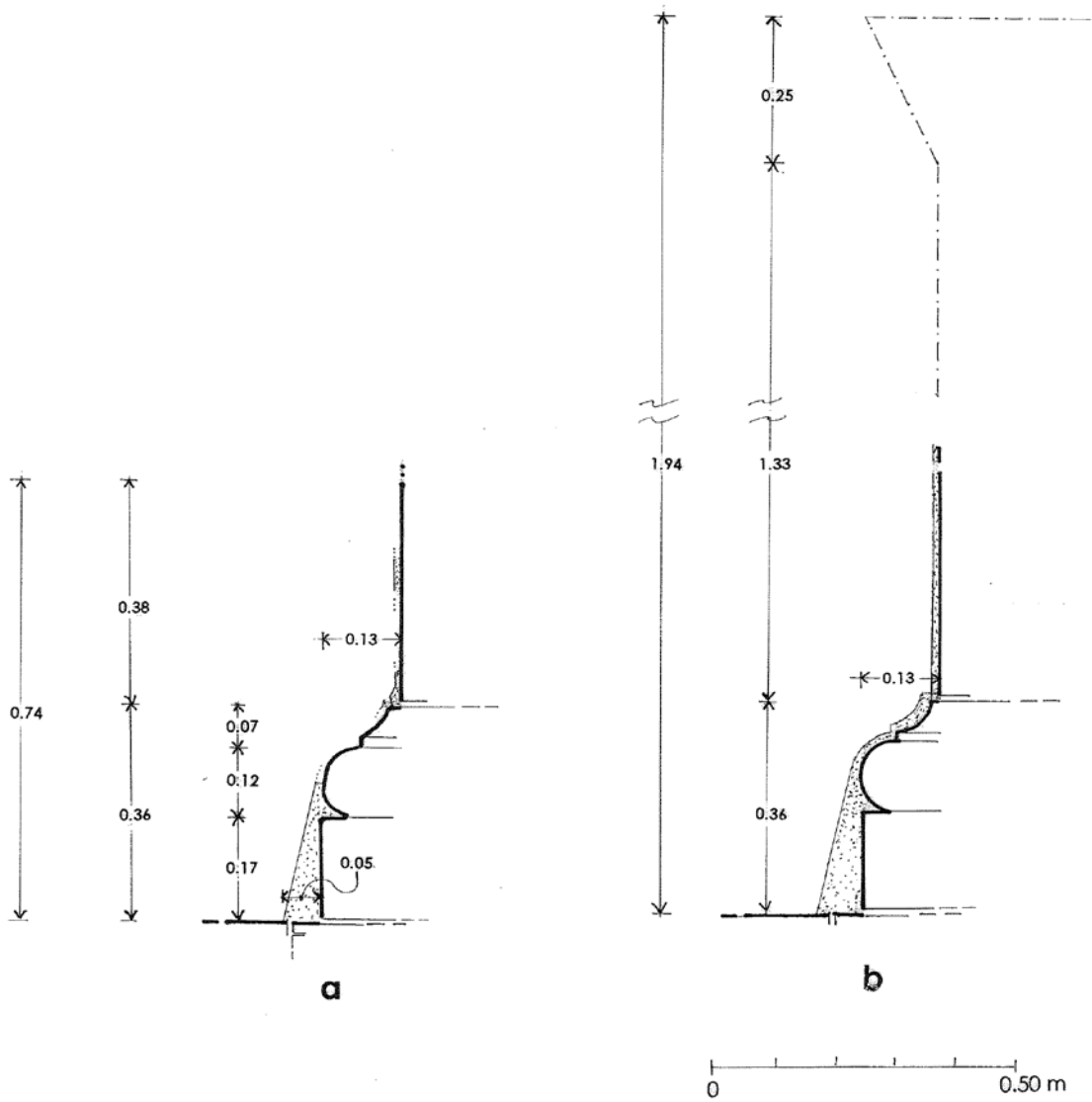

Fig. 102. Arapkhanchina (Shararai). Stupa II. 2nd storey. *a.* profile. *b.* reconstructed profile, with plaster. (Sabelli 1993; Martore 2004).

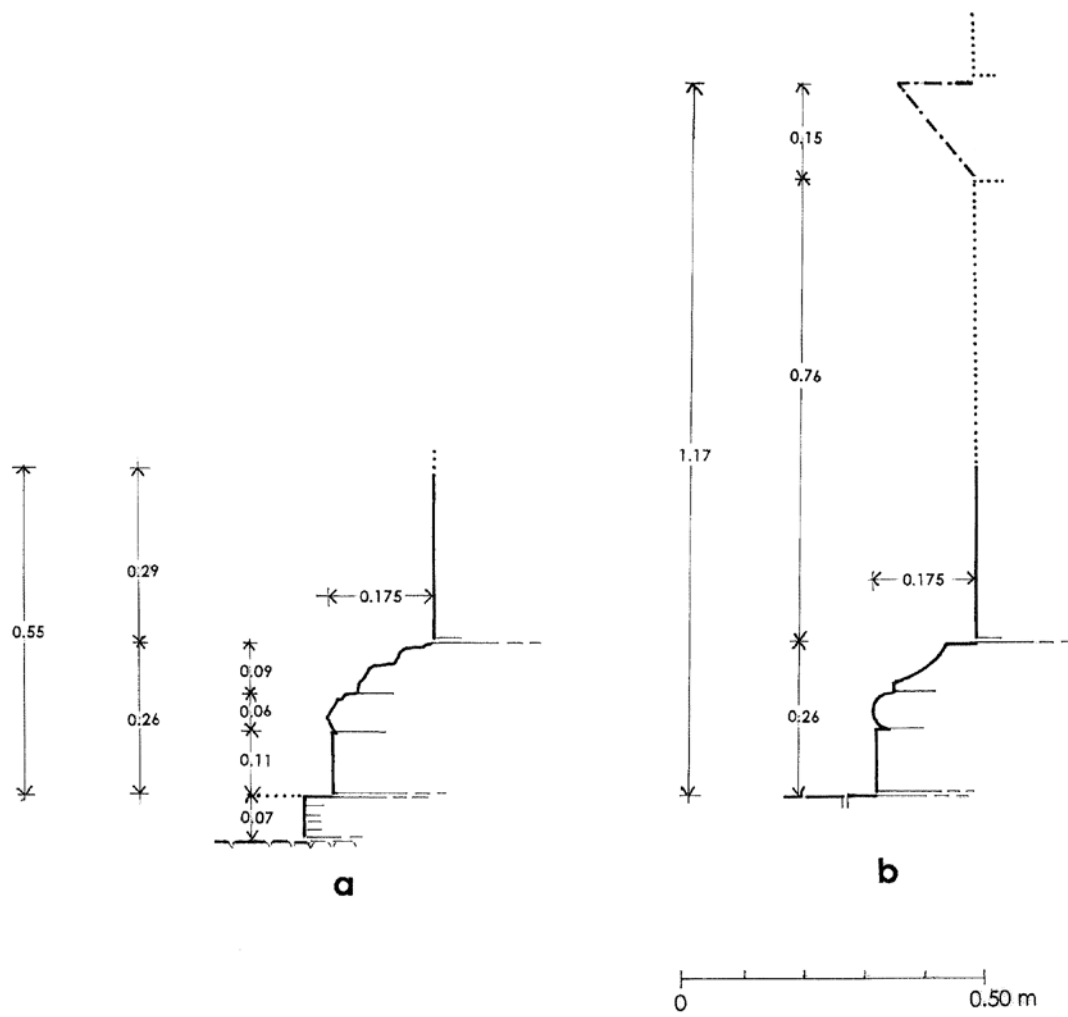

Fig. 103. Arapkhanchina (Shararai). Stupa II. 3rd storey. *a.* profile. *b.* reconstructed profile, with plaster. (Sabelli 1993; Martore 2004).

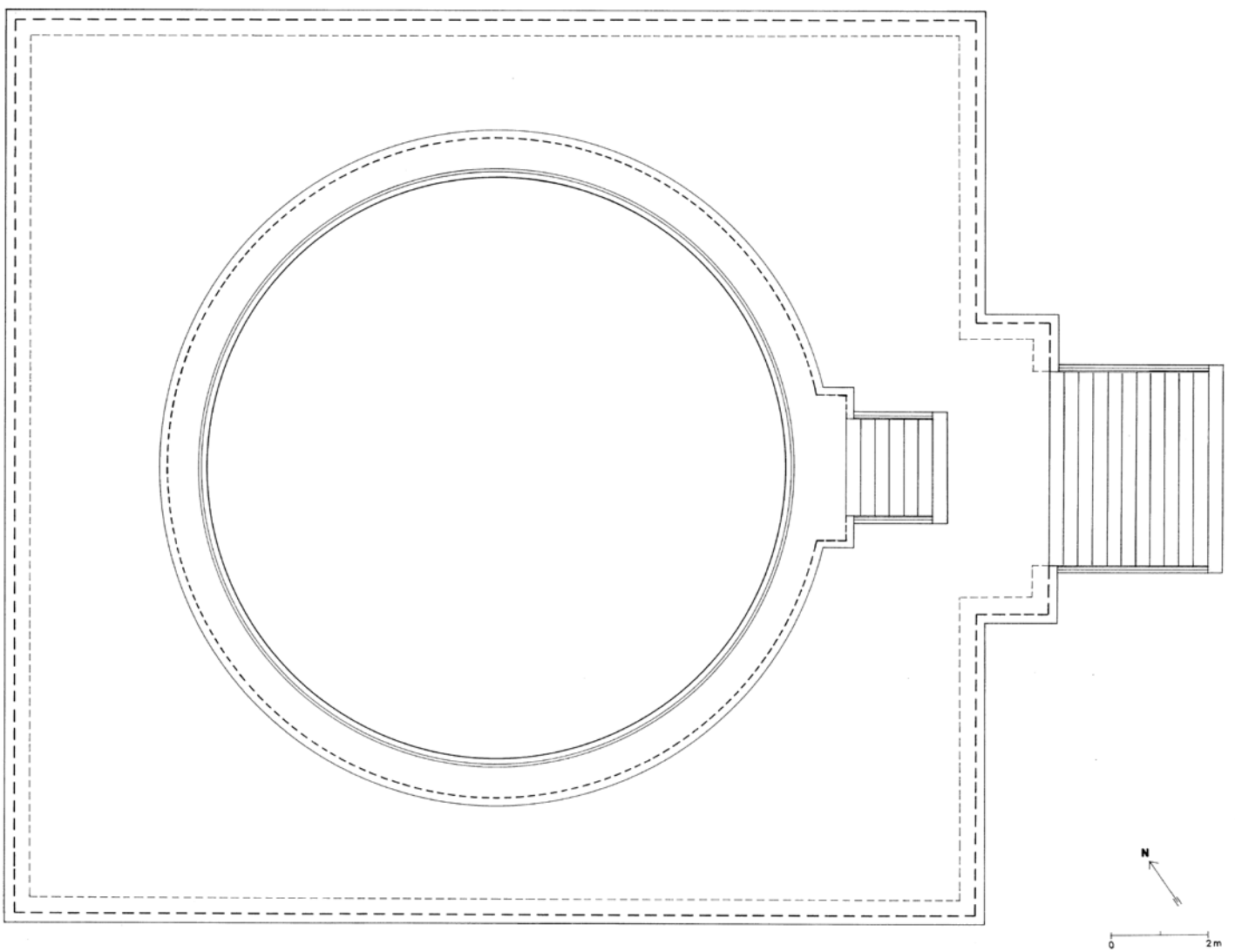

Fig. 104. Arapkhanchina (Shararai). Stupa II. Reconstructed plan.
(Sabelli 1993; Martore 2004).

A. Stupas

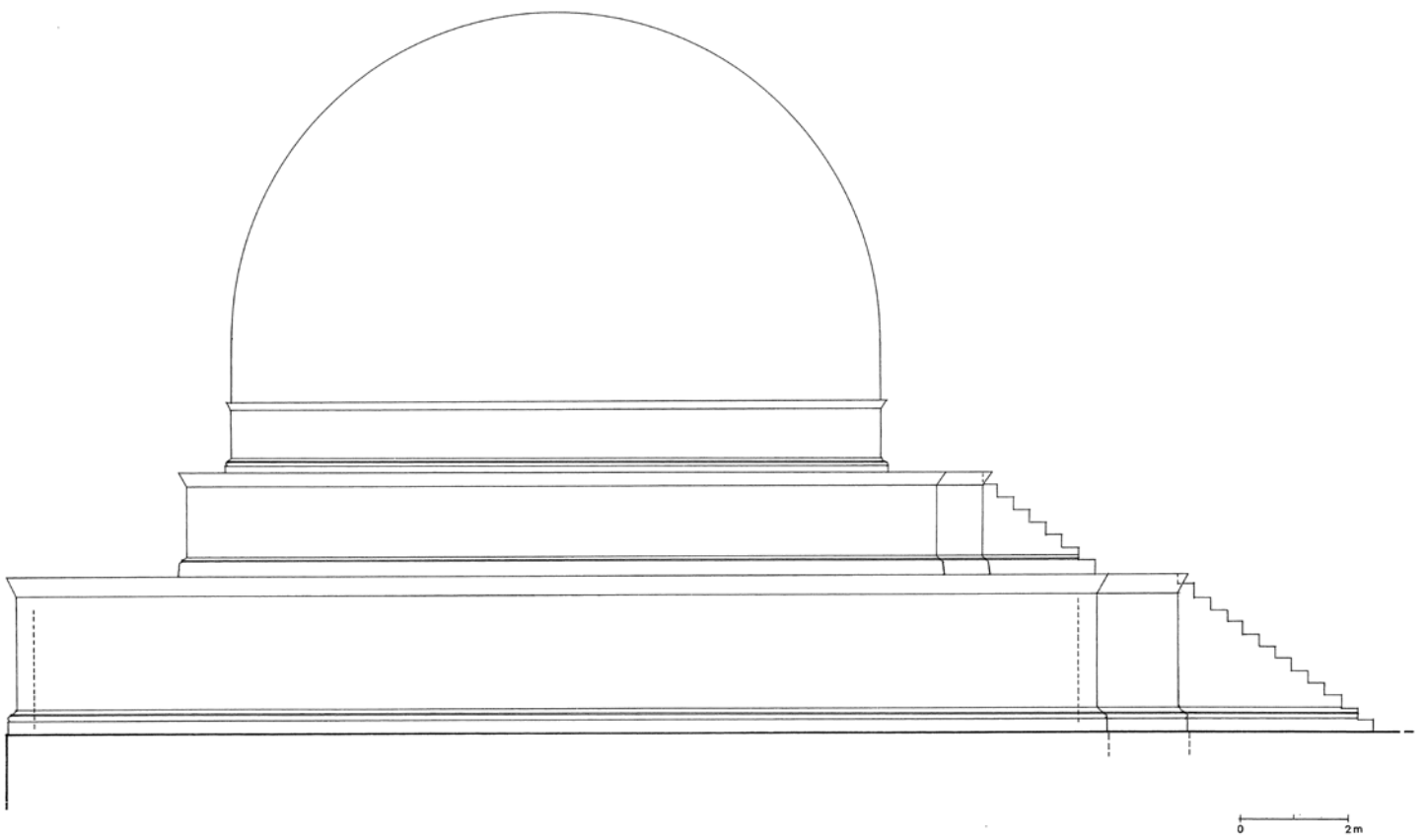

Fig. 105. Arapkhanchina (Shararai). Stupa II. Reconstructed elevation.
(Sabelli 1993; Martore 2004).

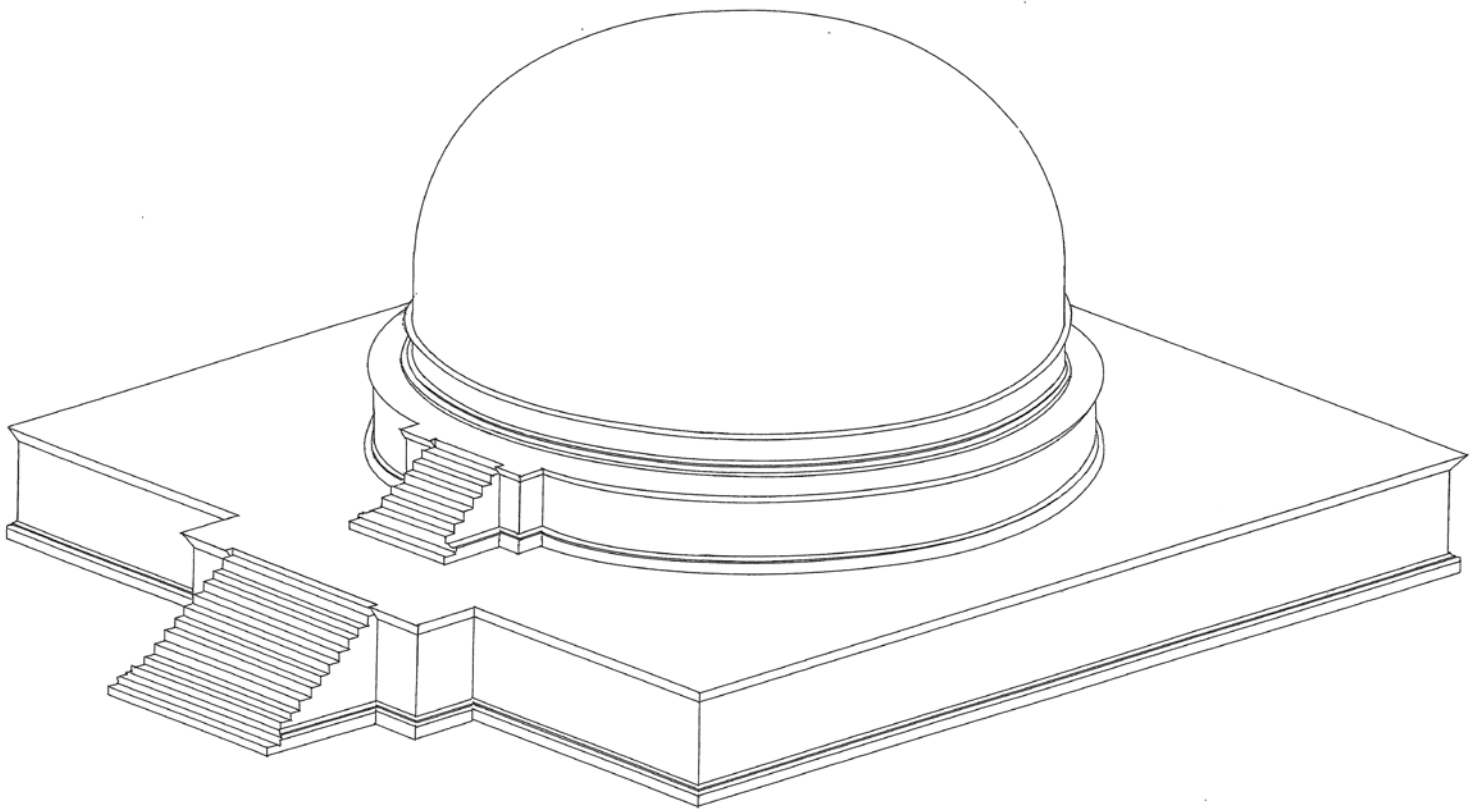

Fig. 106. Arapkhanchina (Shararai). Stupa II. Axonometric view. (Martore 2004).

A. Stupas

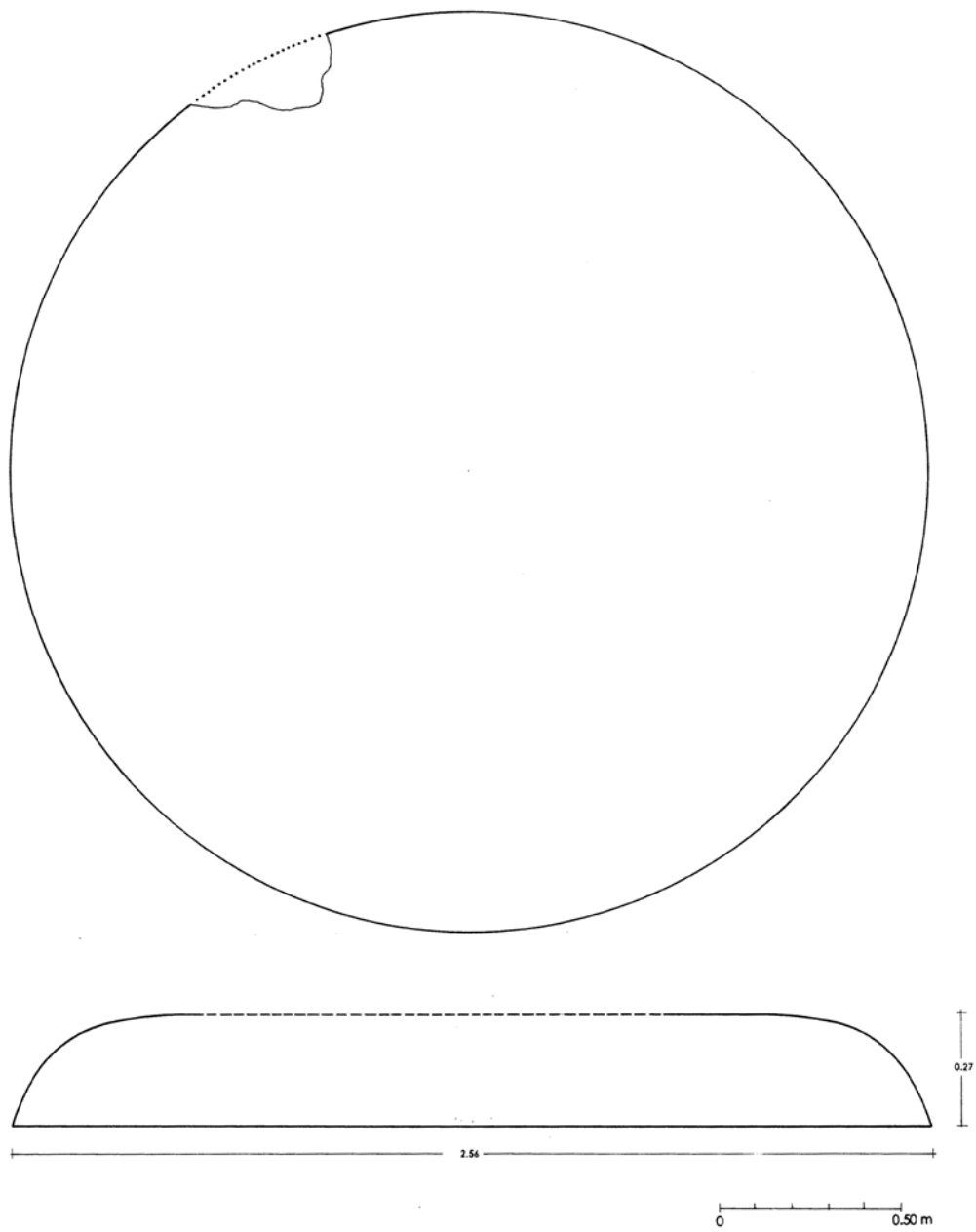

Fig. 107. Arapkhanchina (Shararai). Stupa II. Disk. (Sabelli 1993; Martore 2004).

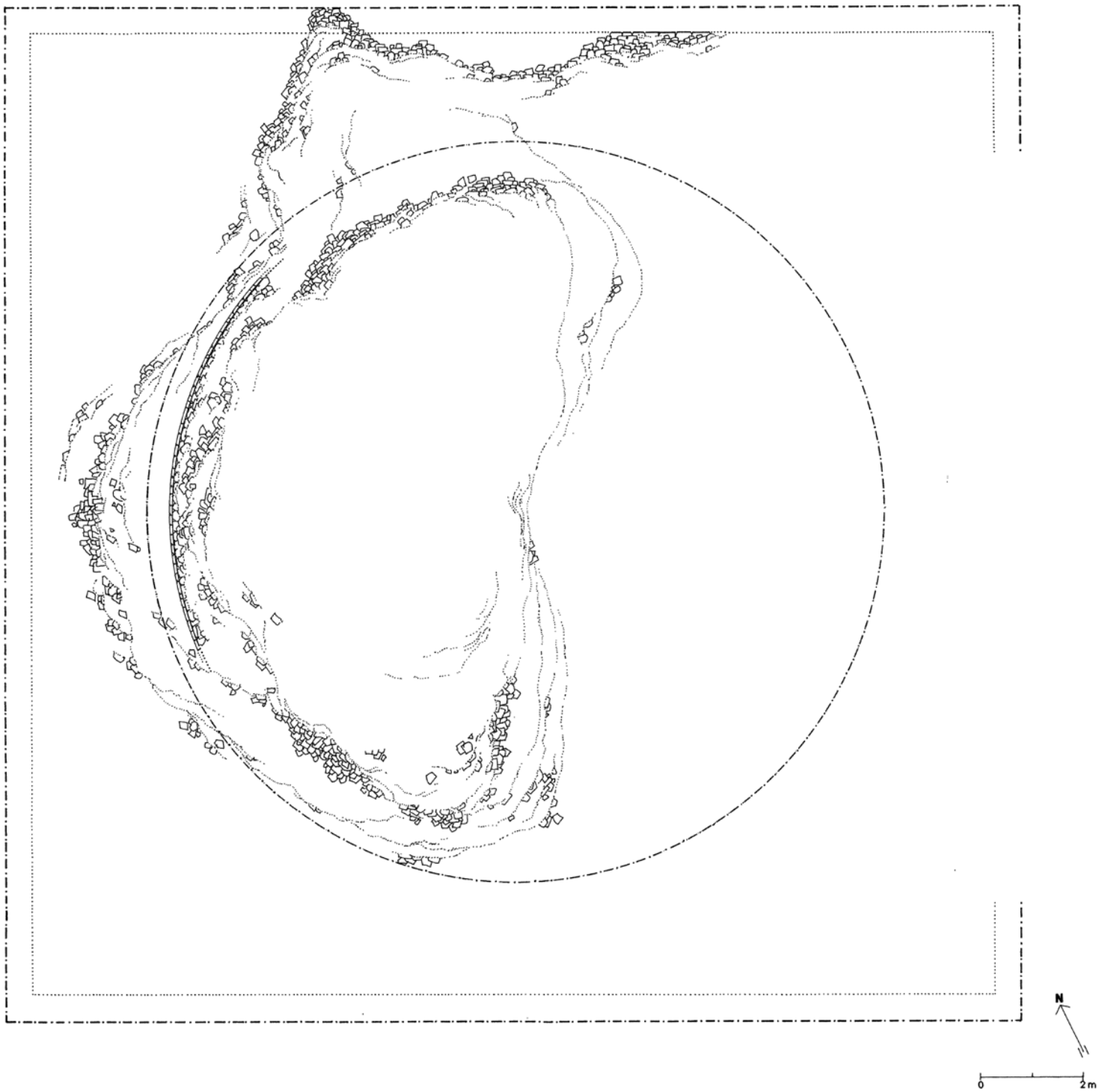

Fig. 108. Arapkhanchina (Shararai). Stupa III. Plan. (Sabelli 1993; Martore 2004).

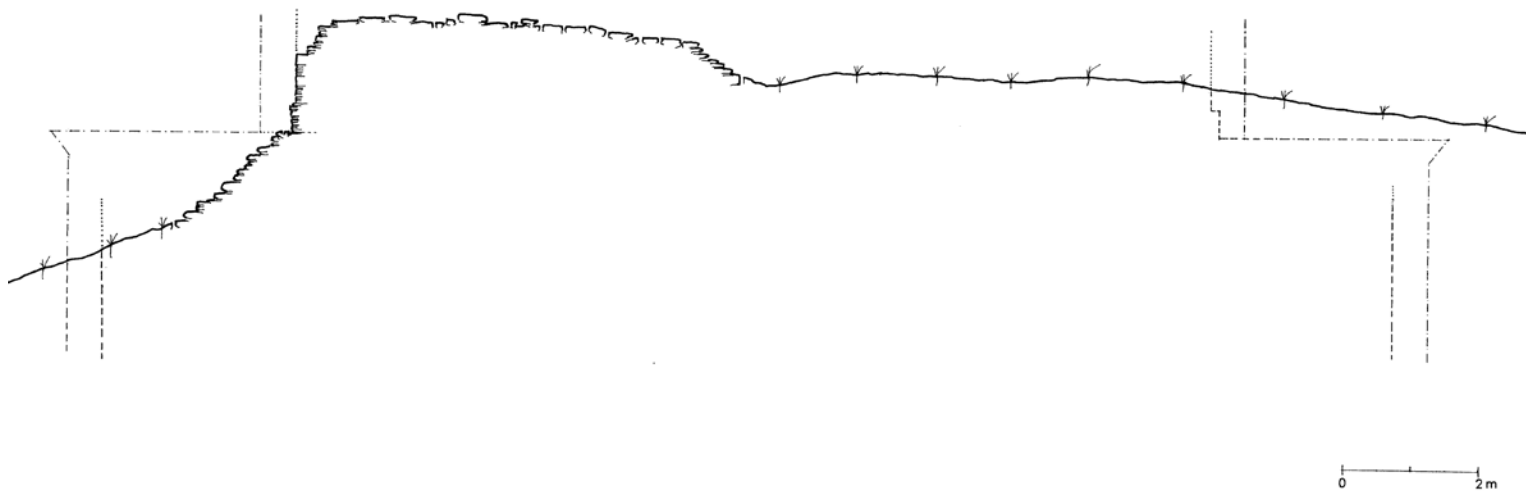

Fig. 109. Arapkanchina (Shararai). Stupa III. E-W cross section. (Sabelli 1993; Martore 2004).

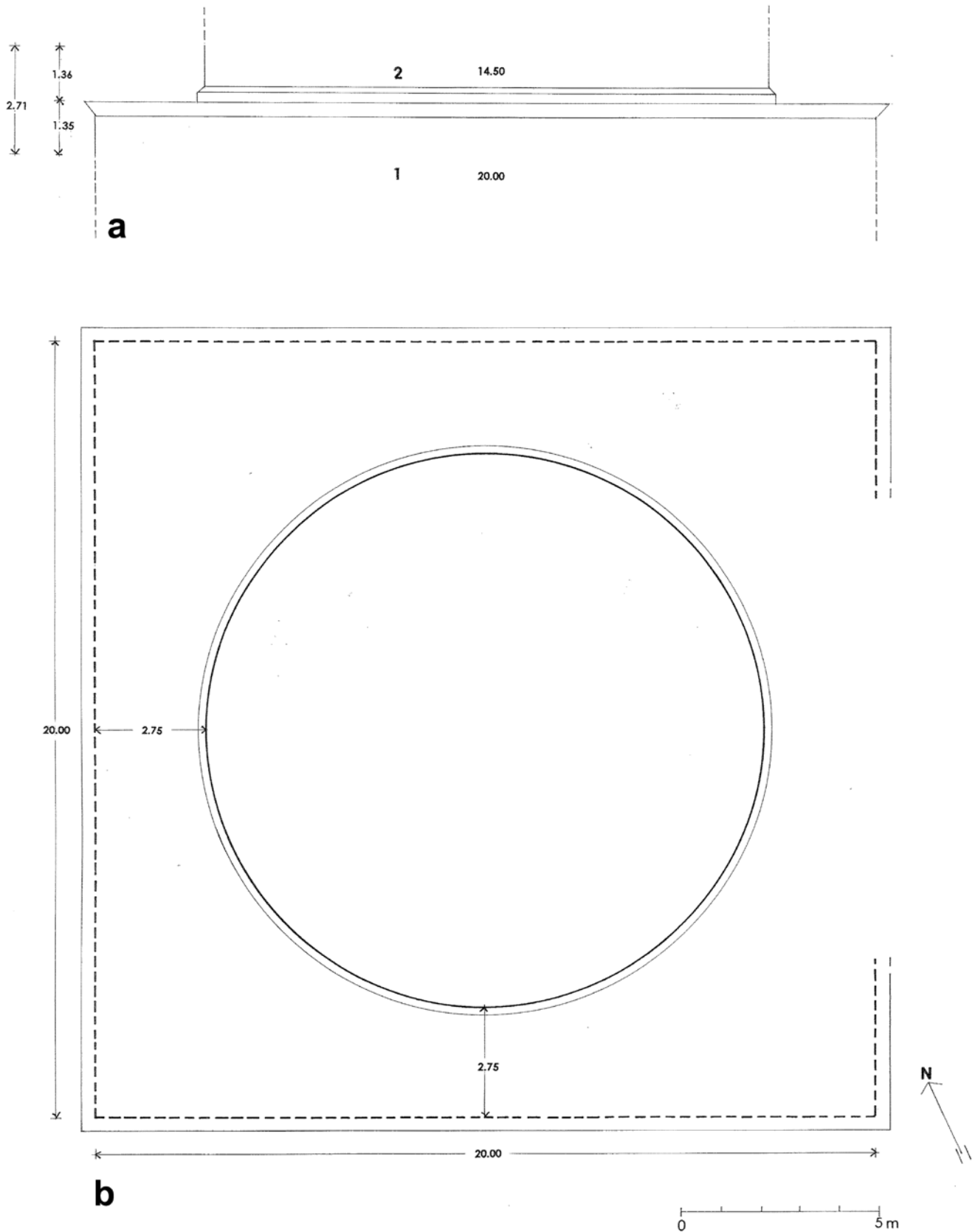

Fig. 110. Arapkhanchina (Shararai). Stupa III. *a.* sketch elevation showing the measures. *b.* sketch plan showing the measures. (Martore 2004).

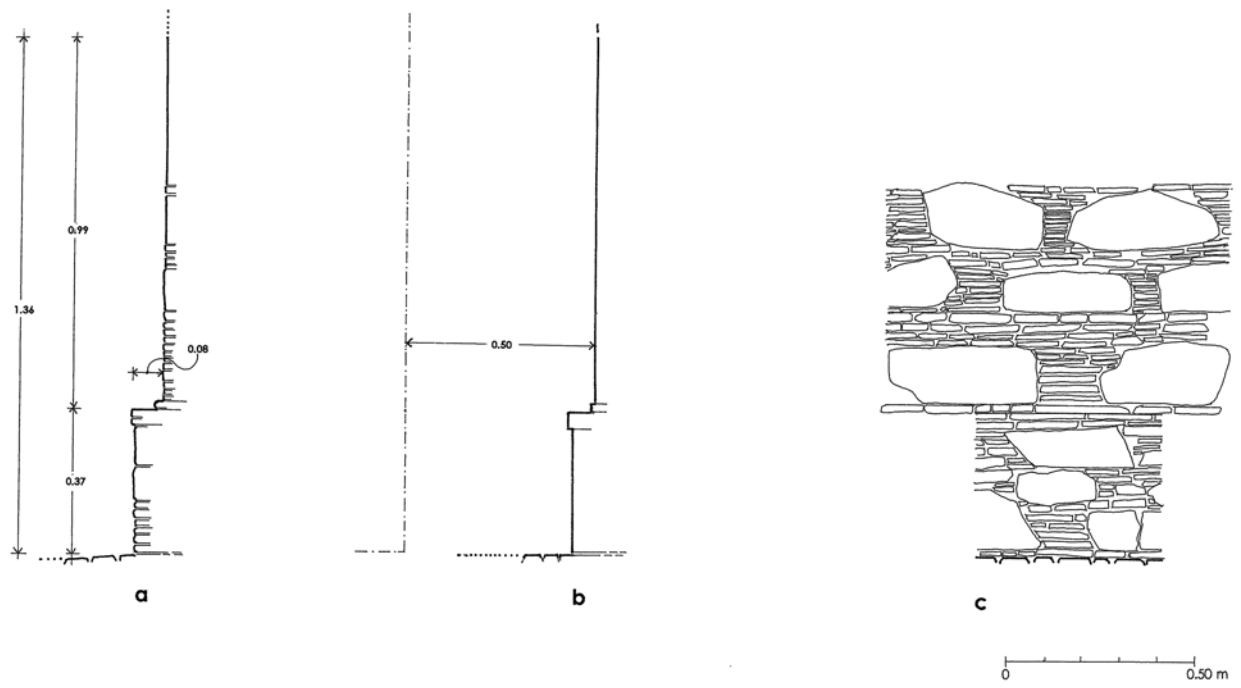

Fig. 111. Arapkhanchina (Shararai). Stupa III. 2nd storey. *a.* profile. *b.* reconstructed profile. *c.* elevation with masonry technique, detail. (Sabelli 1993; Martore 2004).

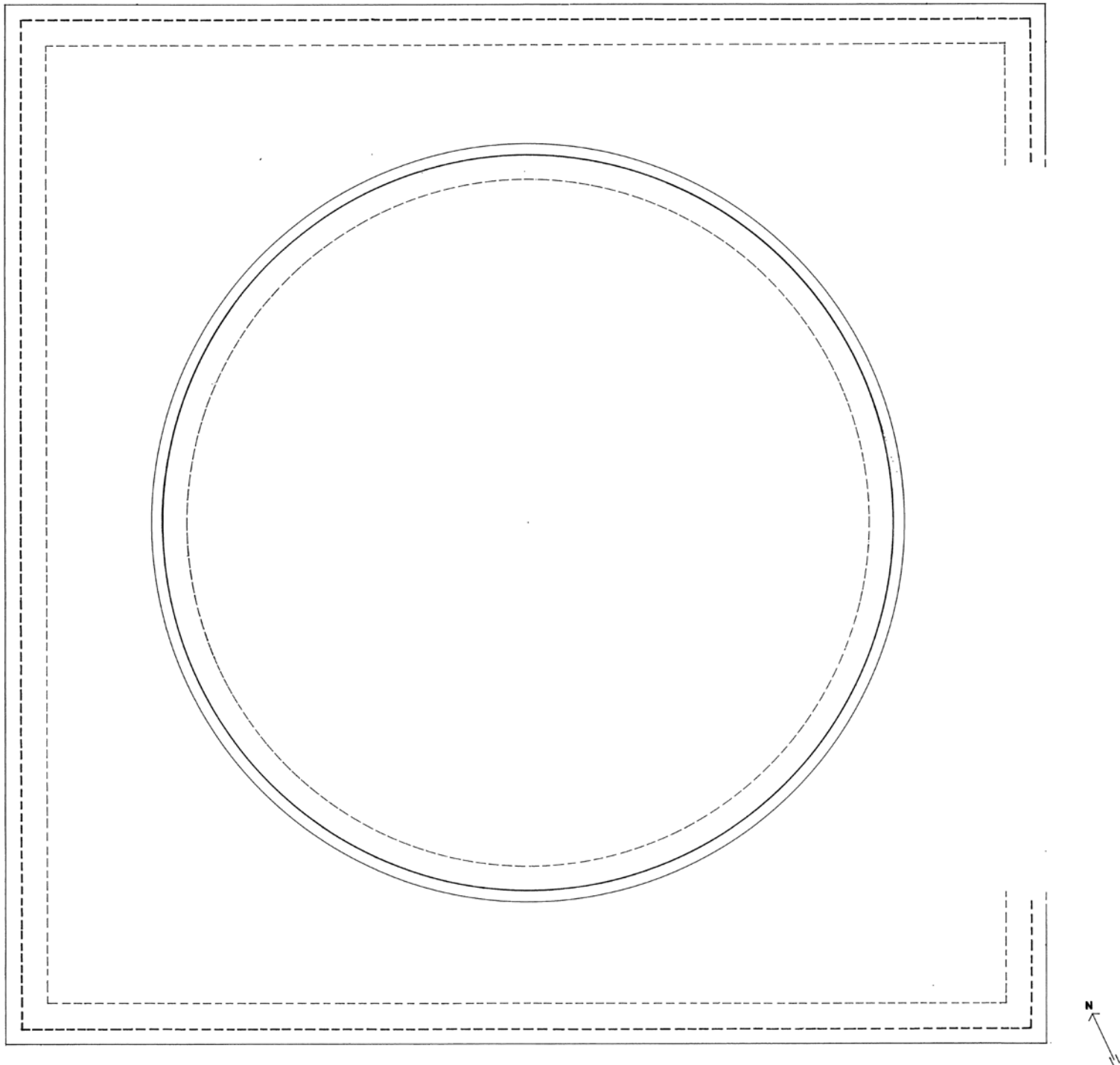

Fig. 112. Arapkhanchina (Shararai). Stupa III. 1st and 2nd storey. Plan, hypothetical reconstruction. (Sabelli 1993; Martore 2004).

A. Stupas

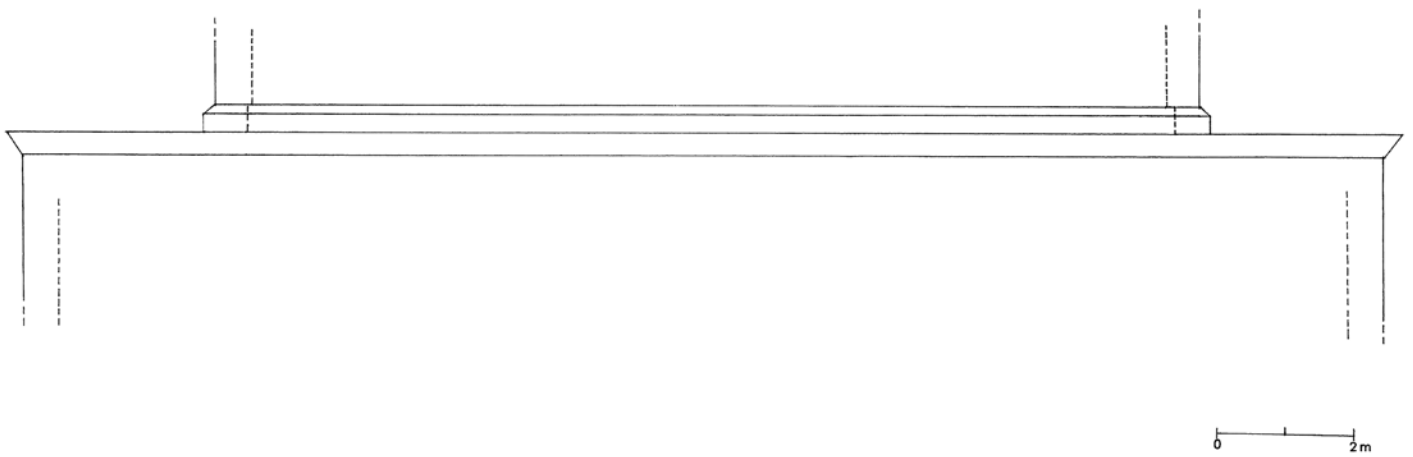

Fig. 113. Arapkhanchina (Shararai). Stupa III. 1st and 2nd storey. Elevation, hypothetical reconstruction. (Sabelli 1993; Martore 2004).

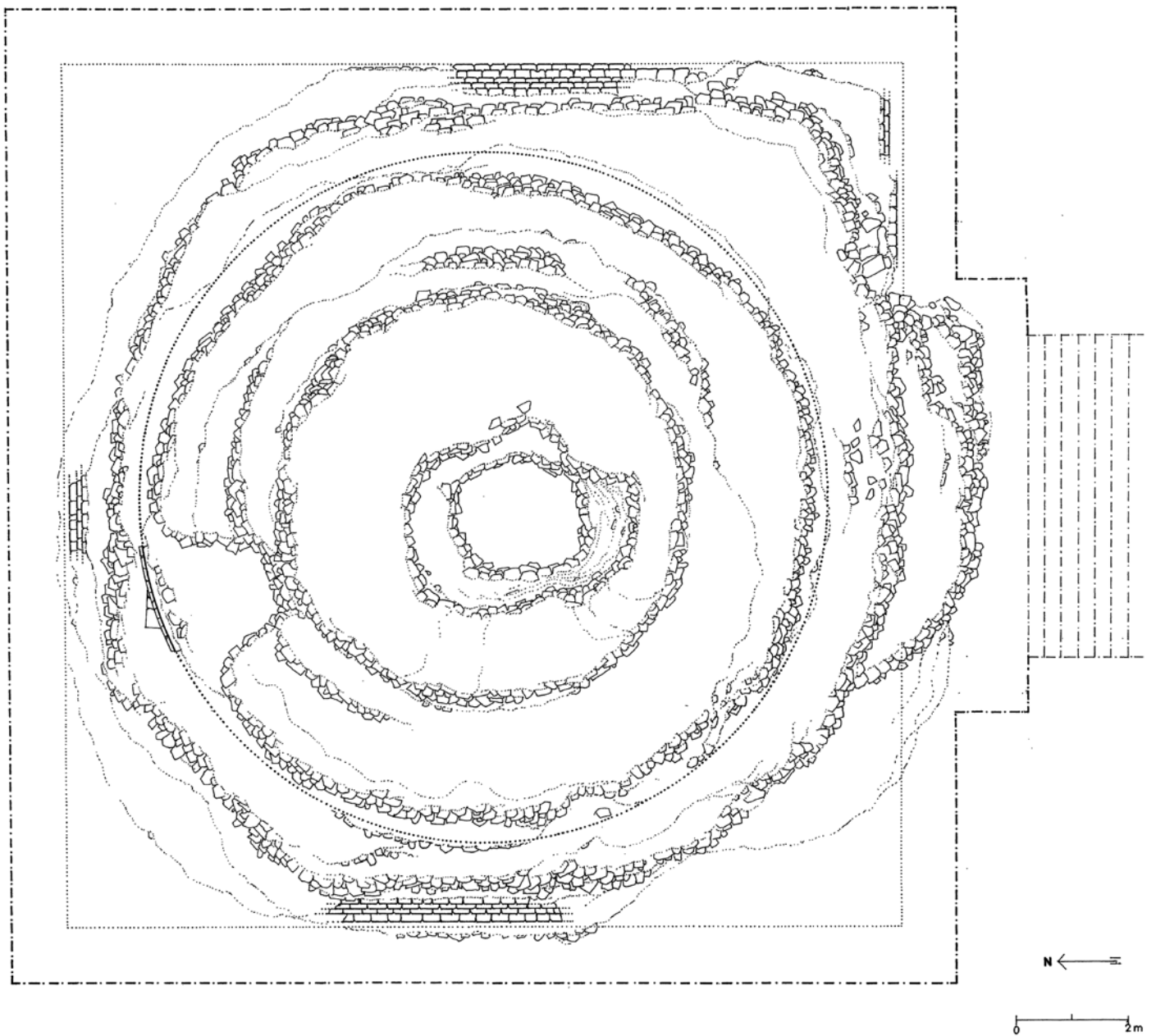

Fig. 114. Arapkhanchina (Shararai). Stupa V. Plan. (Sabelli 1993; Martore 2004).

A. Stupas



Fig. 115. Arapkanchina (Shararai). Stupa V. N-S cross section. (Sabelli 1993; Martore 2004).

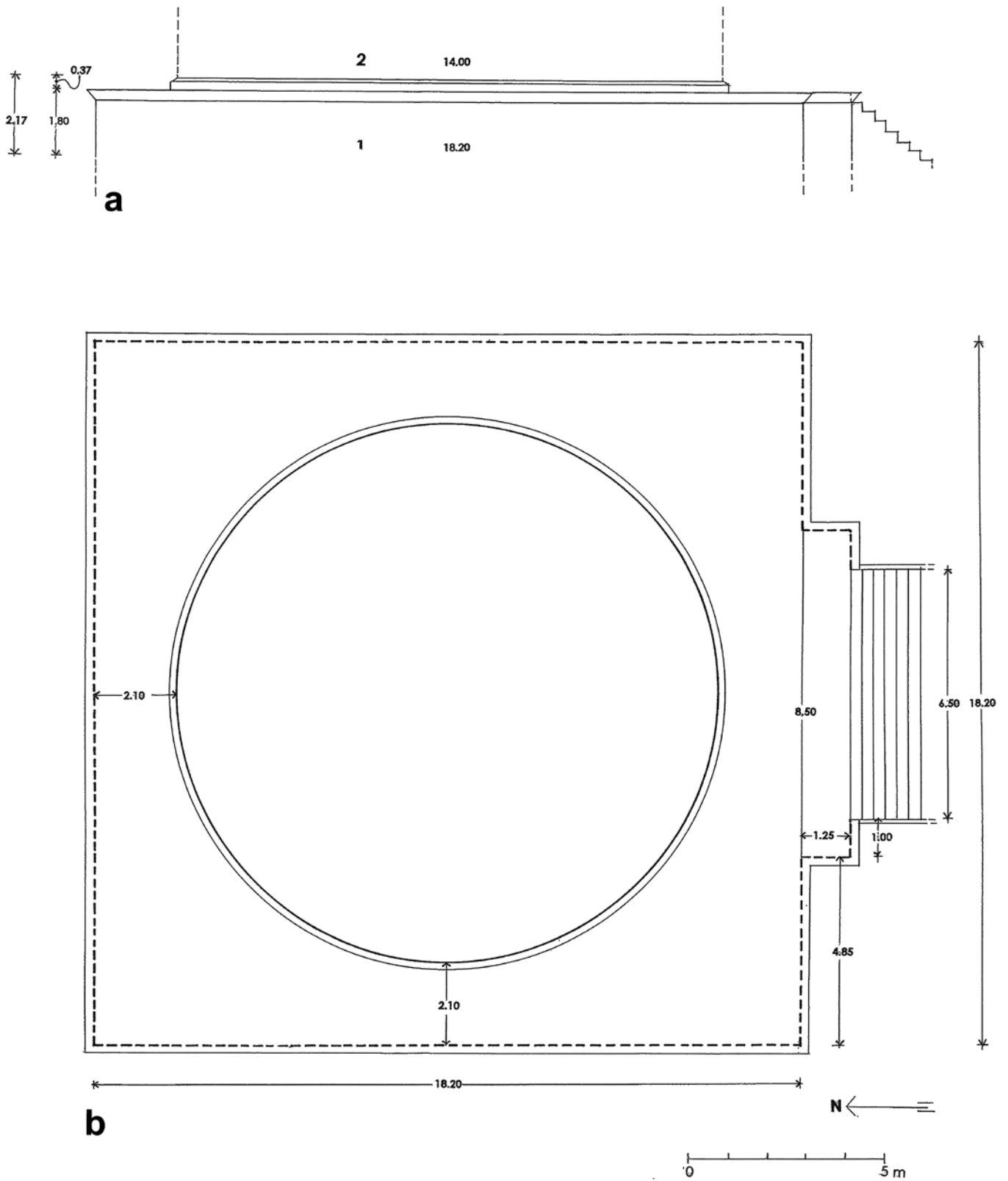

Fig. 116. Arapkhanchina (Shararai). Stupa V. *a.* Sketch elevation showing the measures. *b.* Sketch plan showing the measures. (Martore 2004).

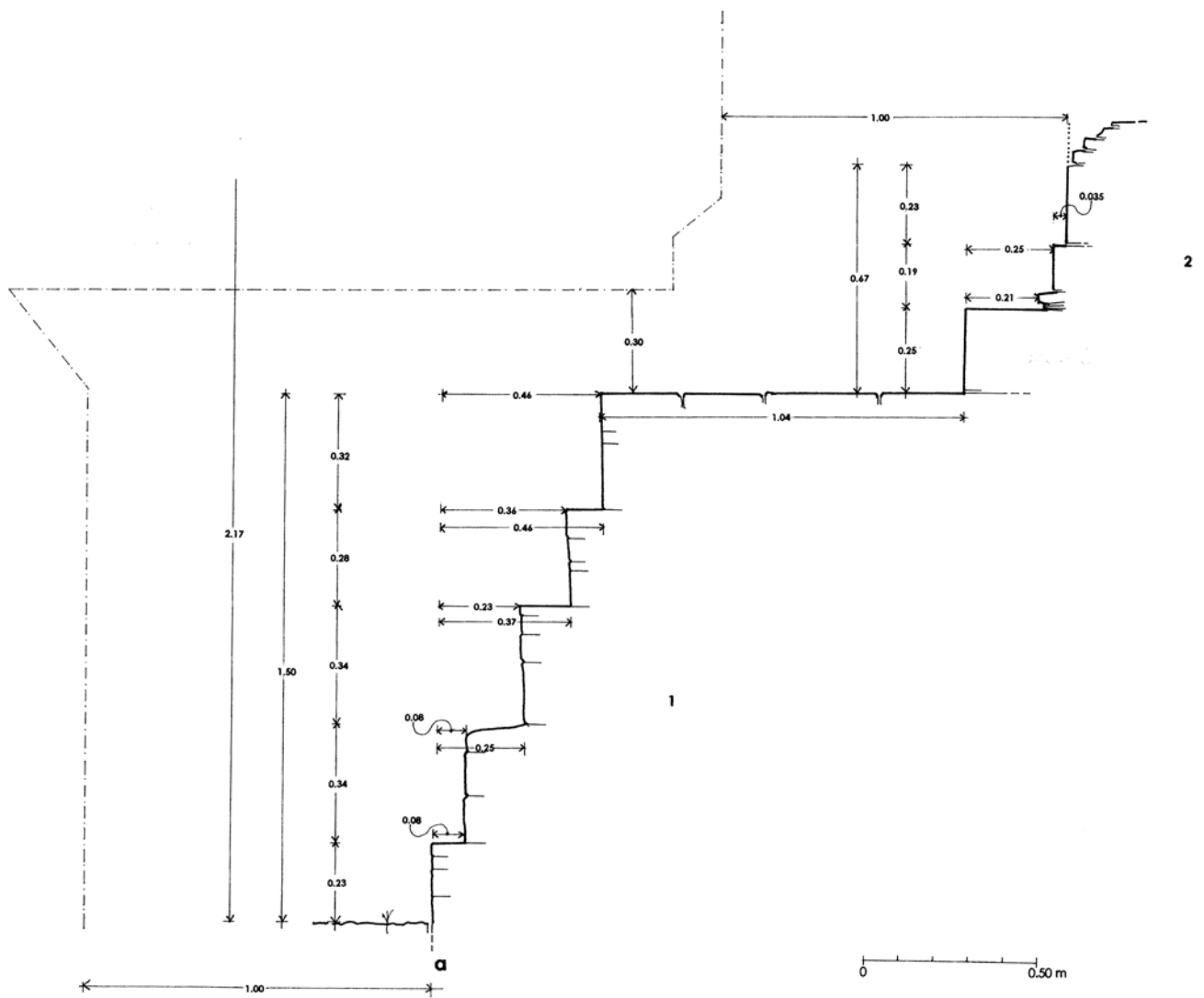

Fig. 117. Arapkhanchina (Shararai). Stupa V. 1st storey (E side), 2nd storey (N side). Construction system. (Sabelli 1993; Martore 2004).

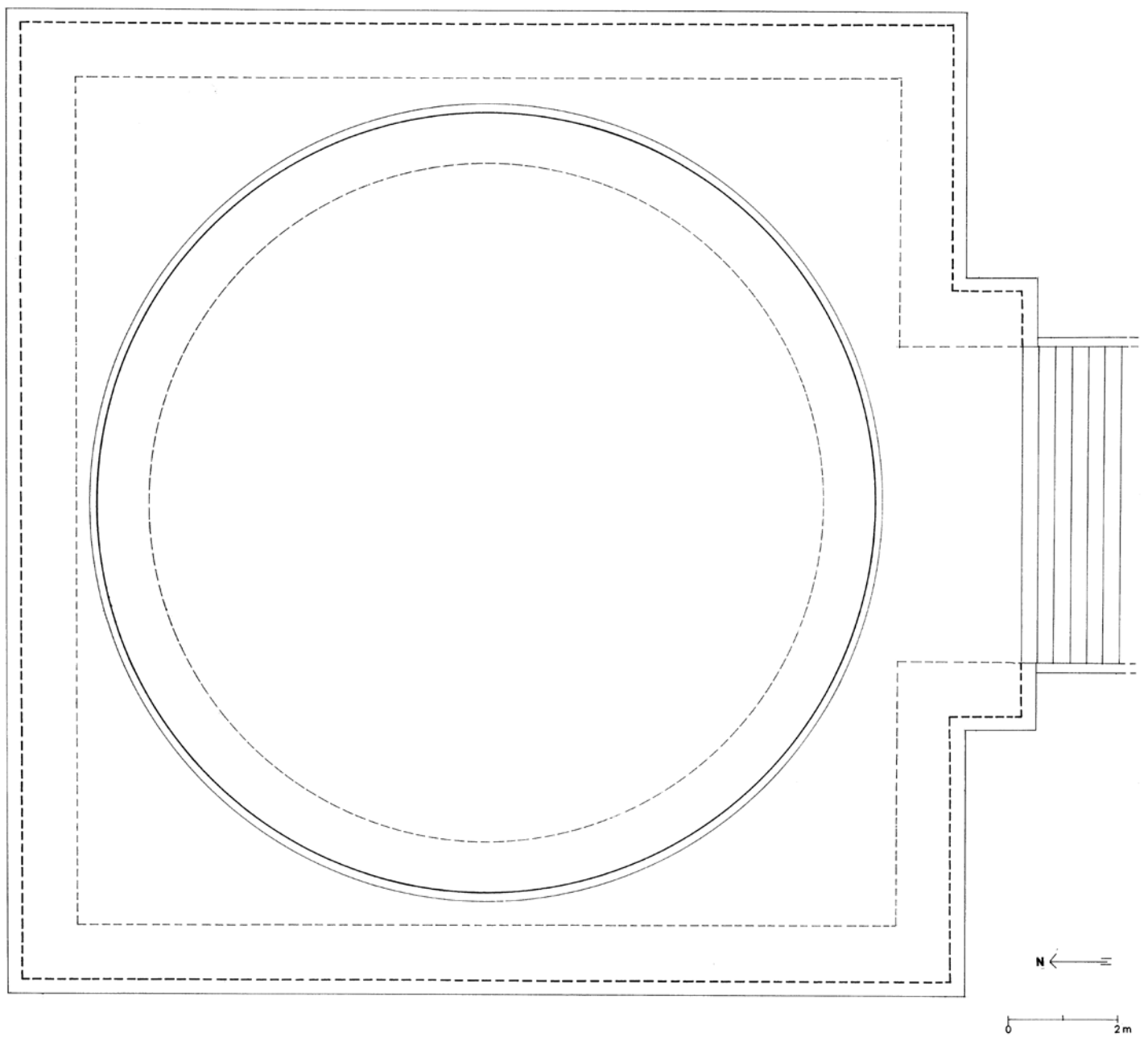

Fig. 118. Arapkhanchina (Shararai). Stupa V. Plan, hypothetical reconstruction of the 1st and 2nd storey. (Martore 2004).

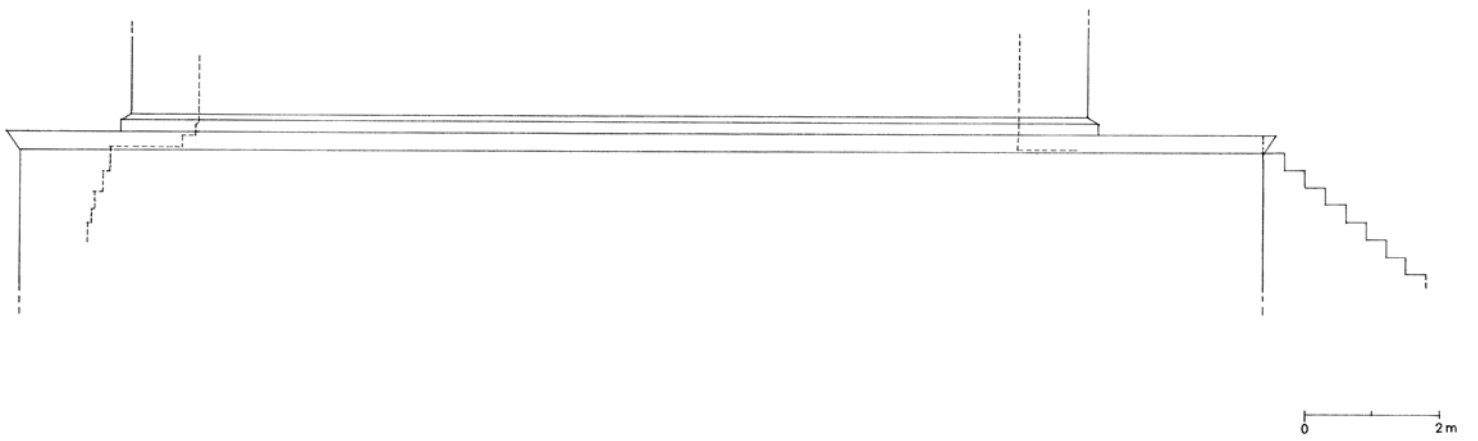

Fig. 119. Arapkhanchina (Shararai). Stupa V. Elevation, hypothetical reconstruction of the 1st and 2nd storey. (Martore 2004).

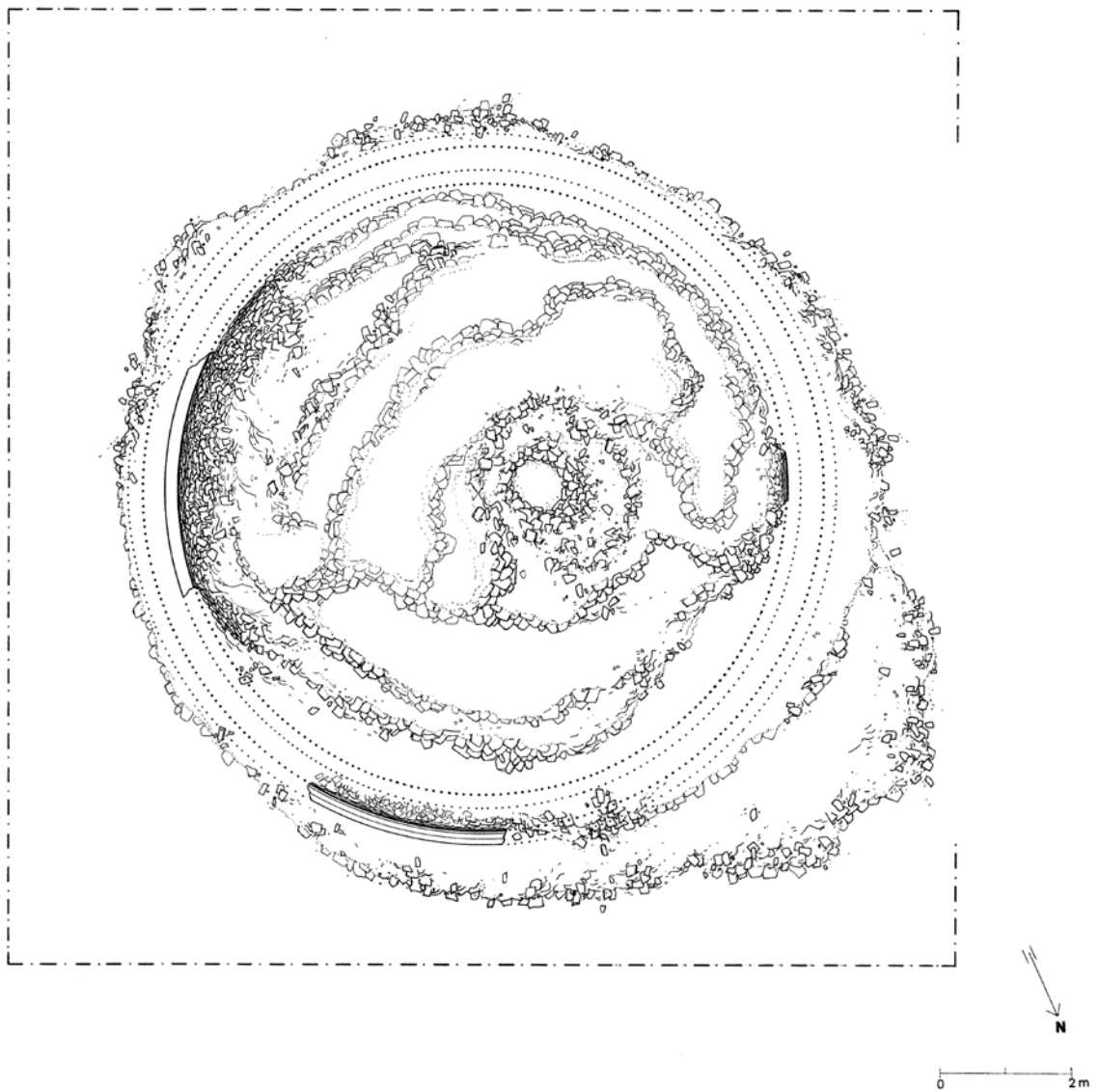

Fig. 120. Arapkhanchina (Shararai). Stupa VI. Plan. (Sabelli 1993; Martore 2004).



Fig. 121. Arapkanchina (Shararai). Stupa VI. N-S cross section. (Sabelli 1993; Martore 2004).

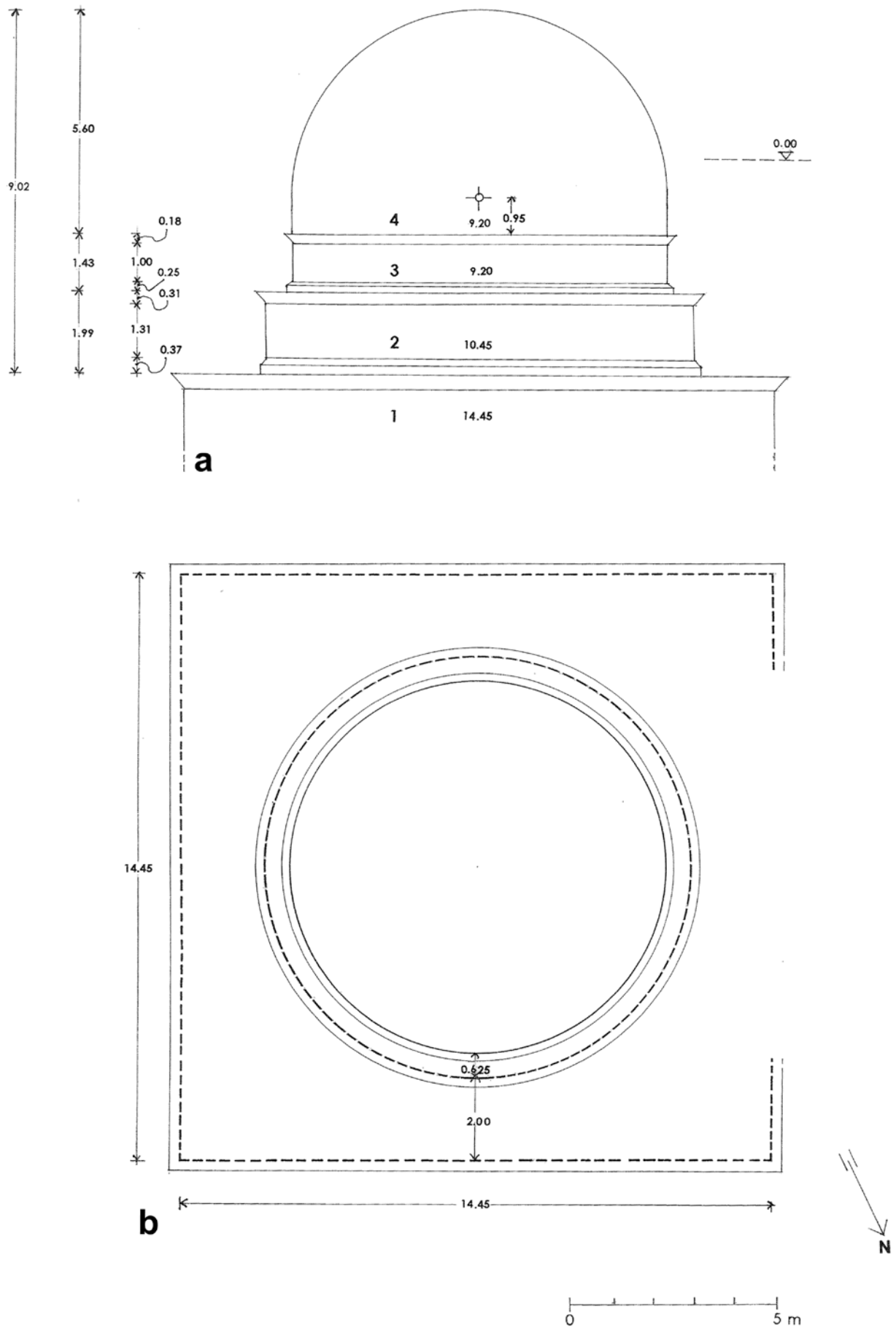

Fig. 122. Arapkanchina (Shararai). Stupa VI. *a.* elevation showing the measures. *b.* plan showing the measures. (Martore 2004).

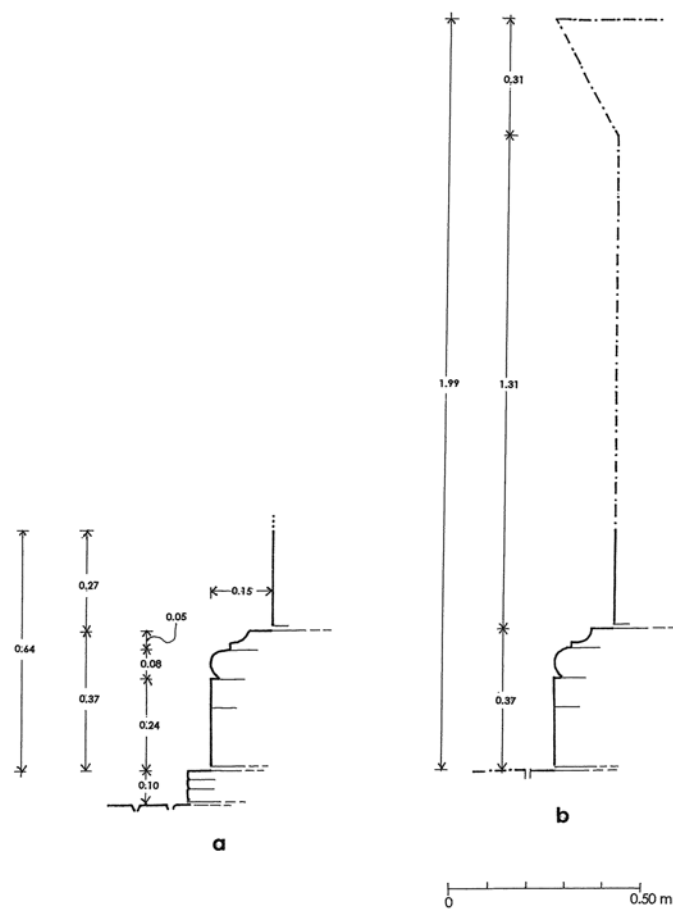

Fig. 123. Arapkhanchina (Shararai). Stupa VI. 2nd storey. *a.* profile. *b.* reconstructed profile. (Sabelli 1993; Martore 2004).

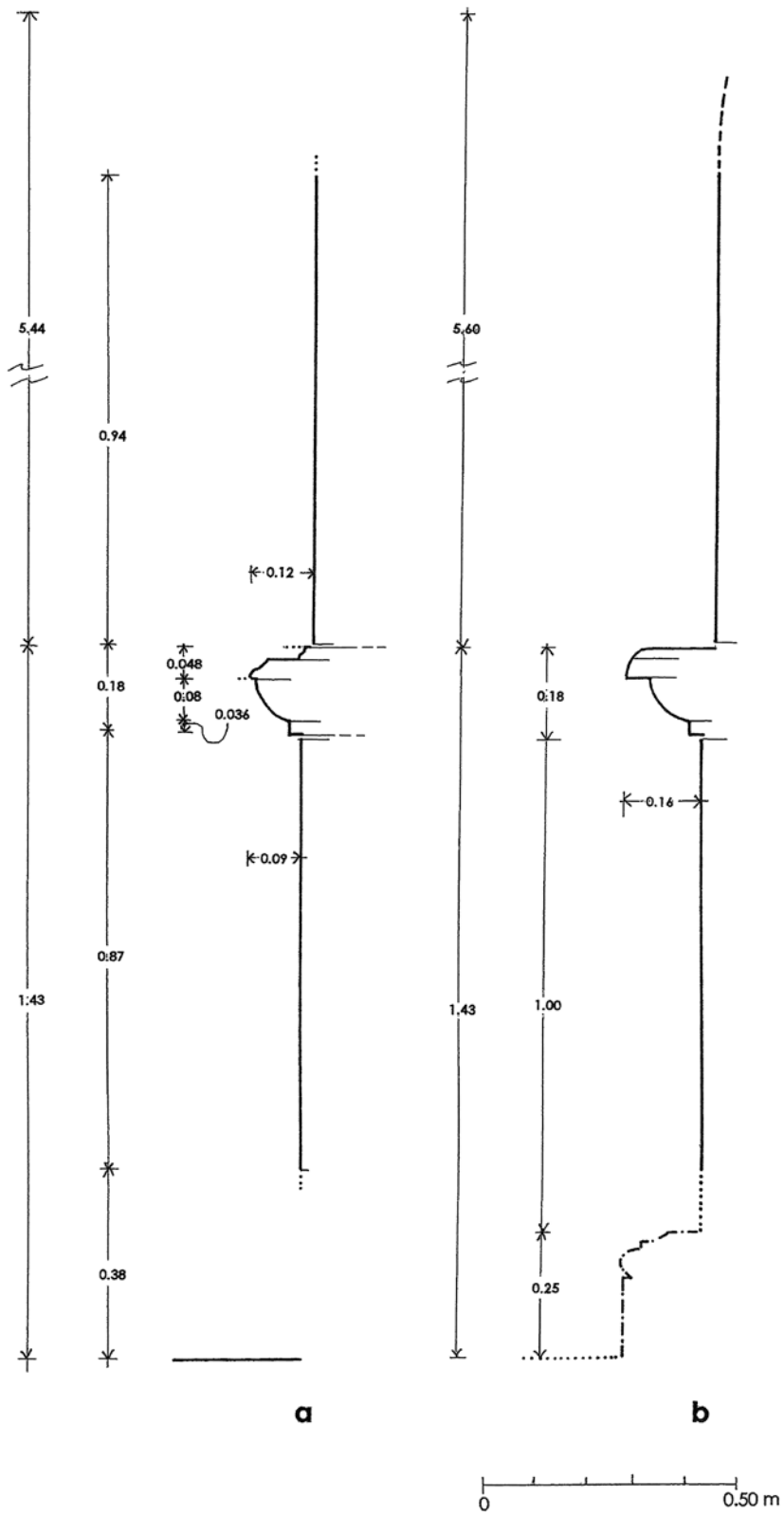

Fig. 124.
Arapkhanchina
(Shararai). Stupa
VI. 3rd e 4th
storey. a. profile.
b. reconstructed
profile. (Sabelli
1993; Martore
2004).

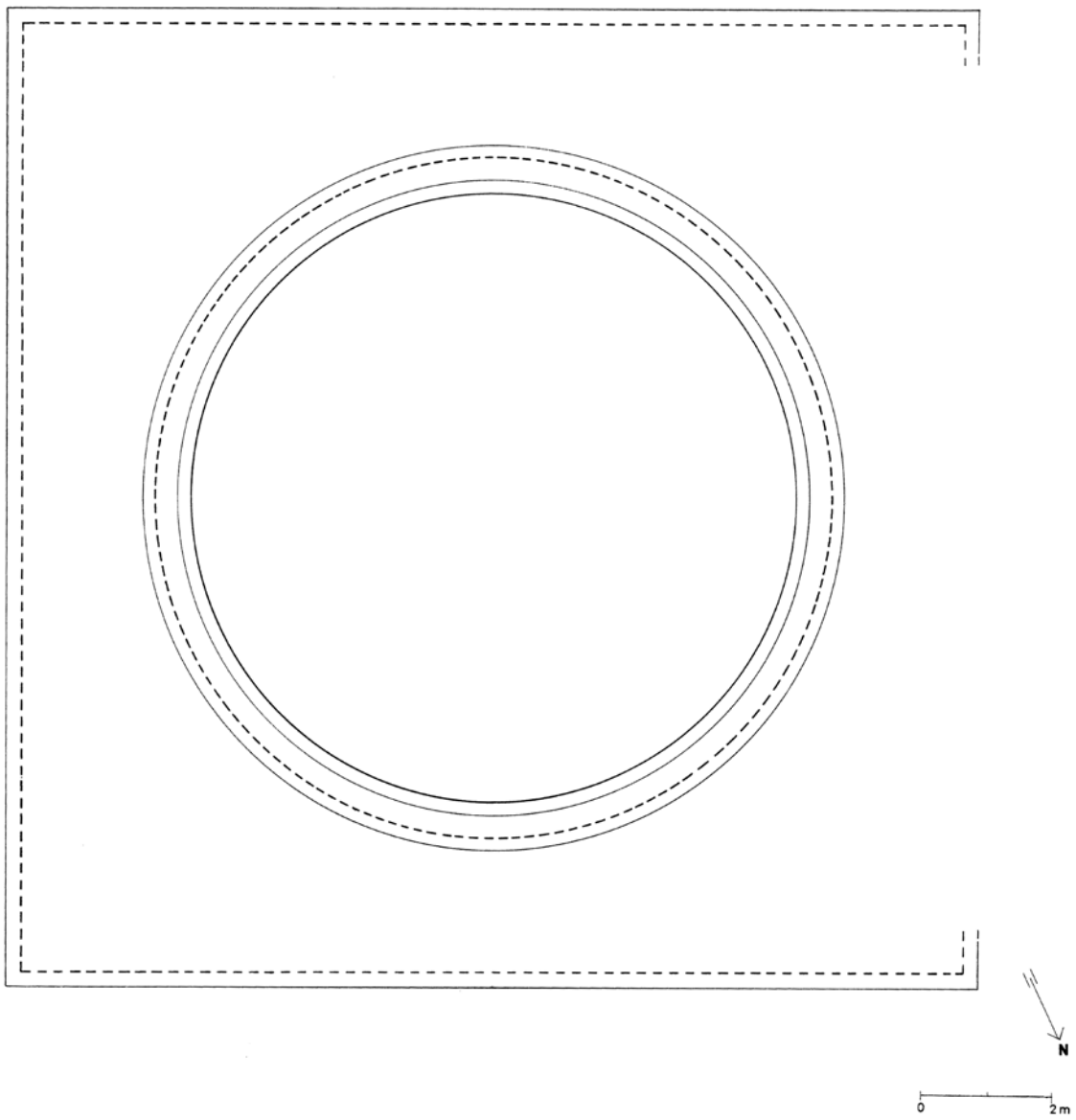

Fig. 125. Arapkanchina (Shararai). Stupa VI. Reconstructed plan. (Sabelli 1993; Martore 2004).

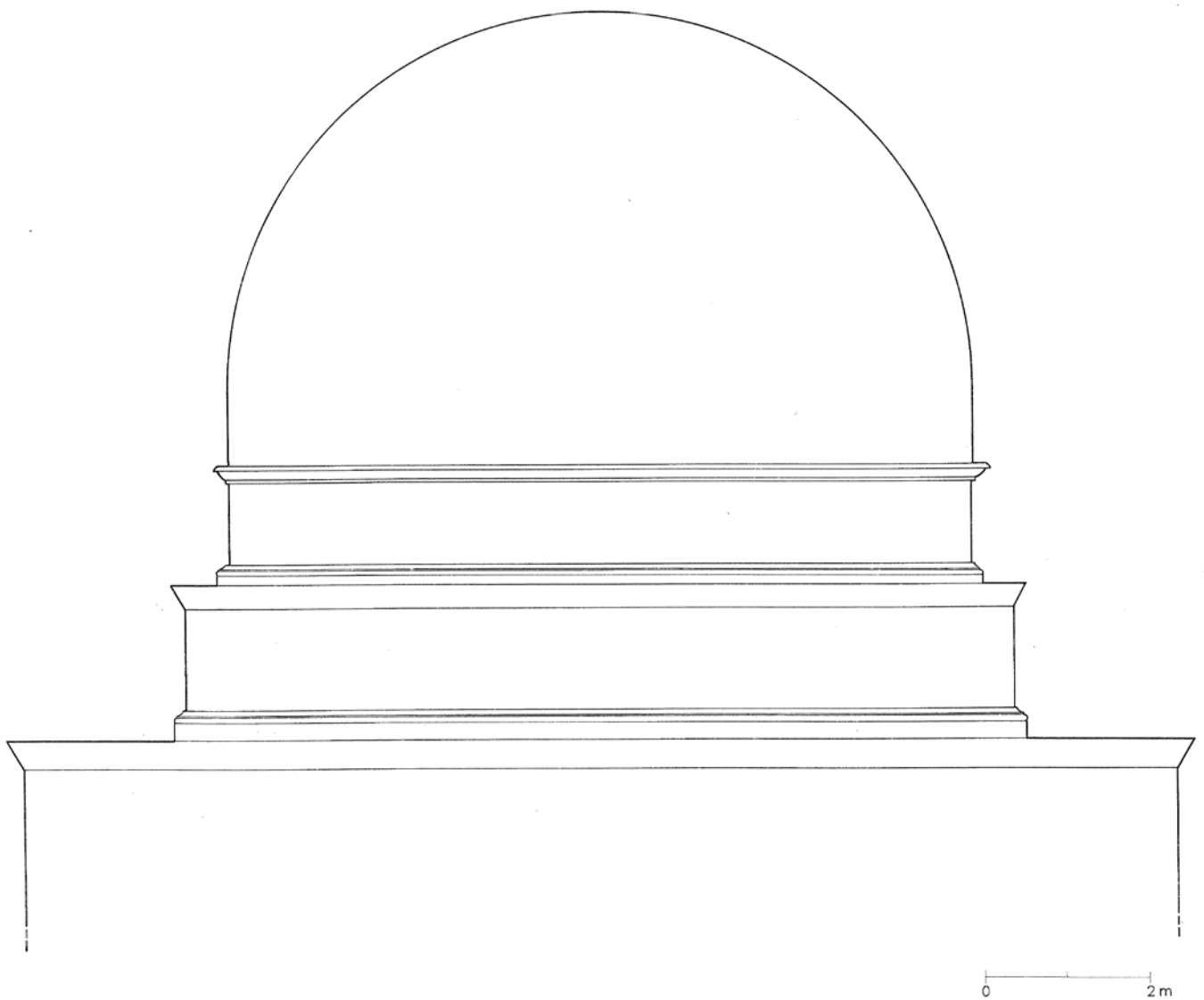

Fig. 126. Arapkhanchina (Shararai). Stupa VI. Reconstructed elevation. (Sabelli 1993; Martore 2004).

A5. The Great Stupa (GSt.) of Butkara I
(Fig. 127)

The Site

Zone of Jambil-Saidu. Jambil Valley.

Position: Lat. 34° 45' N; Long. 72° 22' E; SPM 43 B/5.

See the Introduction and the Conclusions.

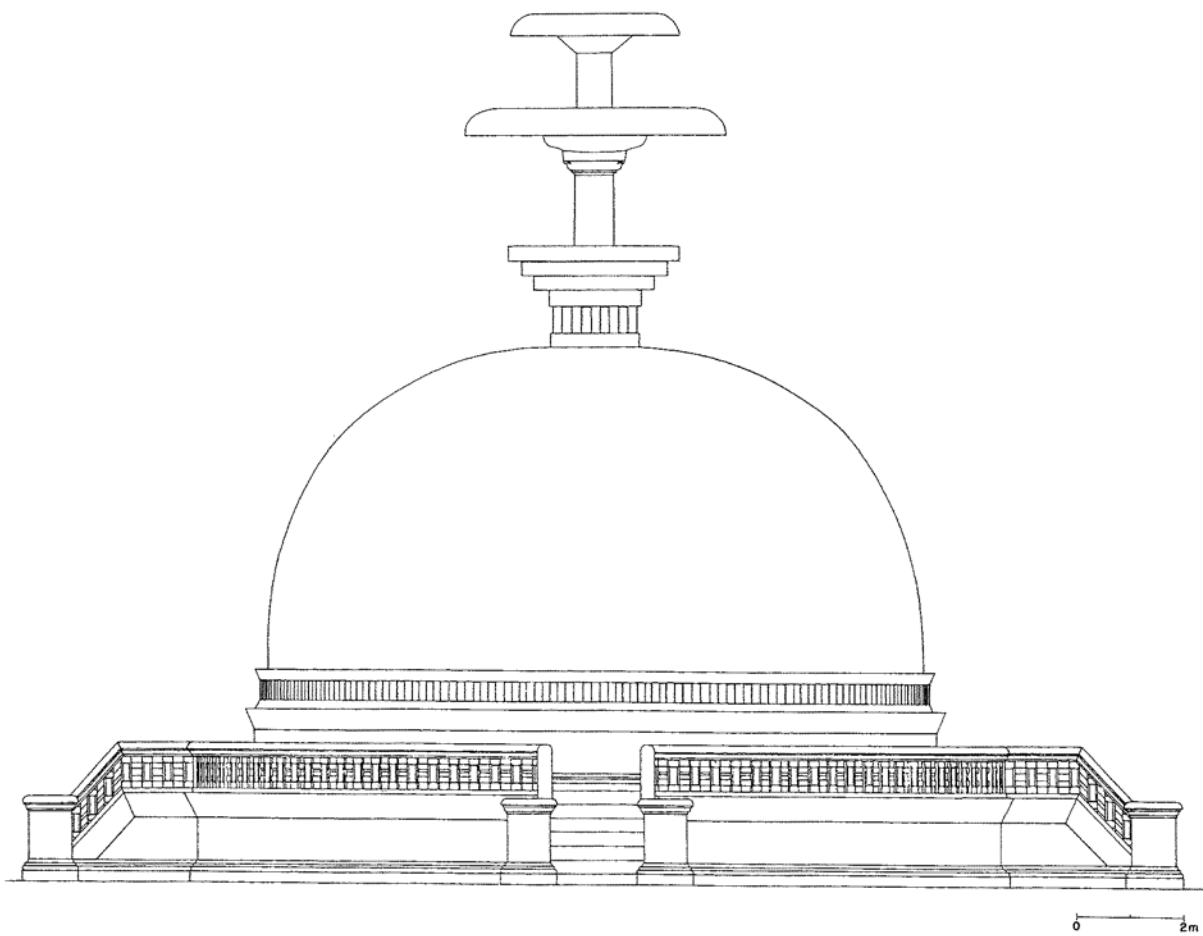

Fig. 127. Butkara I. GSt. 3, F4. Reconstructed drawing. (After Faccenna 2001: fig. 47a).

A6. Stupa of Saidu Sharif I
(Fig. 128)

The Site

Zone of Jambil-Saidu. Saidu Valley.

Position: Lat. 34° 35' N; Long. 72° 21' E; SPM 43 B/6.

See the Introduction and the Conclusions.

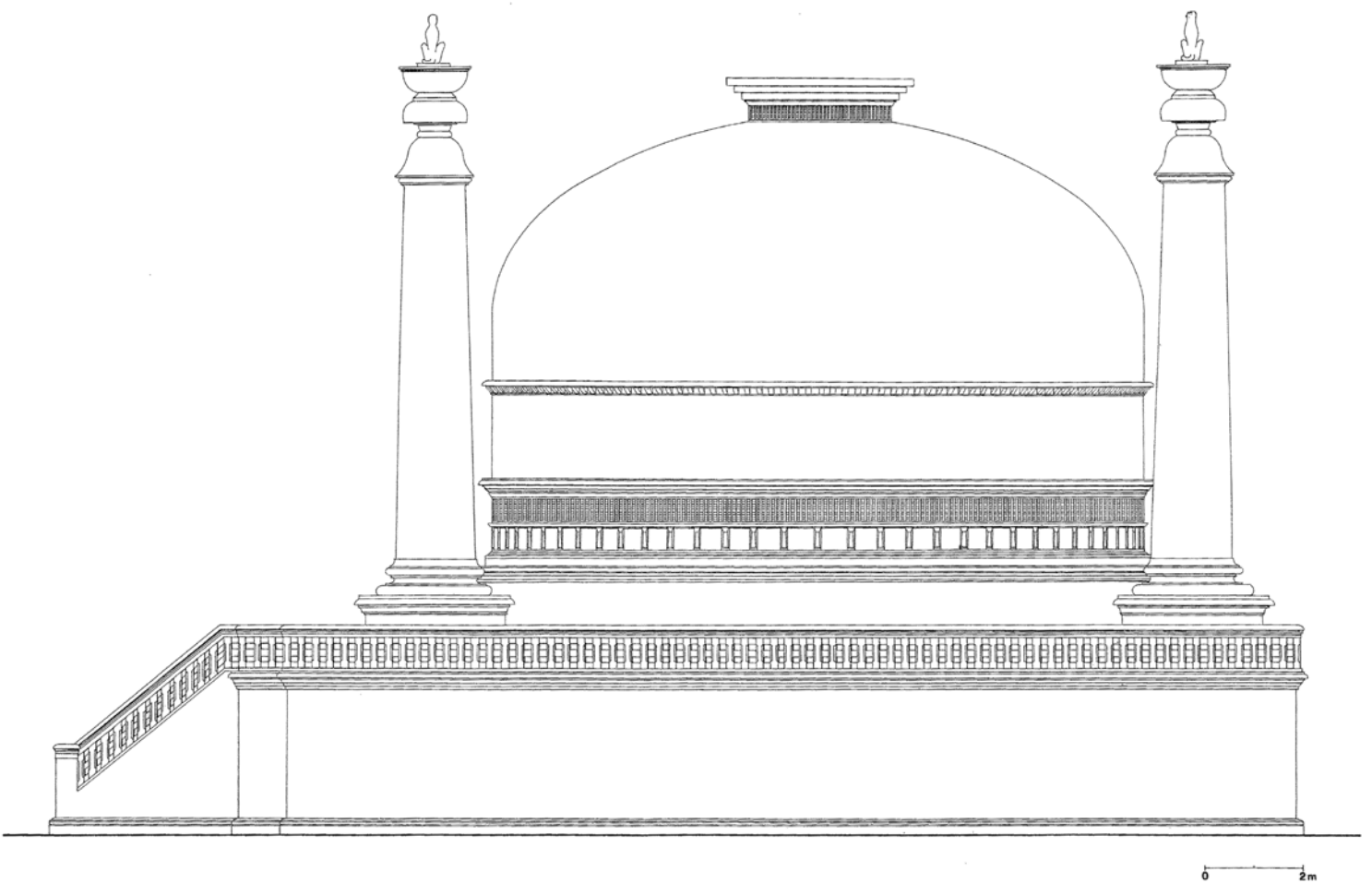

Fig. 128. Saidu Sharif I. Stupa. Reconstructed elevation of the side.
(After Faccenna 1995a: fig. 281).

A7. Stupa of Shnaisha

(Figs. 129-130)

The Site

Zone of Jambil-Saidu. Saidu Valley.

Position: Lat. 34° 43' N; Long. 72° 20' E; SPM 43 B/6.

See the Introduction and the Conclusions.

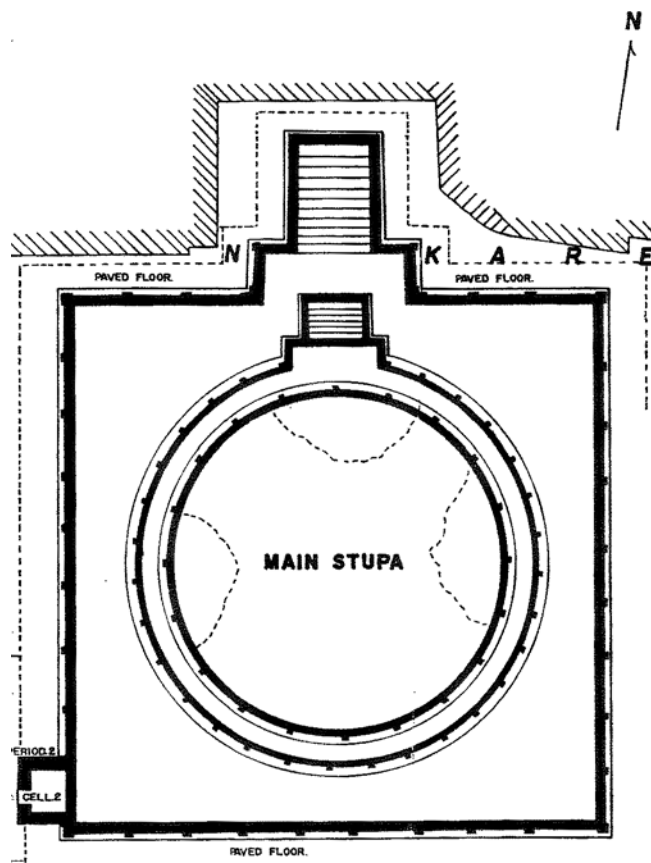

Fig. 129. Shnaisha. Stupa. Plan. (After Rahman 1993b: fig. 5).

A. Stupas

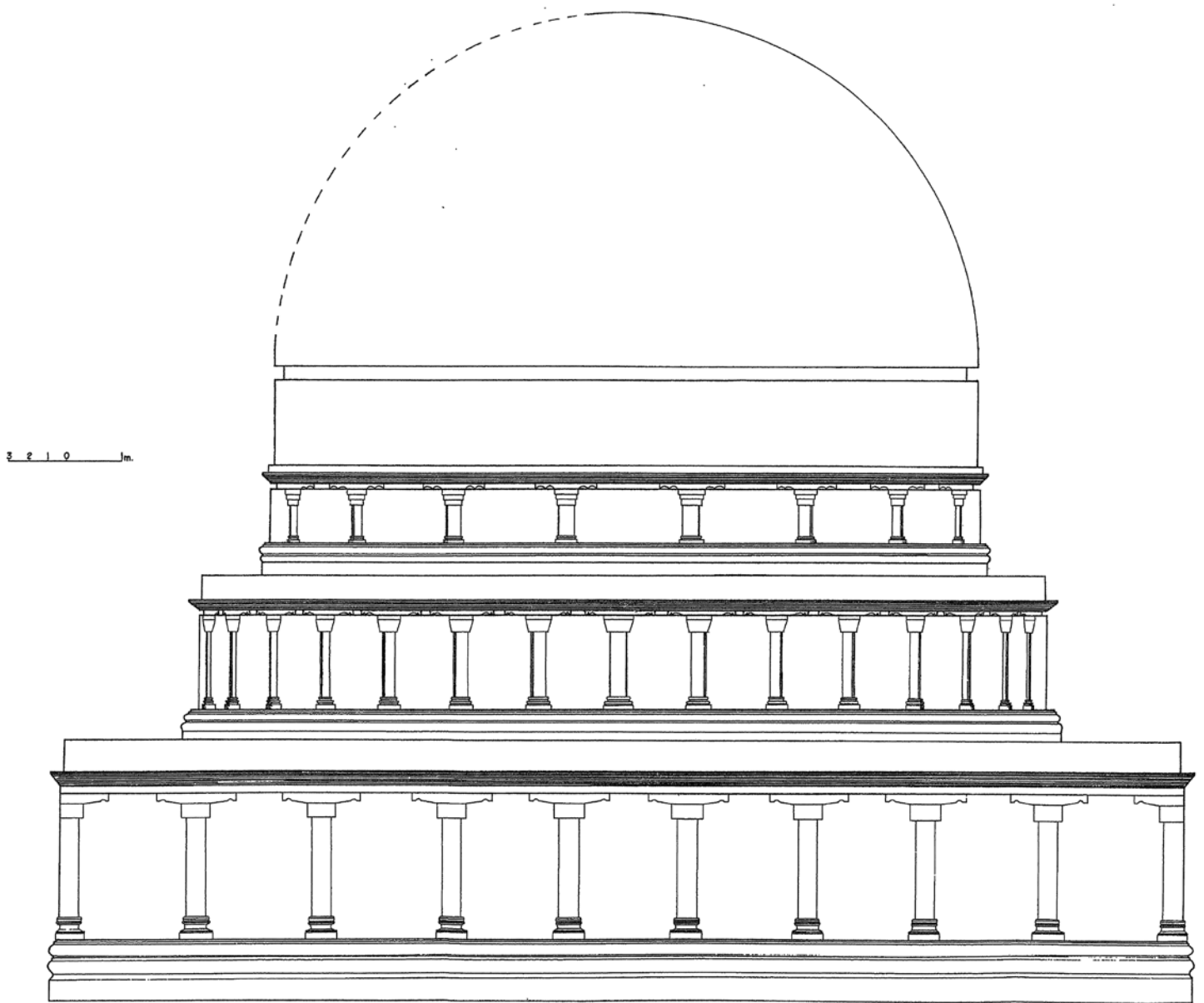

Fig. 130. Shnaisha. Stupa. Elevation, S side. (After Rahman 1993b: fig. 4).

A8. Stupa of Shankardar

(Figs. 131-159)

The Site

Zone of Barikot.

Position: Lat. 34° 41' N; Long. 72° 14' E; SPM 43 B/2.

From the main Mingora-Barikot road, immediately after the stone quarry of Ghalegai, on the left, a path skirts the rocky cliff and leads off towards the stupa. Now, on the rocky promontory, a new stone quarry has been set up and the stupa area can be accessed by a wide road further on, part of which has been asphalted. The area is surrounded by houses and the stupa is somewhat precariously protected by a wire fence.

The old road passed by the stupa to the W, as can be seen from the sketches made by Murray and Hobday during the 1897-1898 Malakand campaign.

The Badshah of Swat later established a new itinerary which was subsequently modified to form the present one (Stein 1930: 32).

The monument is one of the best known, if not the best known, in Swat owing to its position on the main road, its size and the fair state of conservation of its dome.

Bibliography and Documentation

The stupa was mentioned by H.G. Raverty 1863: 238-39, with a description and sketch by Raverty himself (1862) based on another by E.M. Smith, Surveyor General's Office, Calcutta Sept., 1862; the description is based on a report made by one of his representatives dispatched to Swat in 1858. In the sketch the stupa is depicted as having a cylindrical shape ending in a 'tower' and is decorated with superimposed rows of arches ⁽¹⁾.

⁽¹⁾ 'Proceeding on our route from Kottah, we saw the village of Nowaly-Kalaey, Abú-wah, Gurateay, Baríkott, Shankar-darah. Close to this latter place there is a tower called Shankar-dár. Shankar, in the Sanskrit

With a few variations the passage is quoted by Raverty 1878: 199 ⁽²⁾.

H.A. Deane (1886: 660), after being informed by local people, mentioned the stupa and the rock shaped like an elephant's head ⁽³⁾; later, with reference to the 1897-1898 Frontier Campaign carried out by the Malakand and Buner Field Forces, he was able to reconnoiter these places, arriving as far as Mingora.

During the same wartime period several tales are told about the Stupa of Shankardar: Murray Viscount Fincastel and P.C. Elliott-Lockart 1898: 109 with illustration, the work of Lieutenant Dixon, 16th Lancers (probable attribution for comparison with pl. on pp. 142-43) ⁽⁴⁾; E.A.P. Hobday 1898: 60, with illustration on

language, is one of the names of Siva. It stands on a square base of stone and earth, seven yards in height, and just forty yards in length and breadth, which I myself measured. On this square platform, the tower, which is of stone, joined by the dark coloured cement I before mentioned, stands. I computed the height, from the base, which I had measured, to be about thirty yards, or ninety feet; and I also measured the base, which was twenty-five yards or seventy-five feet in circumference. It is egg-shaped, as in the annexed sketch; and there is no road by which the summit may be gained, nor did it appear to be hollow inside; but there are small holes just large enough, to all appearance, to admit the hand, every here and there, which seem to have been indented to give light or air. From top to bottom the tower is vaulted like that of the mihráb of a mosque, but not so deeply indented or niched that one might place the foot thereon, but about a finger's breadth; and between each of these there is the hole, before mentioned. As the height increases, the táks or niches diminish in proportion. The Afgháns of the neighbouring villages have been removing stones for building purposes from the northern side of the tower, and have built several houses therefrom, hence it has sustained considerable injury on that side. The people tell all sorts of tales about the tower; and all agree that Akhúnd Darwezah, the celebrated saint of the Afgháns, who flourished from the year A.D. 1550 to 1600, gave out, in his lifetime, that this tower contained seven idols, one large, and six smaller ones'.

⁽²⁾ 'Setting out from the village of Koṭa'h, and passing near the villages of Nowaey Kalaey, Abú-wah, Gurateay, and Barí-koṭ, you come to Shankar-dár. Close to this latter place there is a T̄op, a cupola or tower, called the Burj-i-Shankar-dár, or Tower of Shankar-dár. The word Shankar, in Sanskrit, is one of the names of Shíw or Shiwá. It stands on a square platform of stone and earth, seven yards in height, and just forty yards in length and breadth, which my informant measured. On this square platform, the cupola or tower, which is of stone, joined by the dark-coloured cement before mentioned, stands. My informant computed the height, from the platform, which he had measured, to be about thirty yards, or ninety feet; and he also measured the base of the T̄op, which was twenty-five yards or seventy feet in circumference, and egg-shaped at the top. There is no way by which the summit may be reached, nor did it appear to be hollow within; but there are a number of small holes just large enough, to all appearance, to admit the hand, and which seem to have been indented to give light or air. From top to bottom the tower is vaulted without like the mihráb of a mosque, but not so deeply indented or niched that a person might place his foot thereon, but about a finger's breadth only, still the vaulted shape can be distinctly traced to the summit. Each niche or recess is about a yard or more in length and breadth, and between each of these there are the holes before mentioned. As the height increases, the táks or niches diminish in proportion. The Afgháns of the neighbouring villages have been removing stones for building purposes from the northern face of the tower, and have built several houses with the materials, hence it has sustained considerable injury in that direction. The people tell all sorts of tales about this tower; and all agree that A'khúnd Darwezah gave out, in his lifetime, that it contained seven idols, one large, and six smaller ones'.

⁽³⁾ 'A little further down the river, between Ghaligai and Shankardar, the natives of the country describe the remains of a stūpa as still standing; and this is undoubtedly that referred to by the Pilgrim — for the Pilgrim records next (p. 127) a large rock on the bank of the great river, shaped like an elephant. This rock is a conspicuous landmark existing near the river, about twelve miles from the village of Thana, and near Ghaligai. It is well known to the inhabitants of the valley, the name of which, Hathidarra, was derived from it. The stūpa is described by natives as still standing a few hundred yards distant from this rock; and, from what I can understand from the people, there is also a fine Deva temple near it'.

⁽⁴⁾ 'Among the numerous relics of Buddhism, which were the chief characteristics of the Swat Valley, one of which interested us greatly was a large 'stupa' or 'tope' near the village of Shankarghar in Upper Swat. This stupa was a conical mass of masonry with a flat circular surface above and a small chamber in its base, which

p. 61 ⁽⁵⁾. The two illustrations depict the stupa quite faithfully, above all Hobday's, viewed from the W with the mountains in the background and the path passing in front of the ruins. The lower structure of the stupa and the outer decoration appear to be well conserved.

In 1897 Stein (1930: 30) was able to observe it from a distance through his field glasses, from a position above Landakai.

It is cursorily described by Foucher (1905-1951: 74), taking it from a photograph (ibid.: fig. 16) received from Deane ⁽⁶⁾. An interesting comparison can be made between this photo and the almost contemporary sketches, in particular Hobday's, in which the picture is enlivened with the caravan (or troops) passing by the stupa along a path partially enclosed by several low boundary walls.

Thereafter, Stein 1930: 30-32, fig. 17, pl. 4 lower right, who illustrates it in detail ⁽⁷⁾; reported in Stein (1929: 49, fig. 21, with the caption: 'In foreground sunk

was almost completely enveloped in a heap of rubbish and stones. In these rubbish heaps, coins and fragments of idols are usually found in large quantities'.

⁽⁵⁾ 'On the 24th August we marched back from Mingaora to Burikot. Between Ghalegai and Burikot, near a small village called Shankardar, is a very fine old Buddhist 'Stupa', in excellent preservation. It has evidently been dug into frequently to search for treasure, but one side is nearly intact, and the stone-work fairly well preserved. There are other similar stupas in many parts of the valley, notably near Burikot, towards the Karikar Pass, but the one in the sketch was the finest we saw, and certainly the most complete'.

⁽⁶⁾ 'S'il a perdu son soubassement carré, dont les pierres ont servi à bâtir les murs modernes du voisinage, il a gardé la ceinture d'arcades qui, pour l'agrément des yeux, partage comme en deux tambours superposés sa partie cylindrique'. Caption to fig. 16: 'Ruines du *stûpa* de Barikot (Swât): ancient *Uttarasena-stûpa*. D'après une photogr. communiquée par le colonel Deane'.

⁽⁷⁾ 'On the morning of March 19th having dispatched my camp from Bîr-koṭ to the large village of Uḍegrām up the valley I proceeded to visit the great Stûpa of Shankardâr (fig. 17). It is situated two miles to the north-east of Bîr-koṭ village by the left side of the road leading to Saidu where it skirts the mouth of a small glen descending from a bare spur above the valley plain. I had already heard of this huge pile in 1897 and had even been able then to catch a distant glimpse of it through my glasses from the top of the Landakai ridge. I found it, alas, in a sad state of ruin. Owing to its situation by the main road of the valley and close to a series of villages lining the fertile alluvial lands by the river it had suffered terrible damage; for the whole village of Shankardâr, just below the ruin, and probably others also up and down the road had utilized the abundant stone material offered by this convenient quarry.

'Structural features of ruined Stûpa — All round the bases, the first of which was certainly square and very large, not only the well-carved facing stones but also the greater portion of the interior masonry had been removed, as seen in fig. 17. Through what remained of the lowest base the Bâdshâh's new road had been cut to avoid a detour through the village. The havoc thus wrought made it impossible to determine the exact dimensions of the ground plan. On the other hand the destruction of the bases has added to the impression created by the height of the Stûpa. From the rough measurements taken and shown in the rough section, pl. 4, the diameter of the dome and drum appeared to be about 62 feet which is less than that observed at the Stûpa of Amlûk-dara, and the height of the drum, decorated with two cornices, fully 16 feet. The extant height of the dome measured over the curvature is about 40 feet. Adding to these measurements the 34 feet measured between the foot of the drum and the lowest course of masonry laid bare in the cutting made for the road, we arrive at a total height of 90 feet for the Stûpa in its present sadly damaged state.

'The surviving masonry facing shows as at Amlûk-dara large dressed slabs of white stone divided sideways by small columns of dark slaty pieces and narrow horizontal 'packing' between the courses. In places remains of originally white stucco covering the outside of the drum can be seen. A peculiar feature of the drum is the decoration of the lower portion to a height of 6 feet with pilasters, projecting but slightly and bearing rather flat brackets (see pl. 4). The cornice above them is about 2 feet high and comprises a plain course of slabs and above this a projecting 'chajja' carried by thin slabs set vertically on their shorter edge. The upper cornice is marked by a shallow recess, about 11 feet high, producing a light-and-shade effect. A large cutting made on

road cut through outer base of Stupa’); Barger & Wright 1941: 33 (with concise mention, ‘one of the best preserved’); Tucci 1958: 299-302 (identification and proposed location; see below).

The visit to Swat by H.G. Franz, who mentions it, may be dated to this year (1959: 141 ⁽⁸⁾; 1965: 88, fig. 146 ⁽⁹⁾), together with that of Amluk Dara (erroneously indicated as Top Dara); 1959: 141 (fig. 10; 1965: 88, fig. 142).

Restoration work carried out in 1972, 1973, 1979 and 1982 by the Department of Archaeology and Museums of Pakistan in the W and N sections involved part of the 3rd and 4th storeys and the dome, as well as the consolidation of the more corroded and eroded parts of the underlying storeys; the date of the execution of the restoration work is carved into the facing blocks. This work is summed up in Pl. 152.

Gui and Cimmino 1964: graphic documentation.

Sabelli 1993: graphic survey of the monument.

Martore 2003: graphic revision and updating.

Photographic documentation: performed on a number of occasions by the Italian Mission, starting with F. Bonardi Tucci and M. Taddei (1959), and latterly (2004) by P. Spagnesi. Subsequently by Pakistani and foreign missions, and by single individuals.

It is mentioned by:

Khan Ashraf 1993: 53-55, pl. XII (sketch by Naud Kamal with reconstructed plan and elevation), figs. 41-42 ⁽¹⁰⁾; Badshah Sardar and Saleem-ul-Haq 1997: fig.

the north-western side of the dome now renders the broken top of the Stūpa accessible. By digging down in the centre the masonry lining of a shaft about 5 feet square has here been laid bare. This excavation appears to have been carried down only to about 15 feet from the present top of the dome. Hence it is possible that the mass and solidity of the masonry have here defeated the efforts of treasure-seekers, and the central deposit may still be intact’.

⁽⁸⁾ ‘Dieser zylindrische Oberbau ist in dem Stupa des Königs Uttarasena in Shankardar trotz aller Zerstörungen noch am vollständigsten erhalten. Zwei zylindrische Ringe stehen übereinander, der untere durch Pilaster gegliedert, der obere leicht eingetieft. An letzterem deuten Spuren von Mörtel oder Stuckbewurf darauf hin, daß entweder Malereien angebracht waren oder Stuckdekorationen aufgebracht waren, vielleicht in Form ganz einfacher geometrischer Ornamente, wie sie an einem der kleinen Modellstūpas angedeutet sind, oder eine dekorative Pfostenbalustrade umlief, wie sie von kleinen Stūpas in Stein erhalten ist’.

⁽⁹⁾ ‘Sehr eindrucksvoll wirkt auch durch die landschaftliche Lage der sogenannte Stupa des Königs Uttarasena in Shankardar. Obwohl stark zerstört, ist er doch noch bis zum Oberbau erhalten. Zwei zylindrische Ringe stehen hier übereinander, der untere durch Pilaster gegliedert, der obere, leicht zurückspringend, mit Spuren von Mörtel- oder Stuckbewurf als Überresten einstiger Bemalung oder von Stuckdekorationen. Man wird sich diese in Form einfacher geometrischer Ornamente vorstellen, wie sie einer der Model-Stupas im Museum zu Peshawar zeigt. Vielleicht lief auch eine Pfostenbalustrade um, die ebenfalls von Klein-Stupas bekannt ist’.

⁽¹⁰⁾ ‘Originally the plinth of the stupa was square in plan, but the inhabitants of the village removed the well-dressed facing stone and also the great portion of the interior masonry around the podium, for construction of their houses and road .

‘The stupa consists of lower drum decorated with two cornices, upper drum and a dome measuring 12m. The total height of the stupa from dome to the existing base is 27m.

‘The masonry comprises large dressed slabs of white stone separated by small columns of dark slatey

8; Kurita 2003, I: 237 (fig., top); Khan Ashraf and Lone 2004: fig. on p. 31 ⁽¹¹⁾; Badshah Sardar 2005: fig. on p. 53; Filigenzi 2007: 234, fig. 5.

Identification

Like Deane (1896) previously, Stein (1930: 31-32) identifies the Stupa of Shankardar with that attributed to Uttarasena, king of Wuchang-na (Swat), according to a local tradition reported by Xuanzang (Julien 1857-1858, I: 139; Beal 1885, I: 126; Watters 1904-1905, I: 236). Near Ghalegai, by the road side, there is a rock (Stein 1930: fig. 24) resembling the profile of an elephant's head and trunk; a short distance away lies the large rock carving of a sitting Buddha, at the time covered by a pile of stones up to the damaged head, and the cave with the relief of Tindodag (Filigenzi 2000: figs. 5-8).

Deane's and Stein's identification did not convince Tucci (1958: 299-302) who pointed out that, despite the undeniable importance of the place, there were no traces of any monastery or the like; the elephant must have died after reaching the region of Uddiyana, i.e. the border, and there the stupa must have been erected; the elephant rock is more than 1 km further N; the distance (30 km) must be calculated from Mingora and not from Manglawar on the basis of its identification with Mengjieli, the capital; the associated stupa must be sited near Nawagai Kota where indeed a large stupa and ruins lie.

The Buddha carving was rendered fully visible by order of the Wali, at the suggestion of Tucci (*ibid.*: 294, fig. 6).

pieces, and narrow horizontal packing between the courses.

'Some traces of stucco plaster on the drum are still visible.

'The lower drum measuring 4.87m is garnished with slightly projected pilasters with one bearing rather flat brackets.

'The cornice above the lower drum is 0.60m high and comprises a plain course of slabs and above this a projected part built in thin slabs which are set vertically on their shorter edge.

'The upper cornice is marked by a shallow recess about 0.50m high producing a light and shade effect. The stupa dome was cut on the north-western side by antiquities robbers, a common practice in this area. On the eastern and southern sides of the stupa about 15 meters from the base, traces of Buddhist settlement can be seen, now occupied by the modern houses.

'The masonry of these latter structures is very rough and probably belongs to a monastery complex. Due to the importance of this imposing stupa, the excavation at the site as stated earlier, becomes operative for the protection and preservation of the monument'.

⁽¹¹⁾ 'It is very beautiful unexcavated Stupa in the Valley concealing great potentiality of relics. It belongs to 1st-3rd century AD'.

The Stupa

The stupa lies at the foot of the Shankardar mountains, where the ground slopes away towards the S and W in the direction of the fields, on the plain traversed by the Swat river.

1st Storey, Quadrangular in Plan, and 2nd Storey, Circular in Plan

Of these first two storeys there remains the badly deteriorated core, which presents one, larger, mass corresponding to the 1st storey, also largely buried, and another corresponding to the 2nd storey, which has been reduced up to the level of the profile of the storey above. The 1st storey on the W side, where the larger part of its core still remains, presents a row of blocks and thin slabs with unfinished surfaces, typical of the alignments connected with specific structural elements; it conceivably corresponds to the storey of the stupa connected to a stairway, thus suggesting the existence of the latter on the W side. The top of the 1st storey can obviously be located above the conserved core although it is not possible to determine the exact level; its height is indeterminable. It is likewise impossible to determine the height of the 2nd storey, the upper level of which may be inferred by guessing the height of the base of the 3rd storey, which is also missing. There was probably a stairway in the same axis as the one below. Therefore the measures given for the plan and elevation of the 1st and 2nd storeys are only hypothetical, like the set-back of the 2nd vis-à-vis the 1st storey and the stairway with the ramp of the 1st storey with its 28 steps and inclination of 38° and that of the 2nd with 17 steps and an inclination of 37°. Examination of the core composition revealed no significant differences regarding base and cornice mouldings, also because it was set well back from the front. There is some indication of the presence of large and more closely spaced blocks at the lower level of the 2nd storey.

The core is made of large slabs of different stone and marble, with plentiful smaller and clay items.

3rd Storey, Circular in Plan (Drum)

The base is missing, with perhaps only a few supporting projecting slabs at the base of the pilasters remaining; the wall decorated with pilasters has been conserved together with the corbelled cornice. The reconstructed h. of the storey is 2.56, and the diam. 23.00. The pilasters total 45 in number with an interaxis of 1.69; there are 213 brackets, 17 of which missing.

The pilaster has a scotia type base with stone plinth and with the other overlying members made of thin schist slabs, one for each of them.

The gently tapering shaft is made of small blocks and slabs laid side-wise, alternating with small blocks that occupy the entire width of the shaft, separated by a row of small slabs. The capital is made of bands obtained using small stone blocks, of which the second last one above has projecting rectangular teeth; on top of this is the abacus with its two extremities projecting on the side and in front, made of thin schist slabs; probably the bearing structure of a plaster (stucco?) coating comprising a Gandharan-Corinthian capital. It is closed by a modillion obtained from a single schist slab, ending at each extremity on the lower face with a recess and with a projecting fillet above it.

Resting on this is the architrave with two bands, the upper, projecting one, composed of small blocks and slabs, with a fillet separating the two bands. Then comes the corbelled cornice. Below this we have: fillet, ovolo, double fillet, each made out of a row of schist slabs; this is followed by the corbel with cyma reversa, obtained from a single schist block. On top, three projecting covering fillets made of schist, corroded, and the remains of an element, certainly a reverse ovolo. As usual there is no coping slab.

The wall has seven rows of stone blocks.

The building technique consists of limestone blocks with thin schist slabs filling in the gaps. The blocks are not particularly large.

Alternating in the spaces between the pilasters, corresponding to the third row from the top at about half their width, there are holes measuring 0.15 h. x 0.10, depth 0.60-0.80, whose regular level and distance mean that they were certainly putlog holes (observation by R. Sabelli; the time of their execution cannot be determined).

Traces of plaster remain in the cornice, in the bracket spacers, both at the back and on the sides, increasing the thickness of the individual brackets.

4th and 5th Storey (Composite Dome)

4th Storey, Circular in Plan, Transition Element.

Having a base of two-three rows of small, slightly projecting slabs, it (h. 2.53) begins flush with the 3rd storey; it then rises slightly, with twelve rows of blocks enclosed by small schist slabs. Numerous plaster traces are visible. The top part ends in a recess (h. 0.37, depth 0.30-0.37). In it, in the upper empty part, several rows of schist slabs have been conserved. It was closed by rows of schist slabs which thus blocked at the base a moderately projecting row of schist slabs which obviously had the function of draining the rain water (cf. Shnaisha, Barikot, no longer extant, and Abbasahebchina). It represents a typical solution for this type of monument.

5th Storey, Raised Dome

Resting on a projecting row of slabs and aligned with the base of the storey below, the dome first rises vertically, and then curves to form a semi-circle. The surface has been conserved up to a height of 7.34, while, including the core, it attains a h. of 10.32. Extensive traces of thick plaster remain. It must have attained a height of 11.70.

There is a large gap on the SW side. Stein describes the presence of a cavity in the centre which displayed a recess with a side length of 5 feet to take the pole supporting the upper structure and descending to a depth of 15 feet, perhaps leaving the relic deposit still intact. This important fact was not reported either in Gui and Cimmino's survey or in Sabelli and Martore's (1993, 2003).

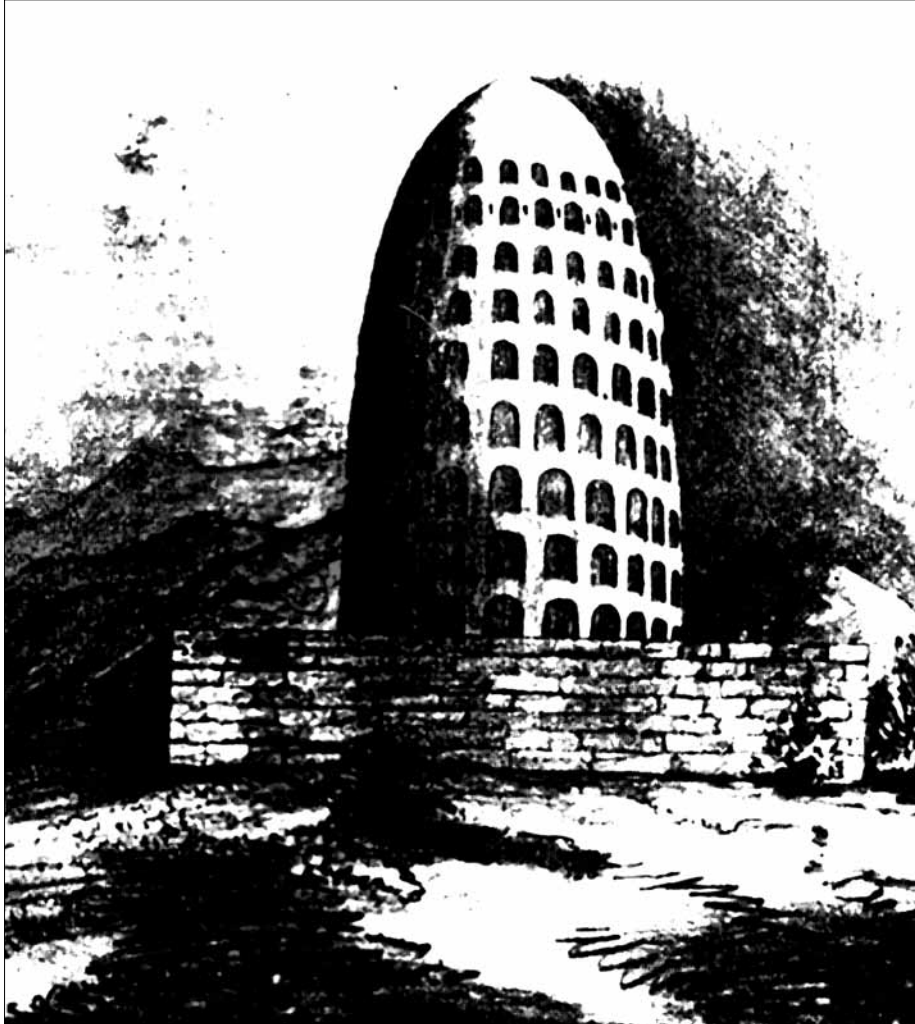

Fig. 131.
Stupa of
Shankardar.
Drawing of
the stupa.
(After
Raverty
1863: fig. on
p. 109).



Fig. 132.
Stupa of
Shankardar.
Drawing of
the stupa.
(After
Fincastel
& Elliott-
Lockart
1898: fig. on
p. 142).



Fig. 133. Stupa of Shankardar. Drawing of the stupa. (After Hobday 1898: fig. on p. 61).



Fig. 134. Stupa of Shankardar. N side. (After Foucher 1905-1951, I: fig. 16).

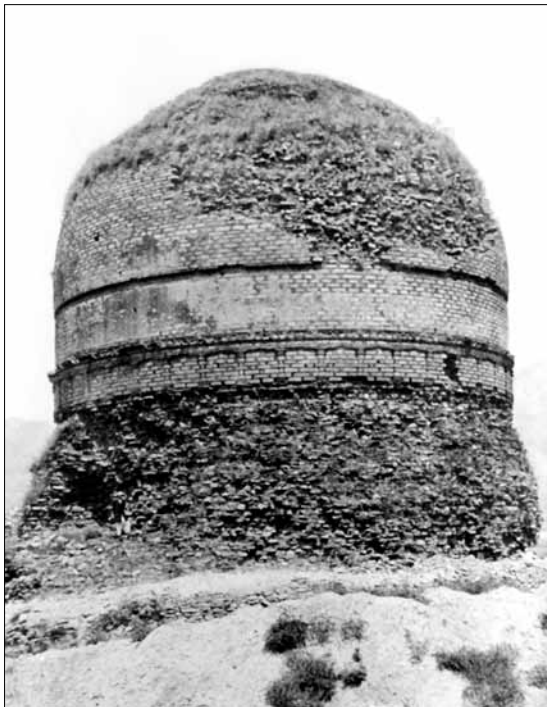

Fig. 135. Stupa of Shankardar. N side.
(After Stein 1929: fig. 21).

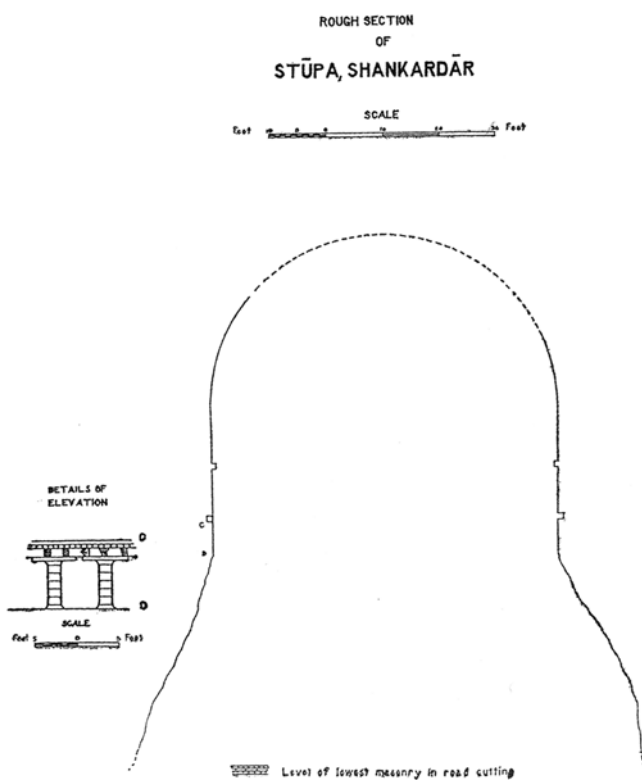

Fig. 136. Stupa of
Shankardar. (After
Stein 1930: fig. 17, pl. 4
on bottom right).



Fig. 137.
Stupa of
Shankardar.
(Taddei
1959; Neg.
CS).



Fig. 138. Stupa of Shankardar.
(Taddei 1959; Neg. CS).

A. Stupas



Fig. 139. Stupa of Shankardar. (Taddei 1959; Neg. CS).

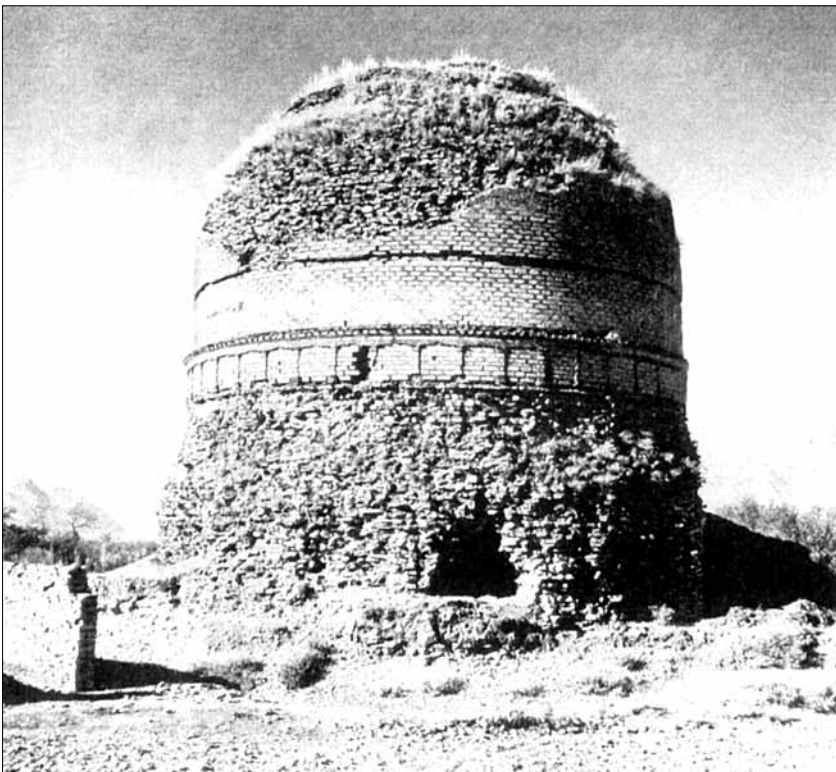

Fig. 140. Stupa of Shankardar. W side. (After Franz 1965: fig. 143).



Fig. 141.
Stupa of
Shankardar.
NW side.
(After
Higuchi 1984:
fig. on p. 148).

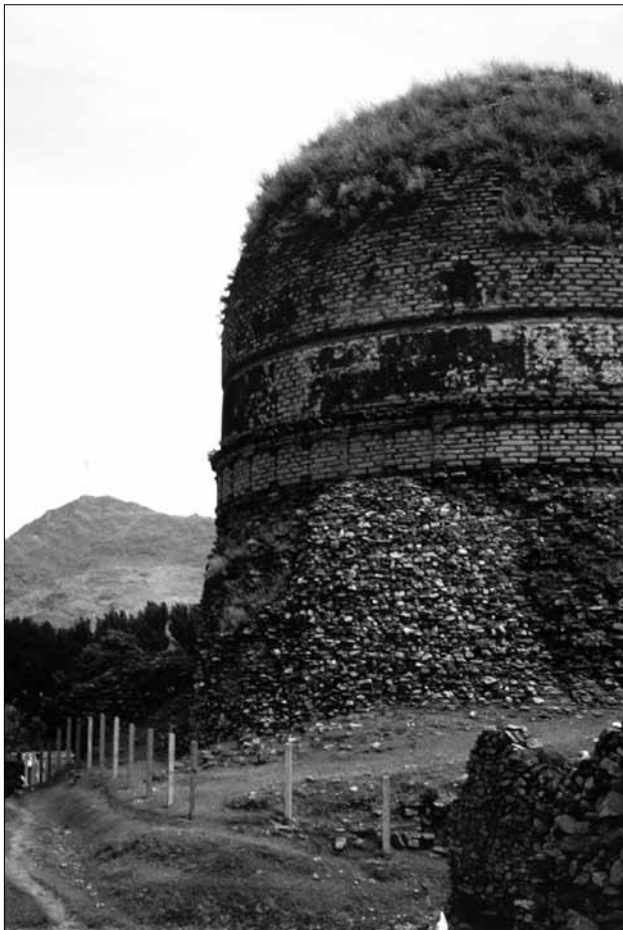

Fig. 142. Stupa of Shankardar. W
side, general view. (Sabelli 1993).

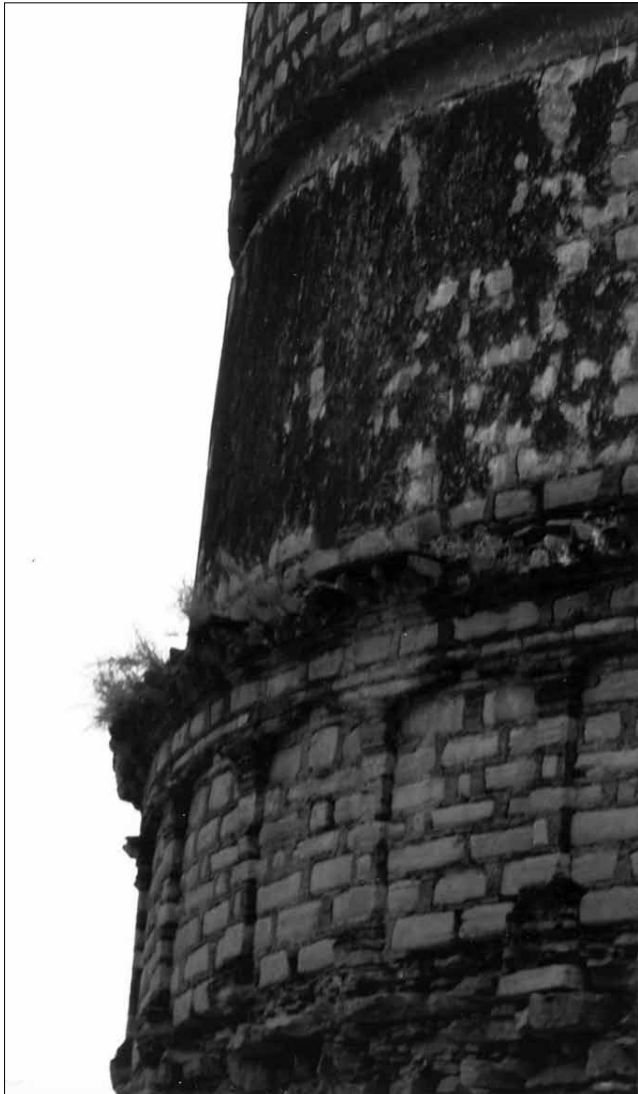

Fig. 143. Stupa of Shankardar. NW side; 3rd storey (drum), 4th and 5th storey: composite dome with transition storey, recess for projecting small slabs, and dome springer. (Sabelli 1993).



Fig. 144. Stupa of Shankardar. W side; 3rd storey (drum) with pilasters, cornice with architrave and brackets. (Sabelli 1993).



Fig. 145. Stupa of Shankardar. NW side; 3rd storey (drum) with pilasters, cornice with architrave and brackets; above 4th and 5th storey: composite dome with transition storey, socket and raised dome.



Fig. 146. Stupa of Shankardar. W side; 3rd storey (drum) with pilasters, cornice with architrave and brackets; above the 4th transition storey of the raised dome. (Sabelli 1993).



Fig. 147. Stupa of Shankardar. N side, general view. (Sabelli 1993).

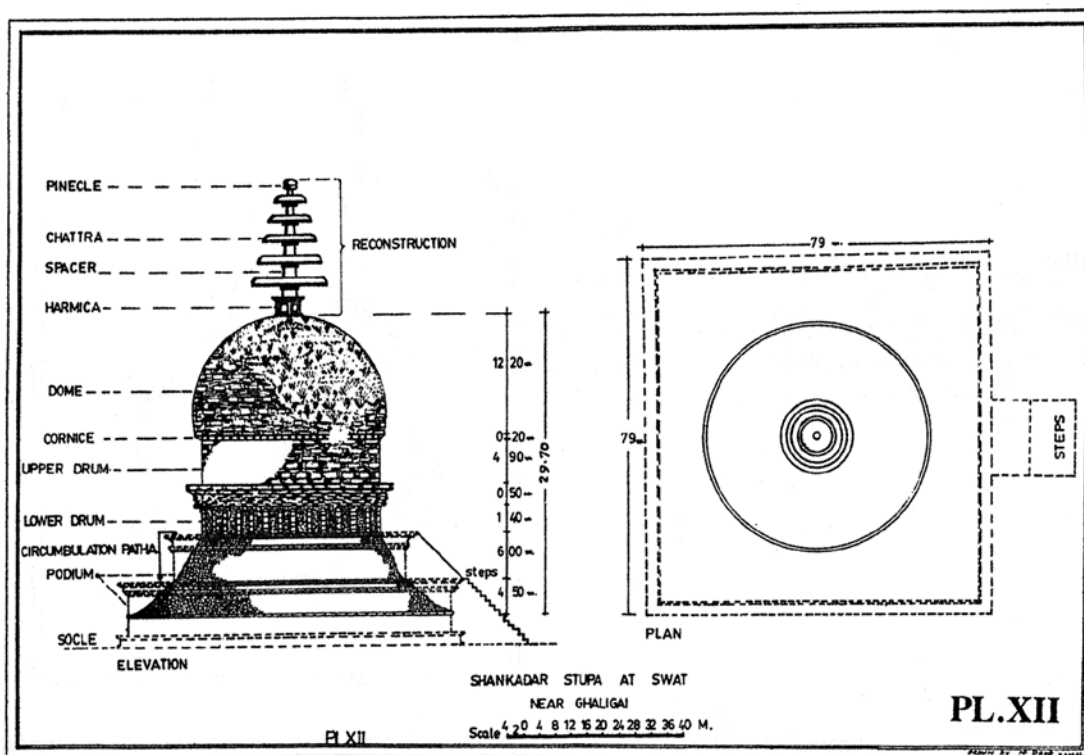

Fig. 148. Stupa of Shankardar. Plan and reconstructed elevation. (After Ashraf 1993: p. 25, pl. XII).



Fig. 149. Stupa of Shankardar. SW side, general view. (Spagnesi 2004).



Fig. 150. Stupa of Shankardar. NW side, general view. (Spagnesi 2004).



Fig. 151. Stupa of Shankardar. Plan. (Sabelli 1993; Martore 2003).

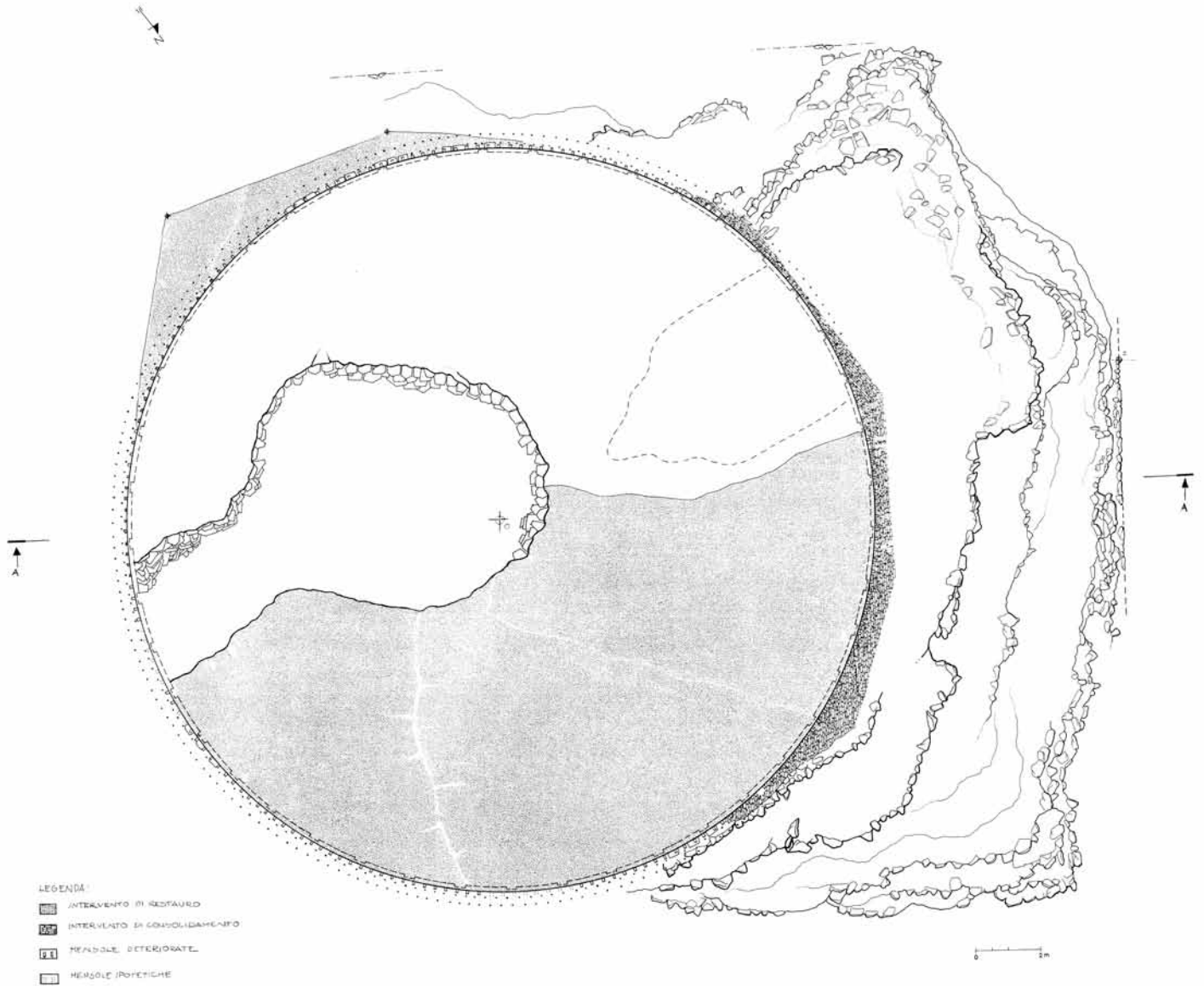

Fig. 152. Stupa of Shankardar. Plan showing the restoration and consolidation work. (Sabelli 1993; Martore 2003).

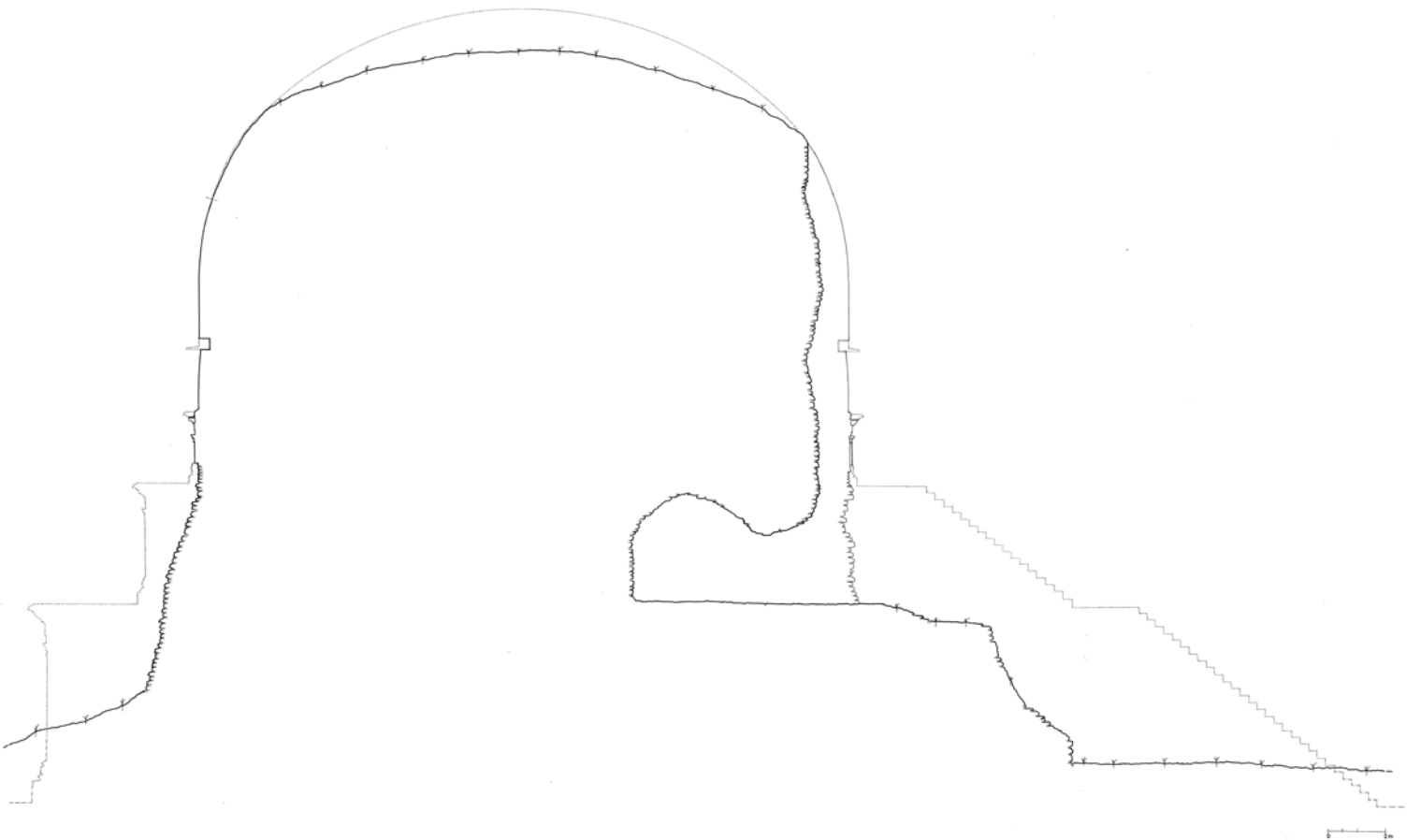

Fig. 153. Stupa of Shankardar. Cross section. (Sabelli 1993; Martore 2003).

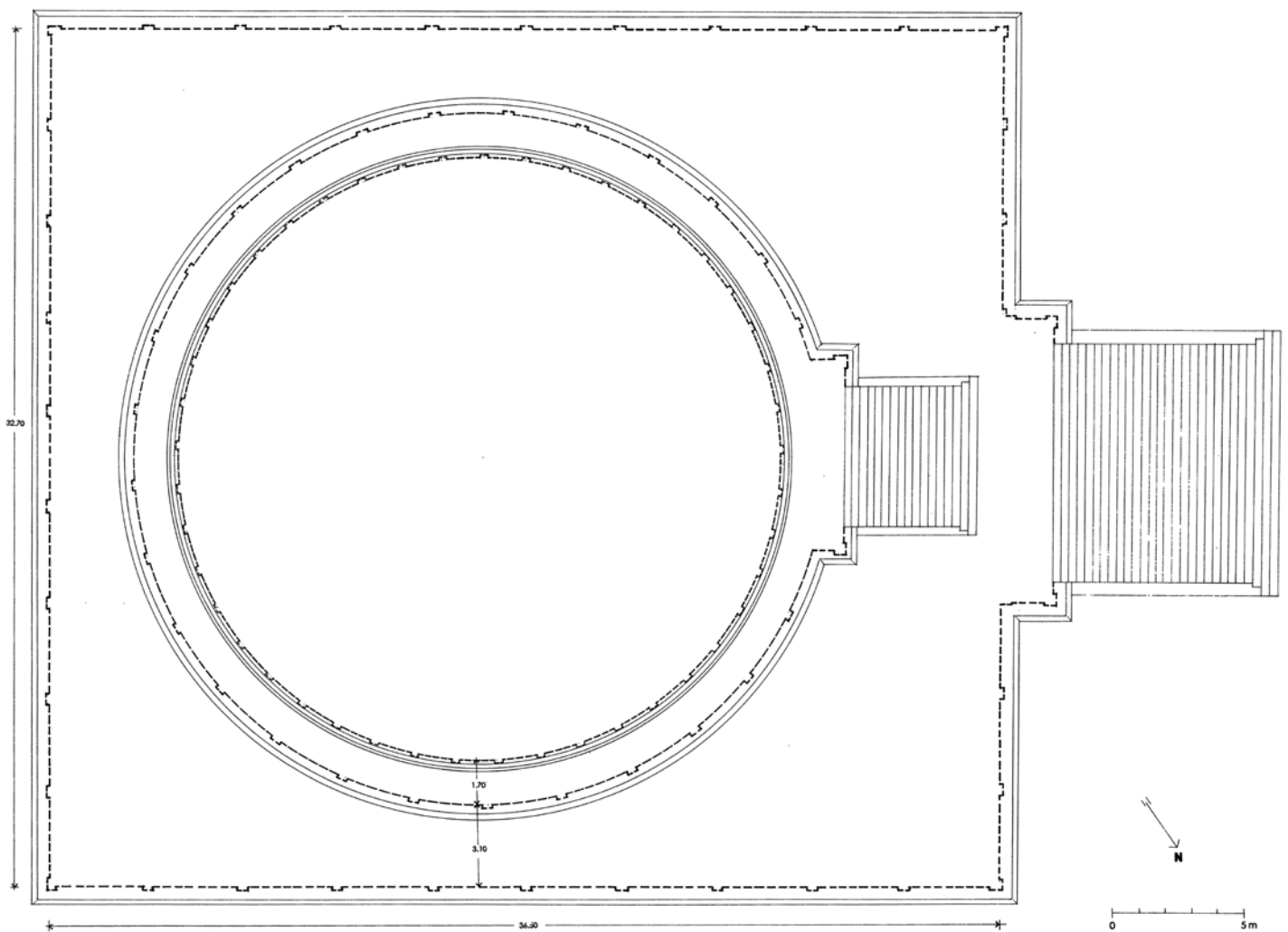

Fig. 154. Stupa of Shankardar. Sketch plan showing the measures. (Sabelli 1993; Martore 2003).

A. Stupas

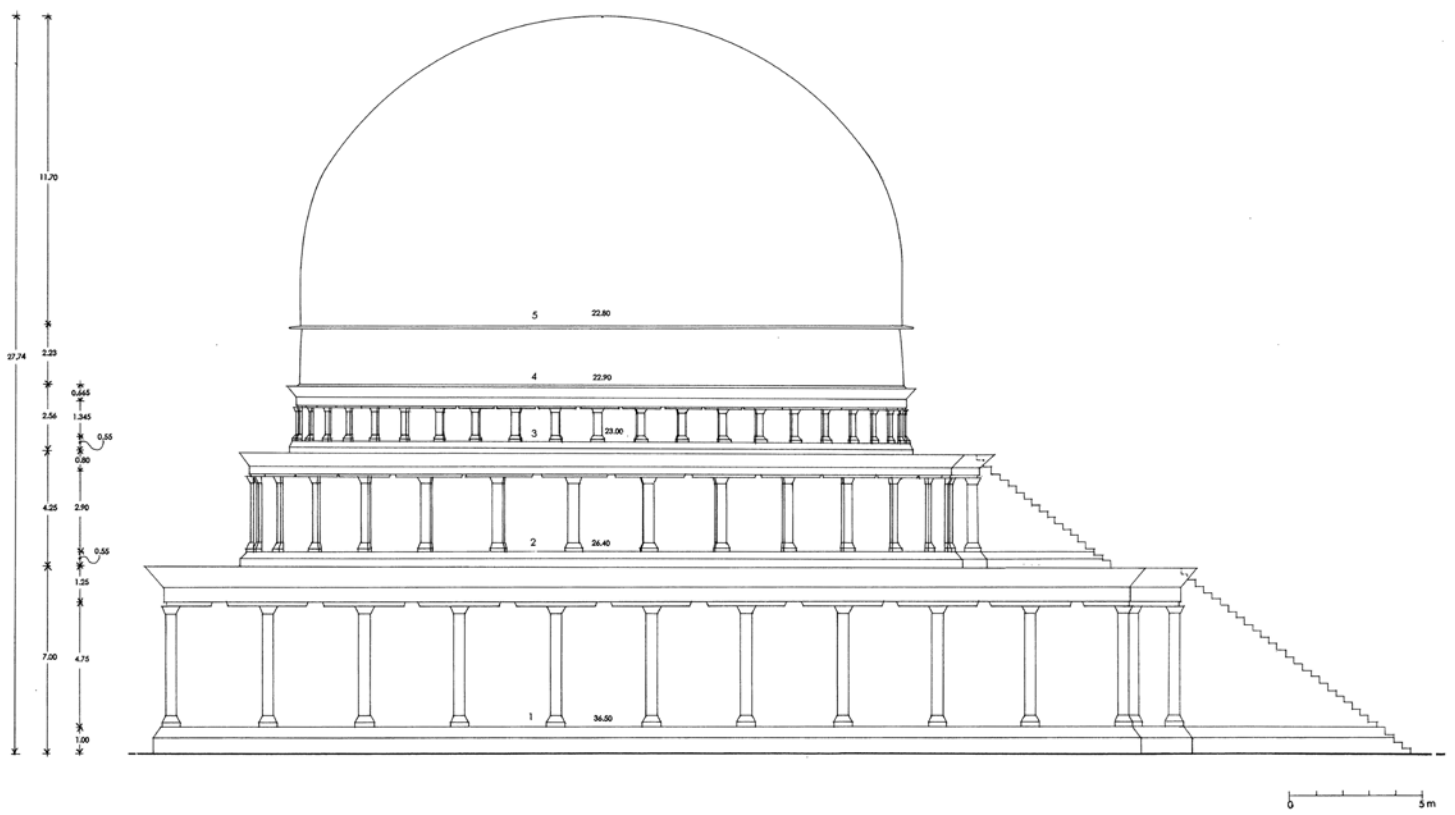

Fig. 155. Stupa of Shankardar. Sketch elevation showing the measures. (Sabelli 1993; Martore 2003).

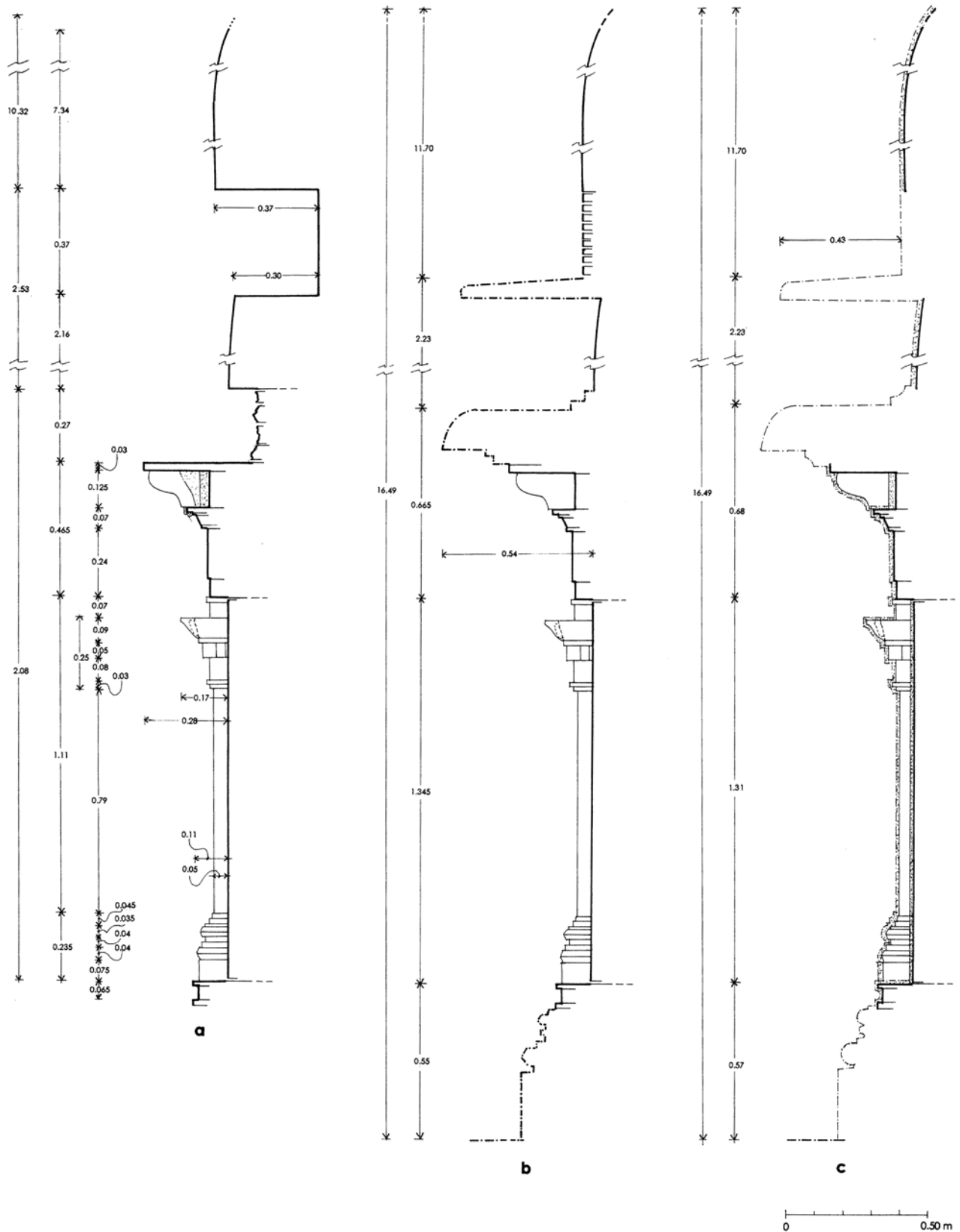

Fig. 156. Stupa of Shankardar. 3rd storey (drum), 4th and 5th storey (composite dome, raised).
 a. profile. b. reconstructed profile, without plaster. c. reconstructed profile, with plaster.
 (Sabelli 1993; Martore 2003).

A. Stupas

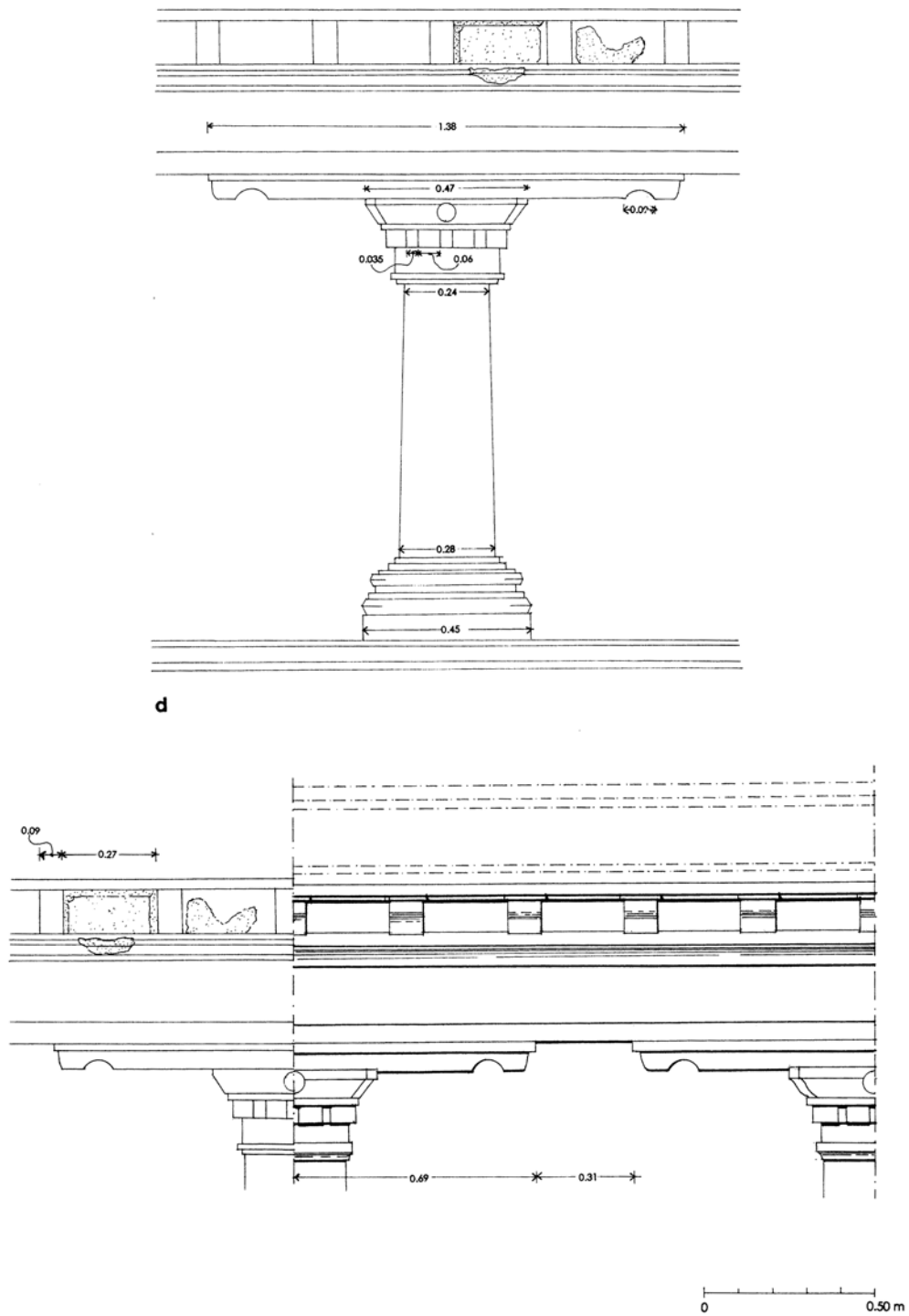

Fig. 157. Stupa of Shankardar. 3rd storey. *d.* pilaster, elevation. *e.* elevation showing the centreline of the pilasters. (Sabelli 1993; Martore 2003).

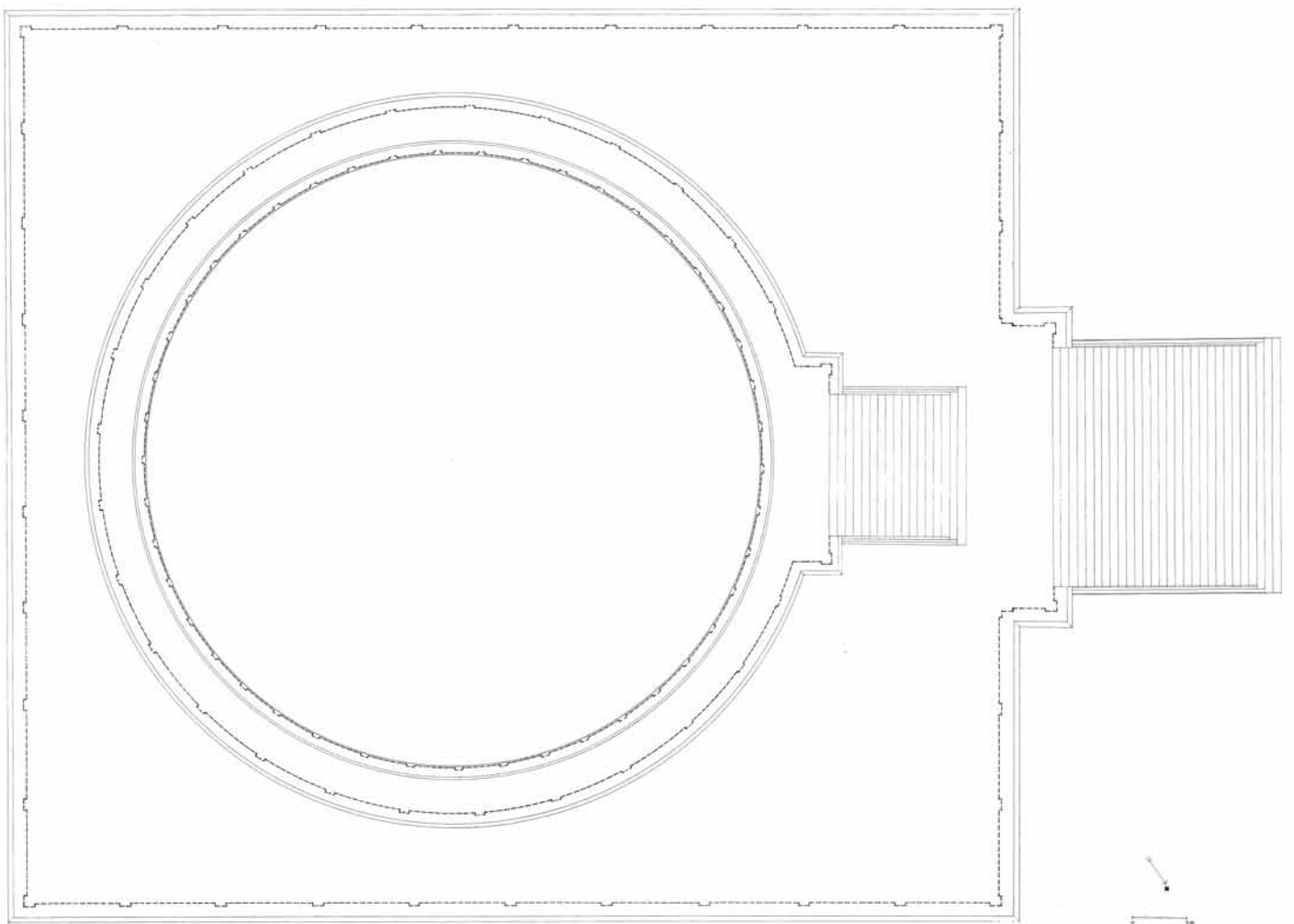

Fig. 158. Stupa of Shankardar. Reconstructed plan. (Sabelli 1993; Martore 2003).

A. Stupas

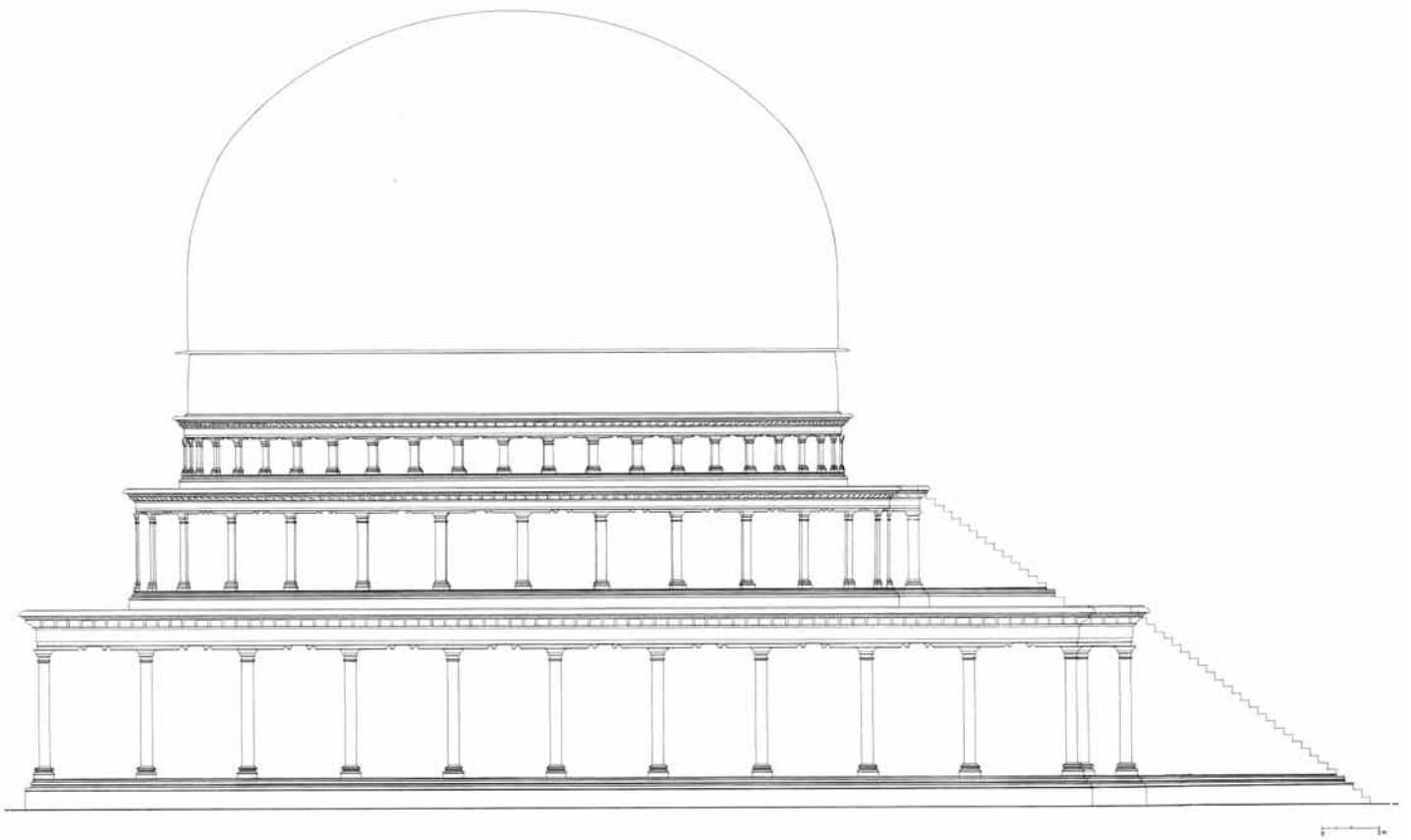

Fig. 159. Stupa of Shankardar. Reconstructed elevation. (Sabelli 1993; Martore 2003).

A9. Stupa of Amluk Dara

(Figs. 160-216)

The Site

Zone of Barikot.

Position: Lat. 34° 38' N; Long. 72° 17' E; SPM 43 B/6.

Coming from Barikot, after leaving the road leading to the Karakar pass, after Nawagai, a (now metalled) road leads off to the left among the fields and the hillside as far as the village of Amluk Dara. Houses have been built among and on top of large boulders, through which flows a rapidly running stream. On a side canal stands a small building, a still fully functioning water mill.

The road narrows to a path among the boulders, runs up the valley and then forks: on the right it leads to a massive stupa in the background; to the left a second valley runs towards Sarbab.

The stupa is situated on a terrace closed to the N by Mt Maran-sar, to the S and E by the steep sides of Mt Ilam, covered with woods interrupted by rock cliffs. On the right, below, runs the stream. Here it takes the name of Materai khwar which lower down becomes the Amluk Dara khwar and lower still, towards the metalled road, Dopsar khwar. East of the stupa, facing Mt Ilam, ruins of monuments appear on the irregular countryside; there is also a stream, the Chinarghichina.

This complex is situated in an important topographic position. It lies near the road linking the Swat Valley to the region of Buner through the Karakar Pass. Furthermore, on the left, towards the E, the road to Ilam leads off; turning northward it joins up with Ghalegai, crossing the Maran-sar and with the Saidu valley through the Sarbab track; the terrain is not particularly difficult.

Bibliography and Documentation

Stein 1929: 32-35, fig. 13 ⁽¹⁾; 1930: 18-19, Figs. 16 (= Stein 1929: fig. 13), 18,

⁽¹⁾ 'Another long day spent in visiting the ruins of a large Buddhist shrine high up in the valley of Amlūk-dara will ever be remembered by me with delight. My visit led me up to the very foot of Mount Ilam, still invested with legendary sanctity, and all the way through charming spring scenery. On the way up I passed at Nawagai a picturesque village nestling around a fine spring which, as ruined walls and terraces in abundance proved, had also served as the centre of an ancient settlement. Copper coins with Greek legends of Bactrian and Indo-Greek rulers and their Indo-Scythian successors, including the great Kushān kings, were brought to me in numbers as soon as the first offerings of this sort had been rewarded with a couple of small nickel pieces. They all had been picked up on the steep hill-sides above, dotted with massive remains of stone-built houses and towers. The chronological evidence that they afforded with regard to a type of ruins so abundant throughout Swāt proved very valuable.

'Then we left the good mule road, much improved by the Bādshāh, leading up to the Karākar pass, which I had first approached in 1898 with a reconnoitring patrol of the Bun'r Field Force. As we turned up a verdant side valley, a brisk little stream, fed by the snow-covered heights of Mount Ilam, refreshed the eye. It made me realize, what one is apt to forget on other far more arid parts of the Frontier, the benefit conferred by water even without the human aid of irrigation. The deep-cut lane along which we travelled was lined with rough hedges showing fine primrose-like flowers in full bloom, and the trees hanging low with their branches, though still bare of leaves, helped somehow to recall Devon lanes. Bluebell-like flowers and other messengers of spring spread brightness over the little terraced fields. At one place they formed what looked like a carpet of worship below a large relievo, carved on a detached rock and showing a seated Buddha. The pious zeal of Pathān invaders — Swāt was occupied by Yusufzai clans only in the fifteenth century — has done what without too much trouble it could to deface the sacred image. Yet this rustic object of worship retained its serenity of head and pose.

'Where the little valley bifurcates close above the hamlet of Amlūk-dara, the steep fir-clad heights of Mount Ilam came into full view, covered with snow well down from its bold pyramid-shaped top. It is sufficiently far from the high snowy ranges that rise above the Swāt valley farther up to offer an impressive sight both from Bun'r and from the middle portion of Swāt. It is easy to understand, therefore, the veneration which it still enjoys among the scattered Hindus of these regions and the superstitious legends with which Pathān imagination invests it. We have merely another illustration of the rule that no conquest nor change of religion can ever efface local worship. Who can tell how far back into antiquity this sanctity of Mount Ilam reaches?

'And just to delight the archaeologist, there rose against this grand background a big Stūpa (fig. 13), of carefully constructed masonry and in more perfect preservation than any I had ever seen. It had not been dug into of old for 'treasure', like all the Stūpas I had so far examined. Nor had the 'Būt' hunter, that destructive agent of modern 'civilizing' influences, been yet at work among the half-dozen decayed mounds marking small Stūpas or shrines on the terraces immediately behind it. The large monument still raises its fine hemispherical dome, about seventy feet in diameter, with its stone facing practically intact, to a height of some forty-eight feet including the circular drum. Together with the customary triple base, the lowest a hundred and thirteen feet square, the whole structure attains a height of close on a hundred feet.

'I can scarcely be mistaken in the belief that, apart from small votive Stūpas, it is probably the best preserved of all the ancient shrines that Indian Buddhist worship has raised over supposed relics of its hallowed founder. Nothing had fallen but the huge circular stone umbrellas that had once belonged to the 'Tee' above the dome. Four of them now lay in a heap on the square base of the Stūpa. The largest of them measures fully fourteen feet in diameter: to raise it to that height must have been a task worthy of some Egyptian builder. Of two copper coins said to have been found at the site one proved to be an issue of the great Kushān dynasty and the other of Turkish Shāhis of Kābul, thus respectively indicating the approximate probable dates when the building was constructed and when worship ceased.

'The survey of this remarkable site, so well chosen by its 'pious founder', naturally took time, and all the while Mount Ilam was gathering fleecy clouds round the bold crags on its head. Soon after we started back the clouds descended from it, and before more than a few miles of the return march had been covered a heavy rain storm broke, accompanied by much thunder and lightning, and drenched us all thoroughly. My escort, however, half a dozen of the Bādshāh's local men-at-arms, were a lusty lot of hardy youths and seemed quite cheerful in spite of their wetting. When regaled by us with tea in camp they let their thin cotton garments dry on their bodies without showing the slightest discomfort'.

pl. 3 above ⁽²⁾.

Barger & Wright (1944) make no mention of it.

Tucci (1958: 315) refers back to Stein and provides two sketches of the stupa, elevation and plan view (figs. 38, 39 and n. 30), made by V. Caroli (1957).

Faccenna 1957: first reconnaissance (and description) of the stupa complex with V. Caroli, who performed the survey.

⁽²⁾ 'Stūpa of Amlūk-dara. On leaving the village which contains about forty homesteads, mainly of Gujars, an imposing Stūpa came into view. It occupies a conspicuous position on high ground close to where the valley bifurcates, one branch running straight up to Mount Ilam and the other to the saddle of Sarbāb on its northern spur. When reached a mile beyond the village and after a total march of about 6 1/2 miles from B^hr-k t, it proved in better preservation than any ancient Stūpa I had ever seen and constructed with remarkably careful masonry (fig. 16, 18). Its secluded position far from any large place or much-frequented route had helped to save it. As the sketch plan and section, pl. 3, show, the Stūpa is raised on a magnificent base 113 feet square and not less than 28 feet high. Above this are placed two circular bases, the lower one together with its plinth being 9 feet high. The drum on which the hemispherical dome rests has a diameter of 71 feet, thus making the Stūpa proper the largest of all I surveyed in Swāt. The drum is divided by a bold cornice supported by brackets at intervals of one foot. A second cornice projecting farther runs below the bottom course of the dome. The latter measures about 46 feet over its curve. Taking into account the conjecturally estimated elevation of the dome the height of the whole structure cannot fall much short of a hundred feet.

'An imposing flight of stairs which appears to have been over 40 feet wide led up on the north side of the square base. From it the top of the first circular base was approached by stairs 12 feet wide. It is only here that the stone facing of the dome and drum is broken for a width of about 15 feet. But the attempt which had evidently been made here to reach the centre and the relic deposit surmised there had not been persevered in, and the relic chamber of the Stūpa may be assumed to be still intact. As shown by fig. 18, the masonry facing of the drum and dome consists of large roughly dressed slabs carefully laid in regular courses. The columns of small dark stones placed laterally between the slabs and the thin layers of similar material dividing the courses exhibit the Gandhāra type of masonry in unusually neat execution. The whole structure must have once borne a solid coating of plaster; for remains of very hard white stucco still cling in places to dome and bases.

A curious feature not observed elsewhere is the presence in the upper cornice of large stone slabs showing semi-circular hollows on their projecting edges. The square base and perhaps also the lower circular base were adorned with flat pilasters projecting about 8 inches. But the columns of small flat stones of which they were composed have crumbled away in most places, leaving only matrices as it were in the wall surface to mark their position. On the eastern side of the square base there lie in a heap four stone 'umbrellas', once raised above the dome, just as they had fallen. Fig. 18 shows them on the right. The largest of them measures 14 feet, the smallest 5 feet 3 inches in diameter. A rectangular slab, 12 feet long, which lies half-buried between them, probably belonged to the member resembling an inverted base which miniature Stūpas from Gandhāra sites usually show between the top of the dome and the succession of Chhatras.

'Remains near large Stūpa — About 50 yards to the east of the great Stūpa a decayed mound marks the position of a small one. Further up, at a distance of circ. 150 yards, four more little mounds are counted within an area about 80 yards square. They, too, probably are the remains of Stūpas. None of these appeared to have been dug into. A much broken mass of masonry is found also near the south-western corner of the large Stūpa base, while on rising ground westwards are scattered ruined walls likely to have belonged to monastic quarters. Of two copper coins brought to me and declared to have been found at the site one was a Kushān issue much effaced and the other piece of the Turkish Shāh[^]s of Kābul. They respectively indicate the approximate periods when worship at the site may have most flourished and when it ceased. Definite chronological indications could be hoped for only from such a systematic exploration as the site owing to its obvious importance and its undisturbed condition invites.

'It deserves to be noted that the valley of Amlūk-dara lies on the route followed by the Hindus of lower Swāt on their annual visit to the sacred heights of Mount Ilam which forms so striking a background to the ruined Stūpa. The top of the mountain was an object of pious pilgrimage already in Buddhist times, as shown by Hsüan-tsang's description of Mount Hi-lo, the identity of which with Ilam I was subsequently able to establish. The site of Amlūk-dara is among all Buddhist sanctuaries I was able to trace certainly the nearest to the sacred peak and may well have been connected in some way with the pious legends which once clustered around it and in a modified form have lingered to the present day'.

In about the same years we have (see Stupa of Shankardar) the visit to Swat made by H.G. Franz who, in addition to the Stupa of Shankardar (Franz 1965: 88, fig. 143) mentions it (erroneously indicating it as the Stupa of Topdara near Haibatgram); 1959: 141, fig. 10 ⁽³⁾; 1965: 88, fig. 142 ⁽⁴⁾; 1977: 138, Figs. 12-13.

Gui and Cimmino 1964: new survey campaign regarding the stupa.

Department of Archaeology and Museums of Pakistan carries out restoration work (Khan, F. A. 1968: 227-28) ⁽⁵⁾.

Franz 1980: 39-40, fig. 2.

Faccenna 1980-1981: 60-61, n. 2; 1993: 304, n. 1.

Sabelli 1993: new survey of the stupa with the collaboration of Anna Mannari and Fabio Mosca; carried out in the zone of the 4th pilaster, starting from the N, on the W side a small sondage to determine mouldings and height of the base of the 1st storey.

Photographic campaigns were carried out at various times, during inspections and visits by several Italian Archaeological Mission members and guests:

Faccenna 1957, 1976; Callieri 1979; Olivieri 1989; Nascari 1993.

Khan M. Ashraf 1993: 62-63, pl. XV, fig. 48.

Kuwayama 1993.

Olivieri and Spagnesi 2005.

⁽³⁾ 'Eine ganze Anzahl von Stupas dieses Typus hat sich im Swat-Tal, dem alten Uddayana, erhalten. Sie haben einen großen quadratischen Unterbau mit Pilastern, im Stupa von Topdara über Haibatgram noch erhalten (Abb. 10), und darüber steigt der Stüpa zylinder in Proportionen auf, die den klassischen der Modellstüpas von Taxila-Sirkap entsprechen (Abb. 4)'.

⁽⁴⁾ 'Eine Anzahl von monumentalen Stupas dieses Typus hat sich, imposant gelegen, im Swat-Tal, dem alten Uddayana, einem Hochgebirgstal, erhalten. Am Stupa von Topdara über Haibatgram [wrongly for Amlukdara] ist der quadratische unterbau mit Pilastern noch sichtbar'.

The two figures (10 and 142), showing a view of the E side, differ slightly in that fig. 10 is shifted slightly leftwards with respect to fig. 142.

Figure 142 is reported in Franz 1977: 138, fig. 12, together with fig. 13 reproducing the sketch in Tucci 1958: fig. 38.

⁽⁵⁾ 'Amlokdara stupa. The colossal stupa situated in the picturesque valley of Amlokdara, about 20 miles south-east of Saidu Sharif, on the Saidu Pirbaba road, is the largest stupa in Swat. It is built in carefully constructed masonry, raised on a significant base, 113 feet square, and not less than 28 feet high. Above this are placed two circular bases, the lower with its plinth 9 feet high. The drum on which rests the hemispherical dome has a diameter of 71 feet. The drum is divided by a bold cornice supported by brackets at intervals of one foot. A second cornice projecting further, runs below the bottom course of the dome. The square base is approached from the north by an imposing flight of steps over 40 feet wide. The first circular base is approached by steps 12 feet wide.

'The masonry facing the drum and the dome consists of large roughly dressed slabs carefully laid in regular courses. Remains of hard white stucco still cling to the dome and the base, indicating that the whole structure was originally plastered. The height of the structure has been estimated at about a hundred feet.

'The stupa has suffered a lot during the past and its plinth and platform are both in a dilapidated condition. There is a breach in the dome, and the masonry is missing in several places in the plinth at the platform. General clearance of the site and petty repairs to the masonry were carried out. The work was started with the restoration of the plinth and platform on the north-east and east sides. The restoration was carried out in masonry between rubble and diaper pattern, similar to the original. The breach in the dome was also filled in with rubble masonry. Although the repairs were carried out in cement mortar, every effort was made to keep the mortar invisible from the outside. The entire area surrounding the stupa was also made neat and tidy'.

Olivieri 2006: Archaeological Map of the Swat Valley (Olivieri & Vidale 2006; Spagnesi 2006: 163, 170, fig. 24).

The Stupa

The stupa is built on a substruction platform which is needed to offset irregularities in the terrain, probably a terrace with steep sides on the S and to a lesser extent to the E. The substruction walls are visible to the S up to a height of c. 3.00, to the E, with the height decreasing in a northward direction, to the W in the final section to the S, while to the N the grade plane seems to meet the original ground level. The wall projects c. 1.00 out from the base of the monument. The walls reveal the core made up of large and small schist slabs bonded by earth; there are no traces of the probable plaster coating.

The stupa is the largest in the region and extremely well conserved. It comprises a 1st storey, quadrangular in plan, a 2nd storey, cylindrical and set back, both decorated with pilasters, a cylindrical 3rd storey, the drum, set even further back, and then, having the same diameter, the composite dome with the 4th and 5th storey. It has some flights of steps facing N along the same axis corresponding to the 1st and 2nd storey, at the top of which, abutting the 3rd storey, is the base of a probable niche (cf. Tokar Dara). The facing of the 1st storey is missing on the S and E sides, and partly on the W side; thus part of the 2nd storey; a gap opens above the base on the 3rd and 4th storeys; on the 3rd storey penetrates as far as the core (now used to store hay); all the pilasters and cornices above this are missing; the stairways of the 1st and 2nd storeys are in ruins. Since 1957, the year of our first visit, the stupa has not suffered any further substantial damage. The Department of Archaeology and Museums carried out restoration work in the years before 1968 involving the partial repair of the 2nd storey wall, of the niche base and the partial closure of the latter.

The facing is composed of larger blocks at the lower level, which grow smaller as the level rises, accurately dressed, laid in regular rows, very closely spaced, with the gaps between them filled on all four sides of the block by thin regularly cut slabs. The material consists of fine-grained gneiss for the blocks, dark schist for the thin slabs. The core is made of gneiss blocks, schist slabs, closely spaced and well bonded, and of small sized materials; solidly bonded using earth.

1st Storey, Quadrangular in Plan

It is 6.97 tall, with the sides measuring 34.55 to the W, 34.60 to the E, 32.37 to the N, 32.42 to the S. It is decorated with pilasters; it has a stairway with a northward projection. The torus type base has a profile that can no longer be determined accurately owing to corrosion. On the high plinth there is a torus and

thus three moulding elements, each obtained from a block of gneiss: the first may be considered a filleted cavetto, the remaining two, superimposed, corroded and cambered, corresponding to a low set-back fillet and a rounded projecting slab(?); the base of the pilaster springs from the latter.

In the small sondage opened at the height of the 4th pilaster, starting from the N, on the W side, a paving slab was found and used as the starting point for measuring height. At the level of the cavetto the base is closed with chips and small slabs forming a short shelf, held together by thick plaster which descends the plinth wall as far as the base springer; it was probable repair work or meant to provide a level surface on which to place some decoration.

What is left of the pilasters are the empty spaces; h. 4.10 from above the base as far as the beginning of the capital; hypothetical h. of the base 0.30, calculated on that of the 2nd storey; shaft h. 3.80, width 0.30 with 0.04 projection. Of the capitals a few initial slabs have been conserved and in one case, in pilaster 5 counting from the N on the W side, there are several slabs, perhaps of the abacus and above this several superimposed slabs of the cornice; all the rest has been lost. An exception to this is the inner corner capital on the W side of the stairway projection, which is still conserved although badly corroded. Above the initial schist slabs and several thin slabs lies the capital composed of three gradually projecting superimposed limestone blocks (from 0.03 at the bottom, to 0.11 half way up, to 0.20 at the top) and ending in a fourth block above, and ultimately closed by a schist slab forming the abacus. This conserves part of the petals of the central projecting rosette. The abacus displays a recess in the right hand block which has two projecting schist fillets below it. The capital forms an angle with the other adjoining half. Obviously the plaster coating completed the profile and the decoration. The height of the capital may be estimated as c. 0.60.

There are 15 pilasters, including the corner ones, with an interaxis of 2.50, which are not all exactly the same. The cornice shape is hypothetical and is proposed on the basis of comparisons with what appears in the 4th storey, in the absence of the 2nd and 3rd (6).

The stairway is partially conserved and buried; the following are visible: part of the outer W corner and of the E wall of the projection and a short section of the smooth W wall of the flight of steps; the projection has pilasters in the inner and outer corners and a half pilaster where it joins the ramp; it must have had 27 steps with an inclination of 40°.

(6) The base of the pilaster is adjusted to that of the 2nd storey. The existence of brackets and the absence of modillion on the pilaster capital are uncertain. In the case of the modillion there do not appear to be any elements or gaps to justify it.

2nd Storey, Circular in Plan

Set back by 5.30 on the S side and by 4.75, 4.80 on the W and E sides, 3.76 tall, with diam. of 22.90 at the wall, decorated with pilasters of which the sockets remain. It shows signs of widespread restoration work on the E side in the lower part of the storey. The base follows the profile of that of the 1st storey; h. 0.65, projections 0.36. It has a plinth made of normal and small slabs, a three-sided bevelled torus, cavetto, set back fillet and tapering projecting fillet (?), each of which obtained from a block of gneiss. The latter supports the base of the pilaster, composed of a plinth, obtained from a block of gneiss, and on top small superimposed schist slabs which form a scotia, double torus and cavetto (three slabs): h. 0.245; profile not conserved, corroded, but reconstructed. The shaft, 0.30 wide and projecting by 0.03 is made of small superimposed blocks alternating with rows of small schist slabs. The capital and the cornice of the body have not been conserved and are hypothesized on the basis of the motifs described in the 1st storey and thus reported here. The pilasters number 31 with an interaxis of 2.07, not exactly of the same size. The facing technique involved small blocks (seven rows) with the regular insertion of small slabs.

The base continues on to the projection of the stairway and the side of the ramp, which has no pilasters, projecting by 0.22.

The pilasters continue on to the projection, in both the inner and outer corner, with only one side joining the ramp. The stairway has been largely lost or buried; it may be reconstructed as having 14 steps and an inclination of 40°.

3rd Storey, Circular in Plan (Drum)

Set back by 2.30, 2.53 tall, with a diam. of 18.30 at the wall, with a base, cornice and smooth wall with six rows of blocks. The base is supported by projecting foundation slabs with a small wall meant to be visible; the mouldings are badly corroded but may be reconstructed following the scheme of the 2nd storey base: plinth, torus, cavetto, set back fillet and a projecting one above on which the wall is supported.

The cornice may be reconstructed as having a cavetto and ovolo profile, brackets and reverse ovolo; it lacks coping slabs. Each element is obtained from a schist or gneiss slab; in some sections the ovolo consists of more than one superimposed schist slab; the brackets are made of a block of gneiss with a reverse cavetto profile??. Where the ovolo consists of several slabs, the brackets are made using superimposed small slabs, eight or nine in number. The bracket spacers consist of superimposed small slabs, closed at the front by a vertical slab. A very thick plaster coating (c. 0.05) is laid over the latter; subsequently, several successive coatings of

plaster were applied to the side walls as well as to the upper and lower ones; traces of the join between the layers and the first coating are visible.

In front of the point where the stairway reaches the 3rd storey, against the wall of the latter a base with a rectilinear front abuts (or is joined); this base, 4.00 wide, has been restored and has a projection of 0.90; there remains part of the wall with a badly eroded moulded base, probably a continuation of that of the storey, as may be inferred from the overall measures and those of the plinth; the overhand of the base is smaller (0.13); it has been extensively restored. Above this a gap opens in the masonry which narrows as it rises as far as half way up the dome. It is therefore not possible to determine the upper part of the base and the structure above, probably a niche.

4th and 5th Storey (Composite Dome)

4th Storey, Circular in Plan, Transition Element

Slightly set back, it has one or two rows of projecting blocks at the base; obviously for leveling purposes or for some other construction reason; it lacks any architectural value as it does not represent a base moulding. The smooth wall presents seven rows of isodomic blocks (0.70 x 0.30), growing smaller towards the top and separated by two rows of thin schist slabs; at the sides of the blocks, the slabs are superimposed, carefully dressed to fit the irregularities in the roundish cuts of the latter. The wall is slightly curved and re-entrant at the top.

The cornice comprises a bracket with cyma reversa and above this three rows of slabs that progressively project to form an ovolo between two fillets at different heights, the lower one being larger.

5th Storey, Raised Dome

On the cornice, which like the one below it also lacks coping slabs, the raised dome begins. At its base parallelepiped shaped blocks are laid edgewise and project beyond the cornice plumb, separated by parallelepiped shaped blocks of slightly lower height, laid lengthwise, which have a slightly set back plumb line with respect to the underlying wall of the storey. The blocks (h. 0.18, leng. 0.45-0.75) display one, and sometimes two, rectangular recesses in the upper part. These blocks were apparently closed in front by flat laid slabs. Traces of plaster coating remain. The function of this structure, cited by Stein who defines it as 'a curious feature not observed elsewhere'; indeed it is not clear; it was probably related to the construction phase of the dome and the erection of the disks, using the projecting blocks and recesses to support a scaffolding.

This row of parallelepiped shaped blocks above the 4th storey cornice, flush with the front of the slab face and slightly set back with respect to the edge of the 4th storey wall, marks the starting point of the dome, which has an initially vertical direction before curving into a semi-circle. It has been conserved almost intact except in the N part, which is interrupted by a gap starting from the 3rd storey above the base that now tapers until it ends. The outer surface has been conserved up to a h. of 7.98 and with the core practically continues as far the the top of the curved part; it has a diam. of 17.96.

Chattravali Elements

Chattravali elements lie on the upper plane of the 1st storey, to the N and NE. These were observed and measured by Faccenna in 1957:

1 – large disk, the biggest one, with sloping edge; diam. 4.16 (radius 2.08 at centre of perforation) with a blind central hole with a diam. 0.09 and depth 0.16, thickn. 0.33 (Stein 1930: 19) (7);

2 and 3 - below, two other disks of smaller diam.;

4 – another of diam. 2.00, with eccentric socket; no perforation;

5 – an identical one without perforation;

6 – another element with a straight side, visible over a length of 2.50, thickn. 0.23.

Stein (1930: 19, figs. 16, 18) observed a pile of four umbrellas (fig. 18 on right). The largest one is 14 ft., the smallest 5 ft. 3 in. in diam.; the latter include a rectangular slab, 12 ft. long, probably part of a harmika.

The comparison among the situations described by Stein 1930, Faccenna 1957, in the sketches by Gui and Cimmino 1965 reveals a certain shifting of the items with respect to the present situation, as described in Sabelli and Faccenna 1993. One reference point is no. 1. In the 1993 plan view a small disk appears beside no. 1; another is shown below this, respectively marked as nos. 2 and 3. In front of the stairway of the 2nd storey there is another, badly conserved, unperforated disk, marked as no. 4 (perhaps the no. 5 of 1957), which are probably parts of the pinnacle structure.

⁽⁷⁾ Faccenna 1980-81: 60-61, n. 2; 1993: 304, n. 1.

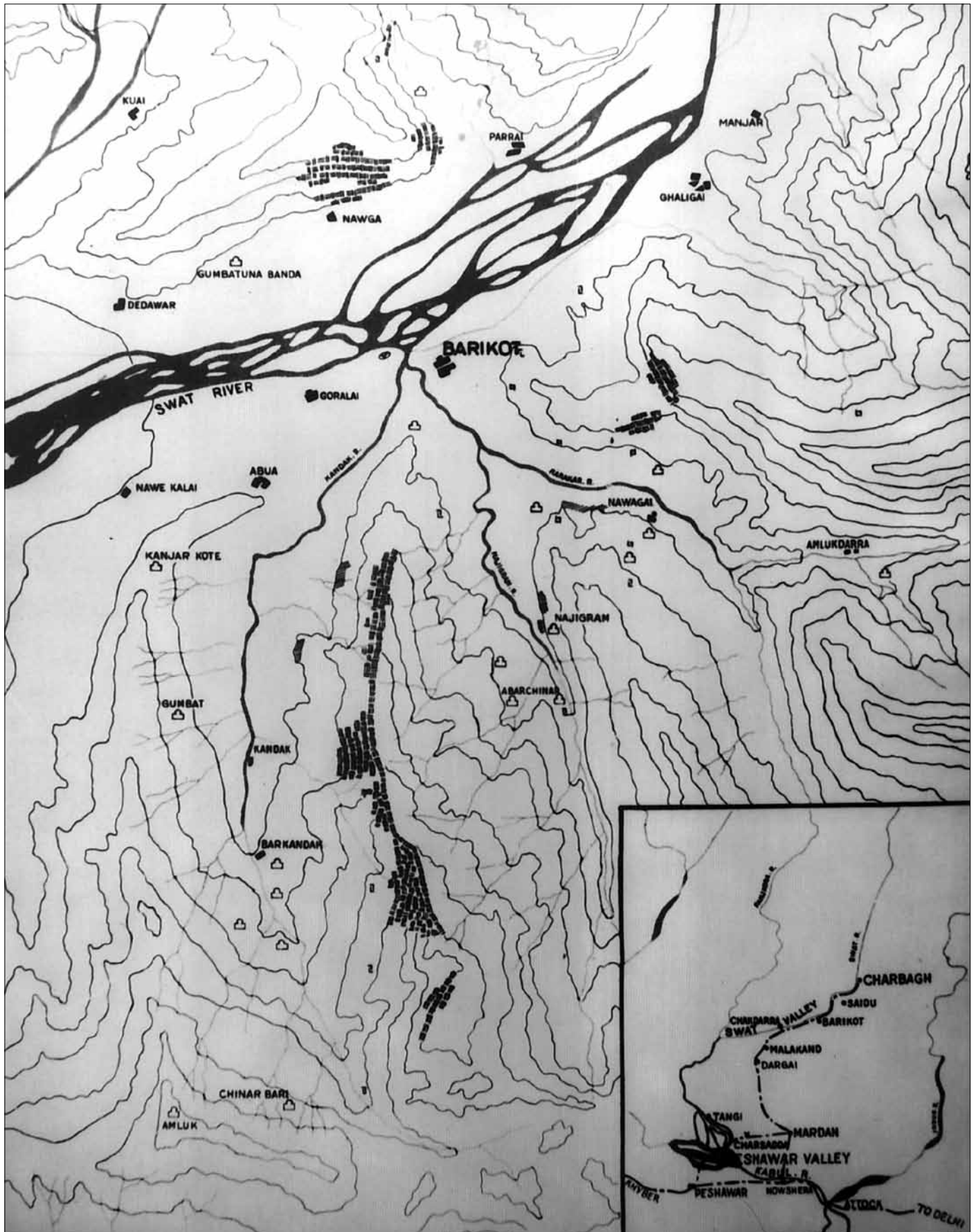

Fig. 160. Sketch map of the zone of Barikot. (After Barger & Wright 1941: tav. XII).

A. Stupas



Fig. 161. Stupa of Amluk Dara. General view from S-E. (After Stein 1930: fig. 18 [=Stein 1929: fig. 13]).



Fig. 162. Stupa of Amluk Dara. E side. (After Stein 1930: fig. 16).

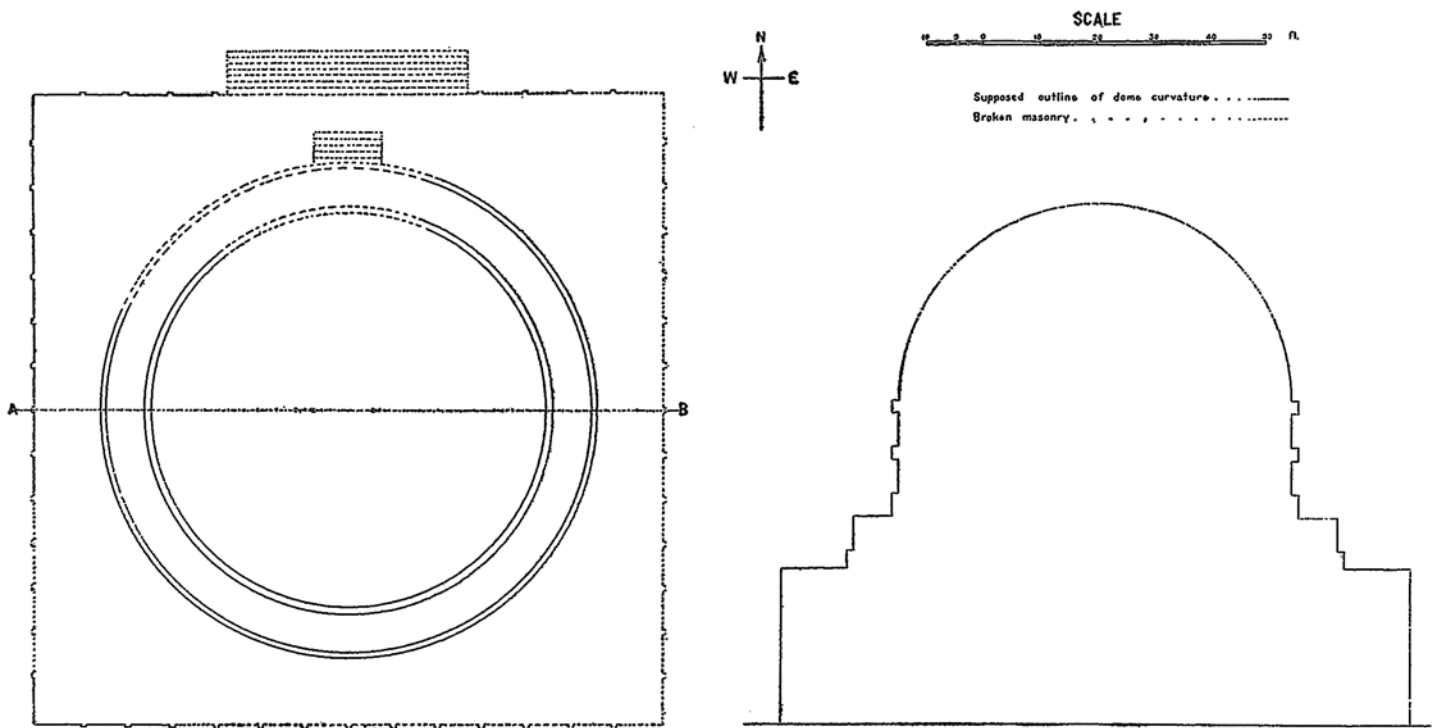

Fig. 163. Stupa of Amluk Dara. Sketch plan and elevation. (After Stein 1930: pl. 3 at the bottom).

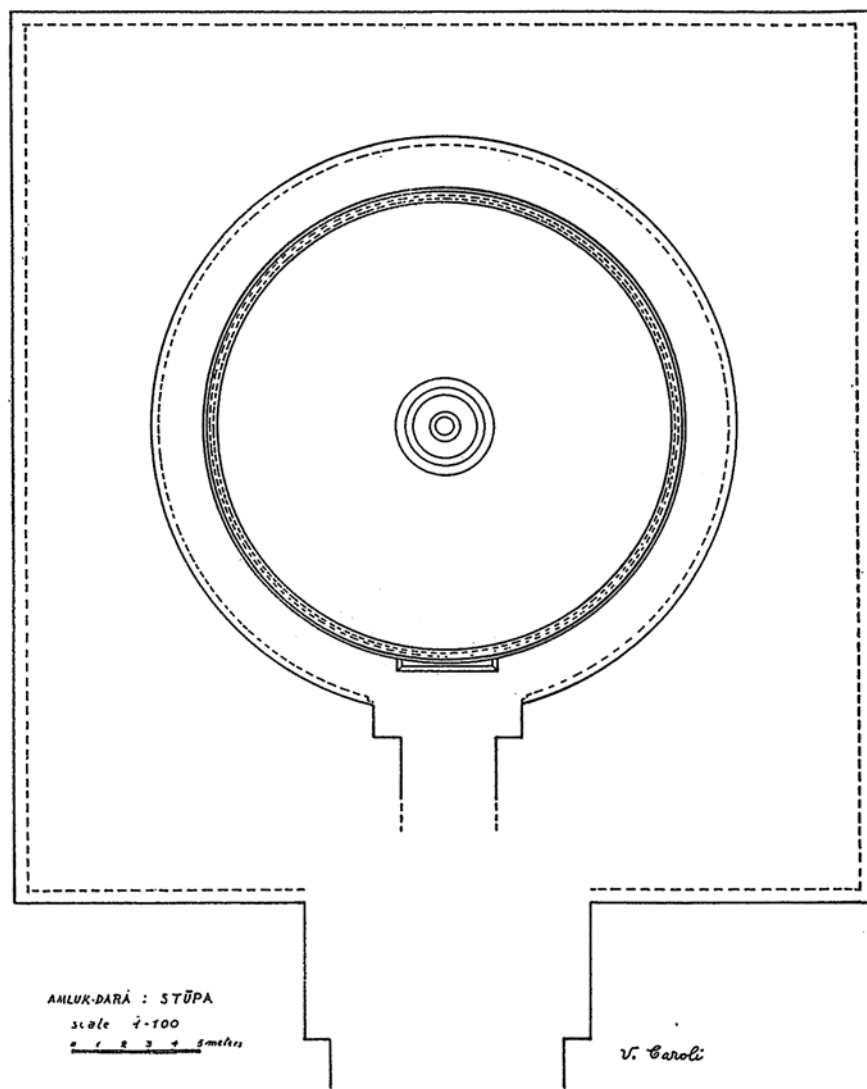

Fig. 164. Stupa of Amluk Dara. Plan. (After Tucci 1958: fig. 39; drawings by Caroli).

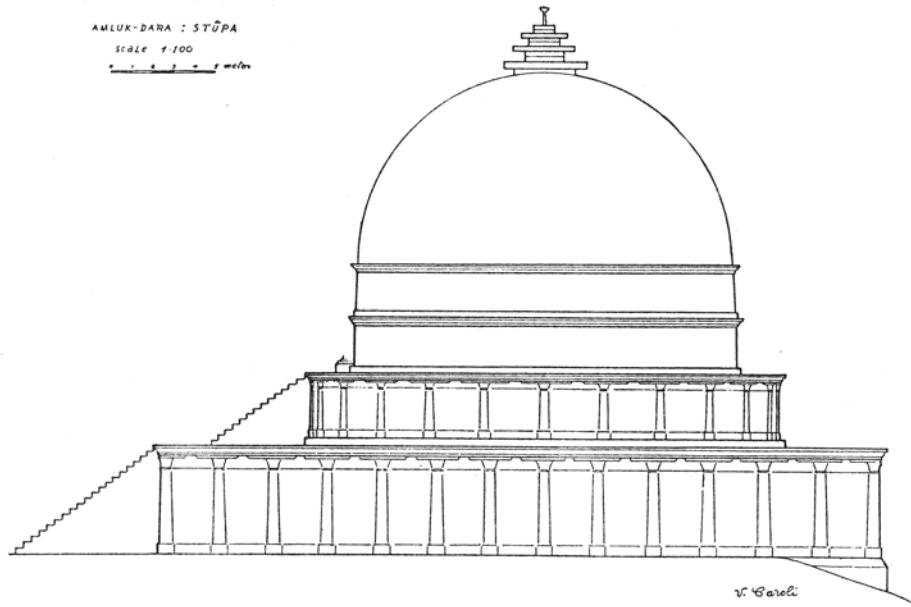

Fig. 165. Stupa of Amluk Dara. Elevation. (After Tucci 1958: fig. 38; drawings by Caroli).

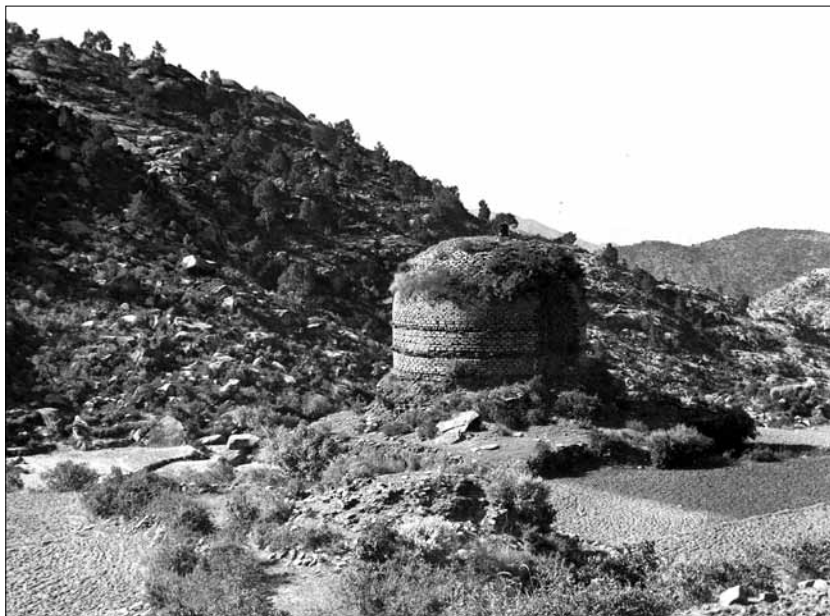

Fig. 166. Stupa of Amluk Dara. General view from NE. (Taddei 1957; Neg. CS).

A. Stupas



Fig. 167. Stupa of Amluk Dara. 2nd storey. N side. Stairway, E side. (Taddei 1957; Neg. CS).

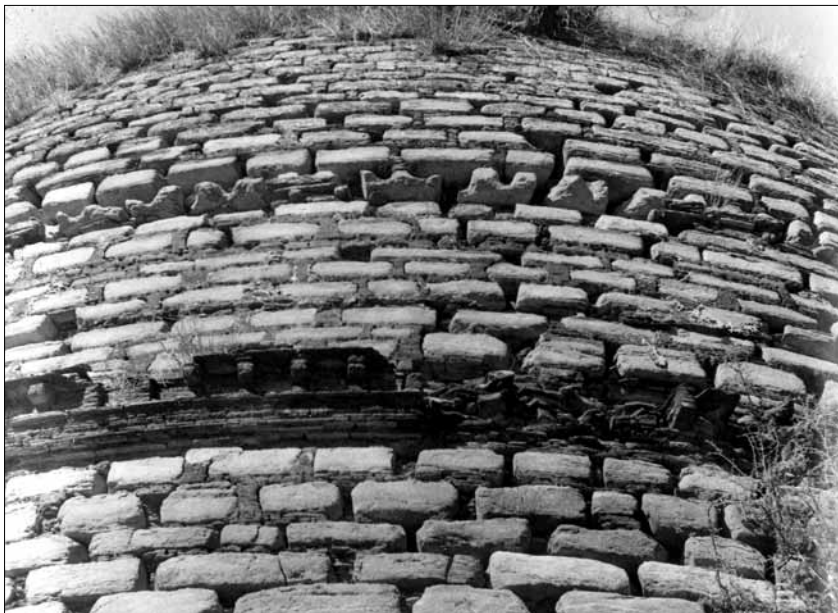

Fig. 168. Stupa of Amluk Dara. 3rd, 4th, 5th storey. NE side. (Taddei 1957; Neg. CS).



Fig. 169. Stupa of Amluk Dara. 3rd storey, detail of the cornice, W side. (Taddei 1957; Neg. CS).



Fig. 170. Stupa of Amluk Dara. E side. (After Franz 1965: fig. 142).

A. Stupas



Fig. 171. Stupa of Amluk Dara. General view of W and N sides showing the stairway and the gap on the wall of the dome. (Sabelli 1993).



Fig. 172. Stupa of Amluk Dara. General view of the N side showing the stairway. (Spagnesi 2005).

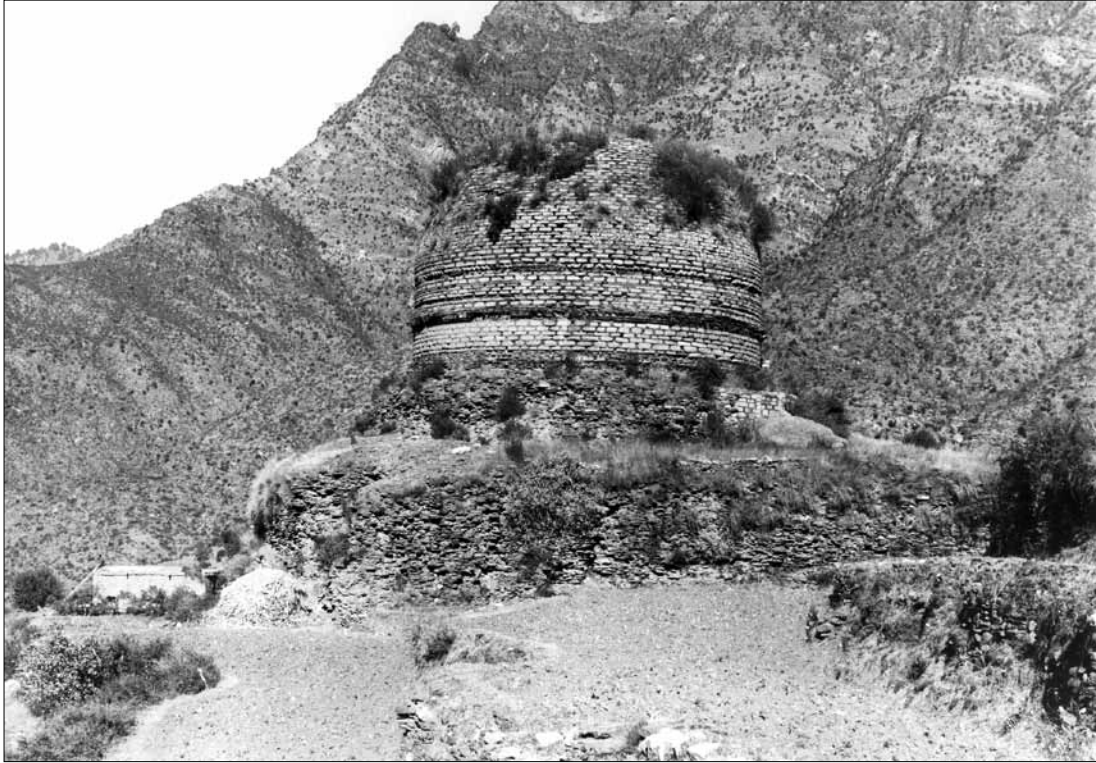

Fig. 173. Stupa of Amluk Dara. General view of the S side. (Faccenna 1976; Neg. CS).



Fig. 174. Stupa of Amluk Dara. General view of the NE side. (Spagnesi 2005).



Fig. 175. Stupa of Amluk Dara. 1st storey. W side, 4th pilaster from N, base of the 1st storey. (Sabelli 1993).



Fig. 176. Stupa of Amluk Dara. 1st storey. W side, 5th pilaster from N, top of the shaft and several elements of the capital. (Sabelli 1993).



Fig. 177. Stupa of Amluk Dara. 1st storey. N side. Stairway, E side, inner corner pilaster of the stairway and storey. (Sabelli 1993).



Fig. 178. Stupa of Amluk Dara. 1st storey. N side. Stairway, E side; detail of the capital of the inner pilaster of the storey.

A. Stupas



Fig. 179. Stupa of Amluk Dara. 2nd storey. NW side; restored. (Kuwayama 1993).

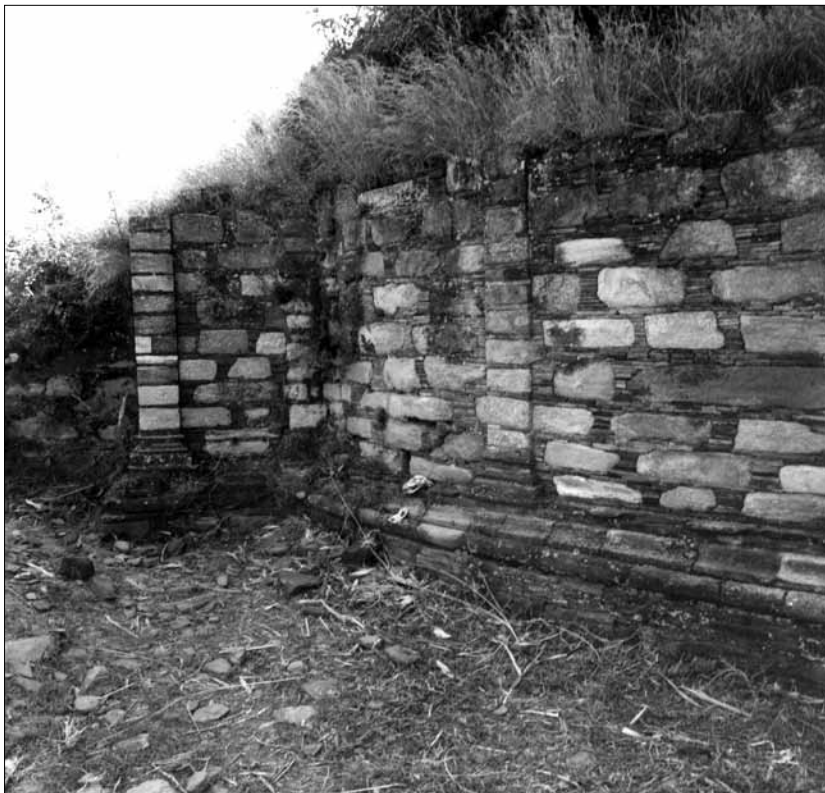

Fig. 180. Stupa of Amluk Dara. 2nd storey with the stairway projection, W side; restored. (Kuwayama 1993).



Fig. 181. Stupa of Amluk Dara. 3rd storey (drum) with base (missing) and cornice with brackets (four of them have been conserved) and 4th transition storey of the composite dome. (Kuwayama 1993).



Fig. 182. Stupa of Amluk Dara. 3rd storey (drum), cornice (the same stretch) with view from W. (Spagnesi 2005).



Fig. 183. Stupa of Amluk Dara. 3rd storey (drum), cornice; detail showing brackets and plaster. (Spagnesi 2005).



Fig. 184. Stupa of Amluk Dara. 3rd storey (drum), cornice, view of the profile on the W. Above, springer of the 4th transition storey, with projecting slabs. (Nascari 1993; Neg. CS).



Fig. 185.
Stupa of
Amluk Dara.
3rd storey. N
side. Base
(of niche?),
W side;
restored.
(Nascari
1993; Neg.
CS).



Fig. 186. Stupa of Amluk Dara.
3rd storey. N side. 2nd storey, 3rd
storey with base (of niche?), E
side; restored. (Faccenna 1976;
Neg. CS).

A. Stupas



Fig. 187. Stupa of Amluk Dara. 3rd-5th storey. NE side. (Faccenna 1976; Neg. CS).



Fig. 188. Stupa of Amluk Dara. 3rd-5th storey. W side on the right of the gap. (Kuwayama 1993).

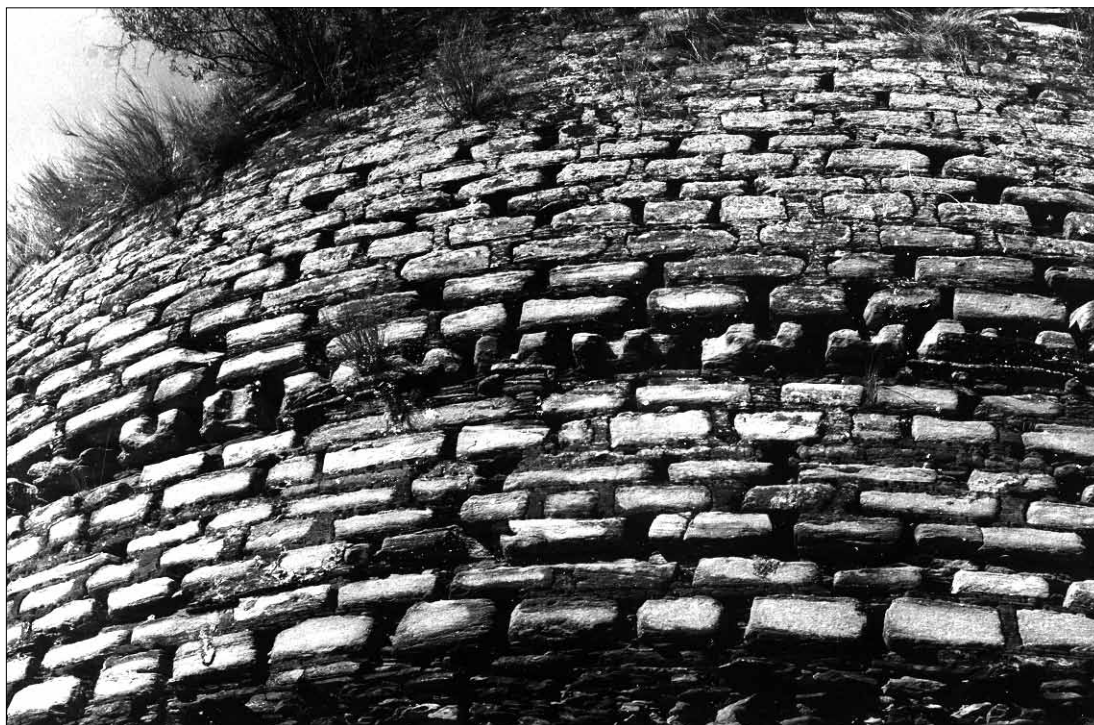

Fig. 189. Stupa of Amluk Dara. 3rd-5th storey. (Faccenna 1976; Neg. CS).

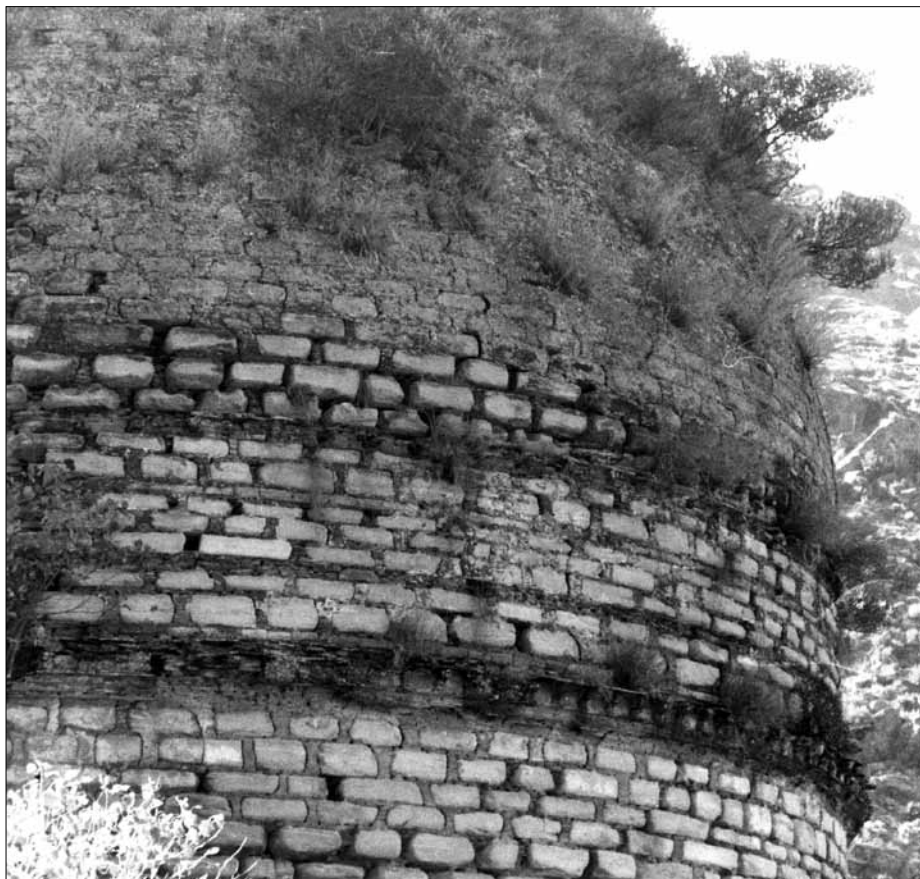

Fig. 190.
Stupa of
Amluk
Dara. 3rd-
5th storey.
(Sabelli
1993).

A. Stupas



Fig. 191. Stupa of Amluk Dara. 5th storey. W side, with cornices. (Kuwayama 1993).



Fig. 192. Stupa of Amluk Dara. 4th and 5th storey. Side with intermediate cornices. (Nascari 1993; Neg. CS).



Fig. 193. Stupa of Amluk Dara. Disk no. 1; beside, supported by the wall of the 2nd storey, there is disk no. 2. (Spagnesi 2005).



Fig. 194. Stupa of Amluk Dara. Disk no. 4; in front of the stairway of the 2nd storey. (Sabelli 1993).

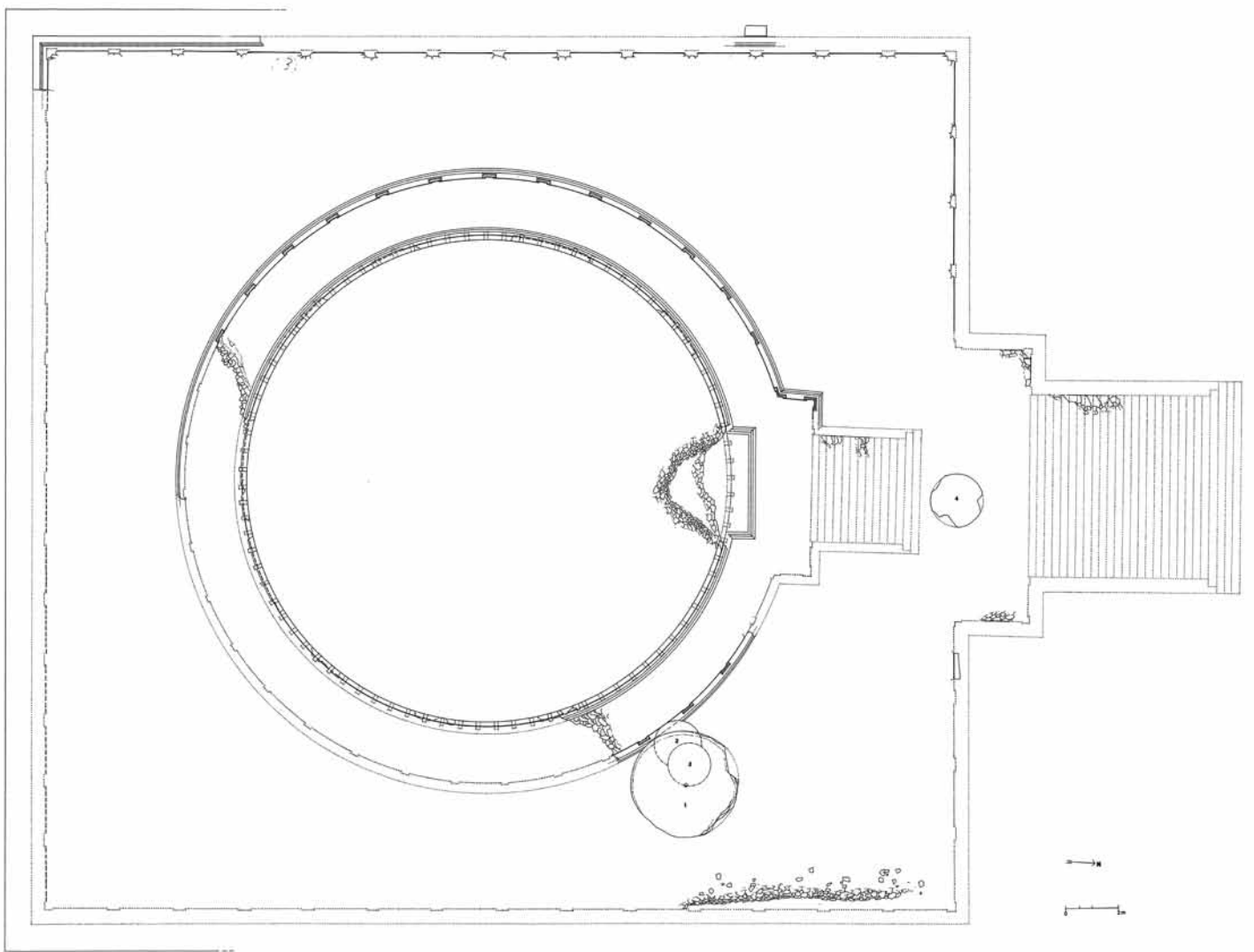

Fig. 195. Stupa of Amluk Dara. Plan. (Sabelli 1993; Martore 2004).

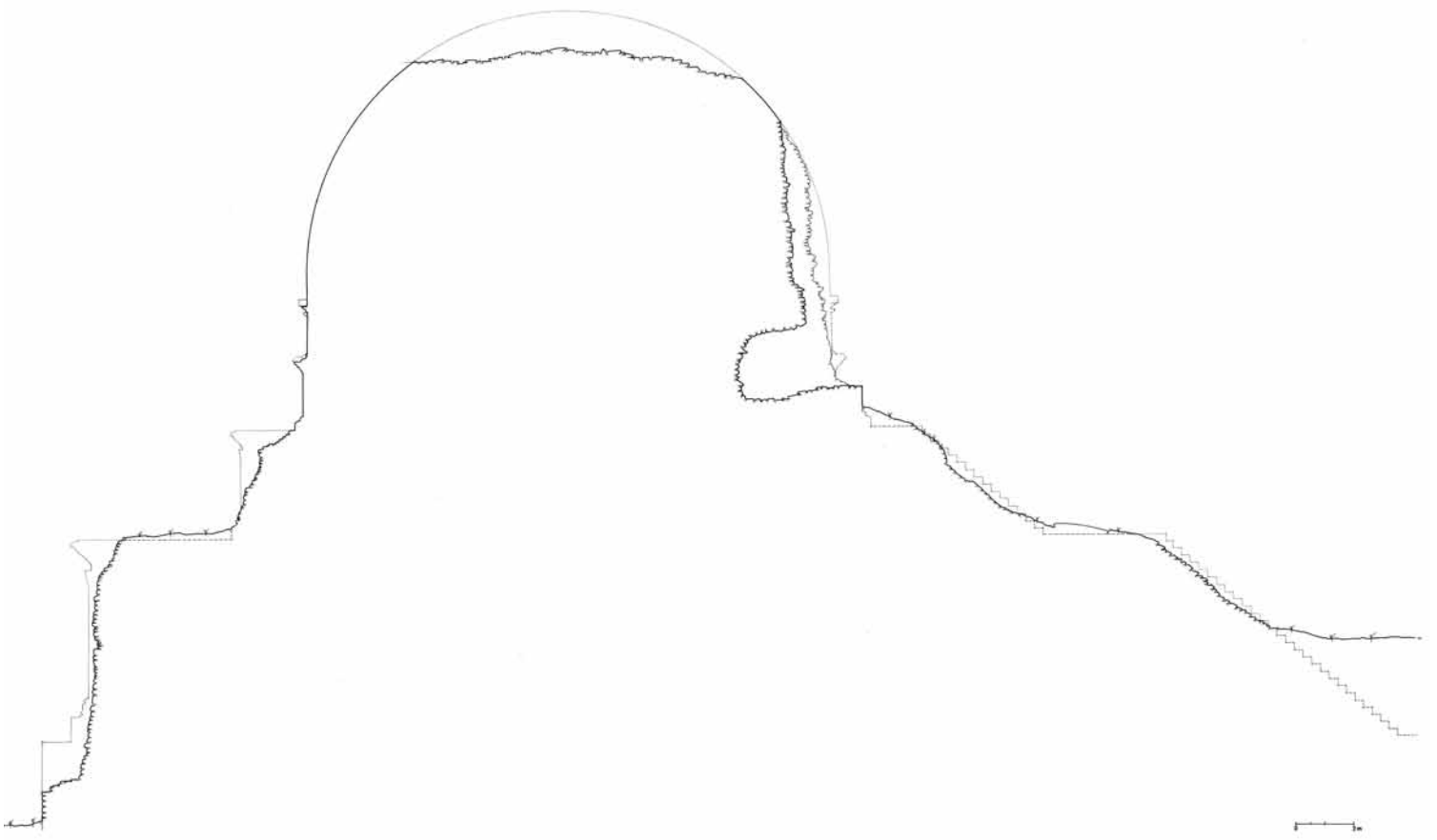

Fig. 196. Stupa of Amluk Dara. N-S cross section. (Sabelli 1993; Martore 2004).

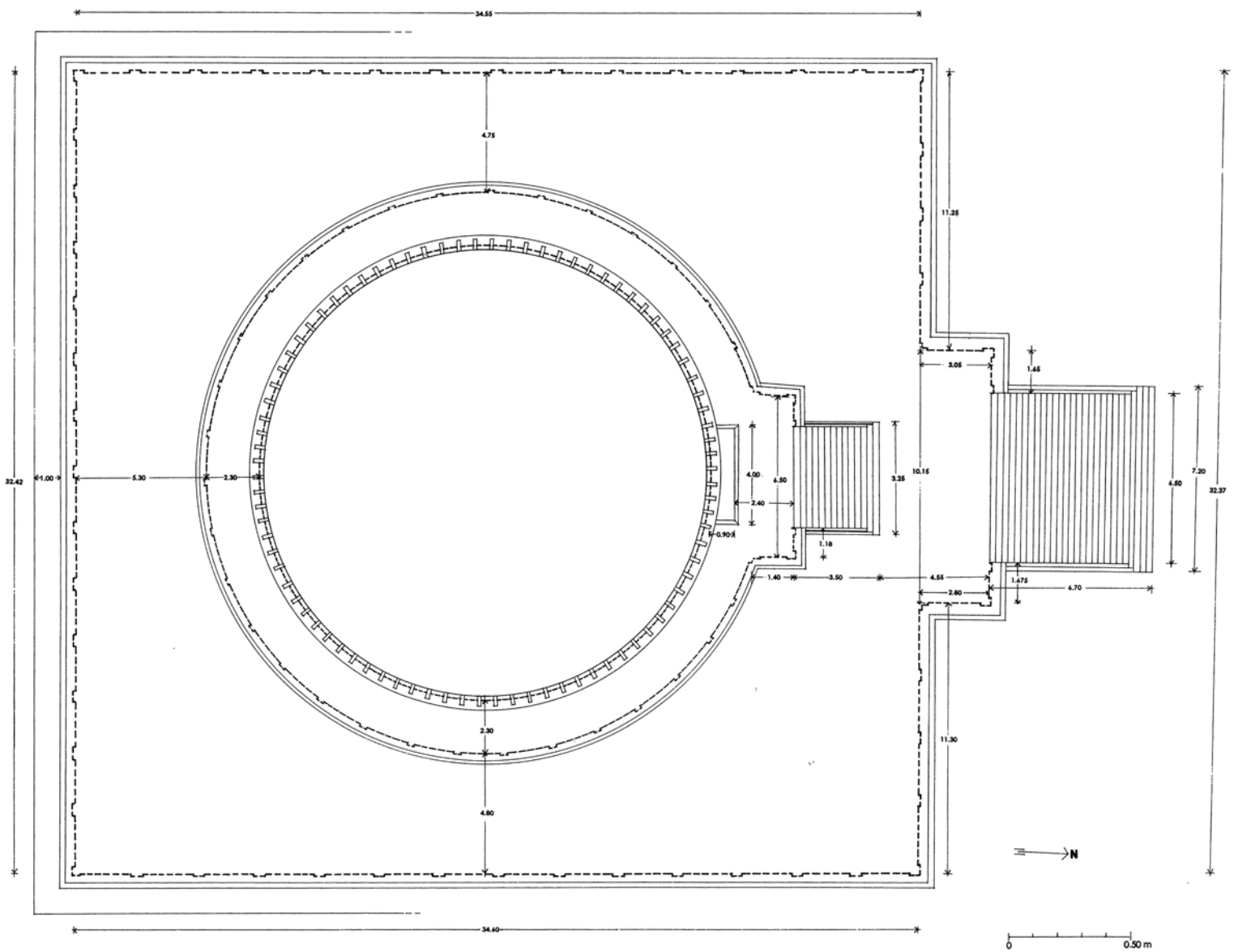

Fig. 197. Stupa of Amluk Dara. Sketch plan showing the measures.
(Sabelli 1993; Martore 2004).

A. Stupas

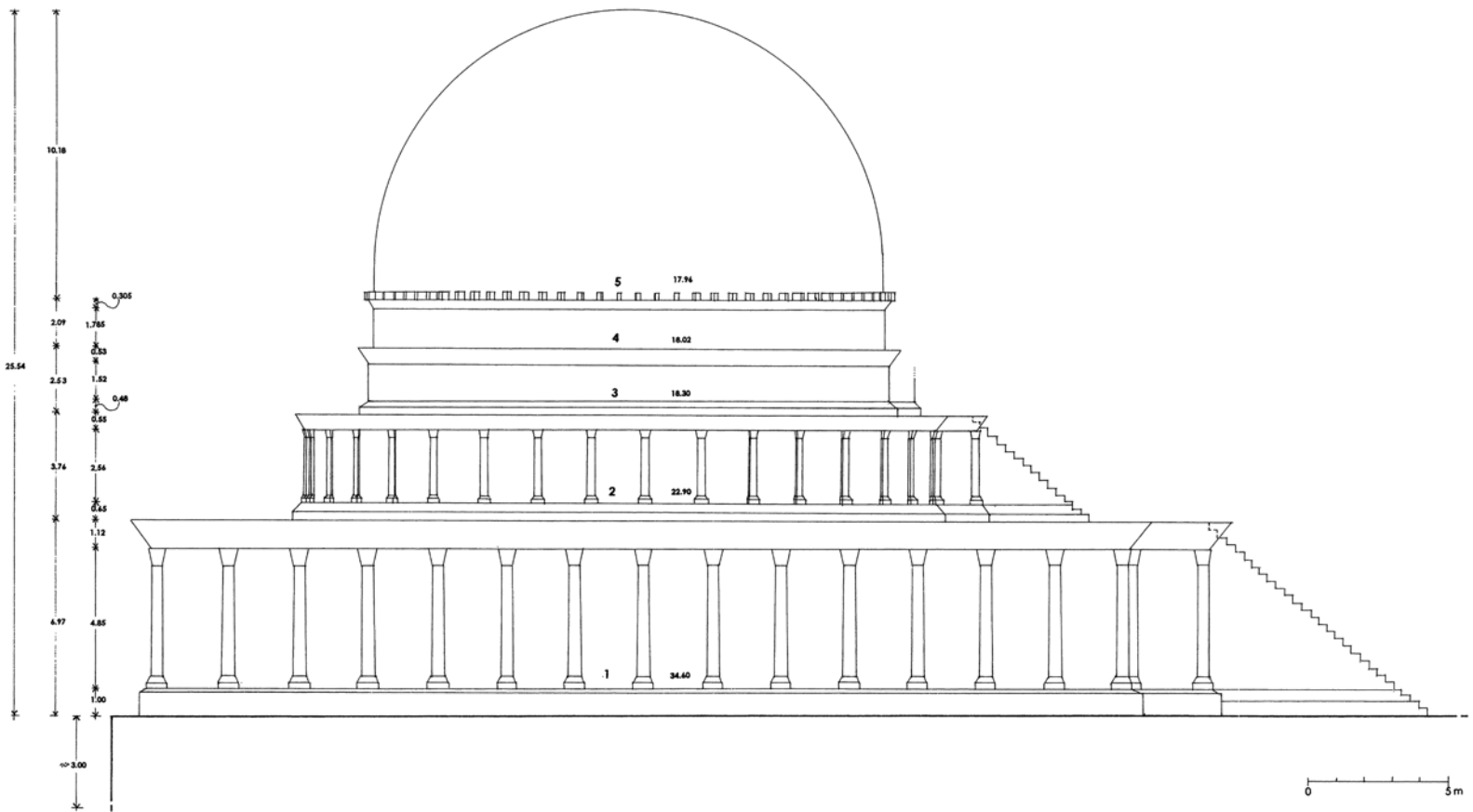

Fig. 198. Stupa of Amluk Dara. Sketch elevation showing the measures. (Martore 2004).

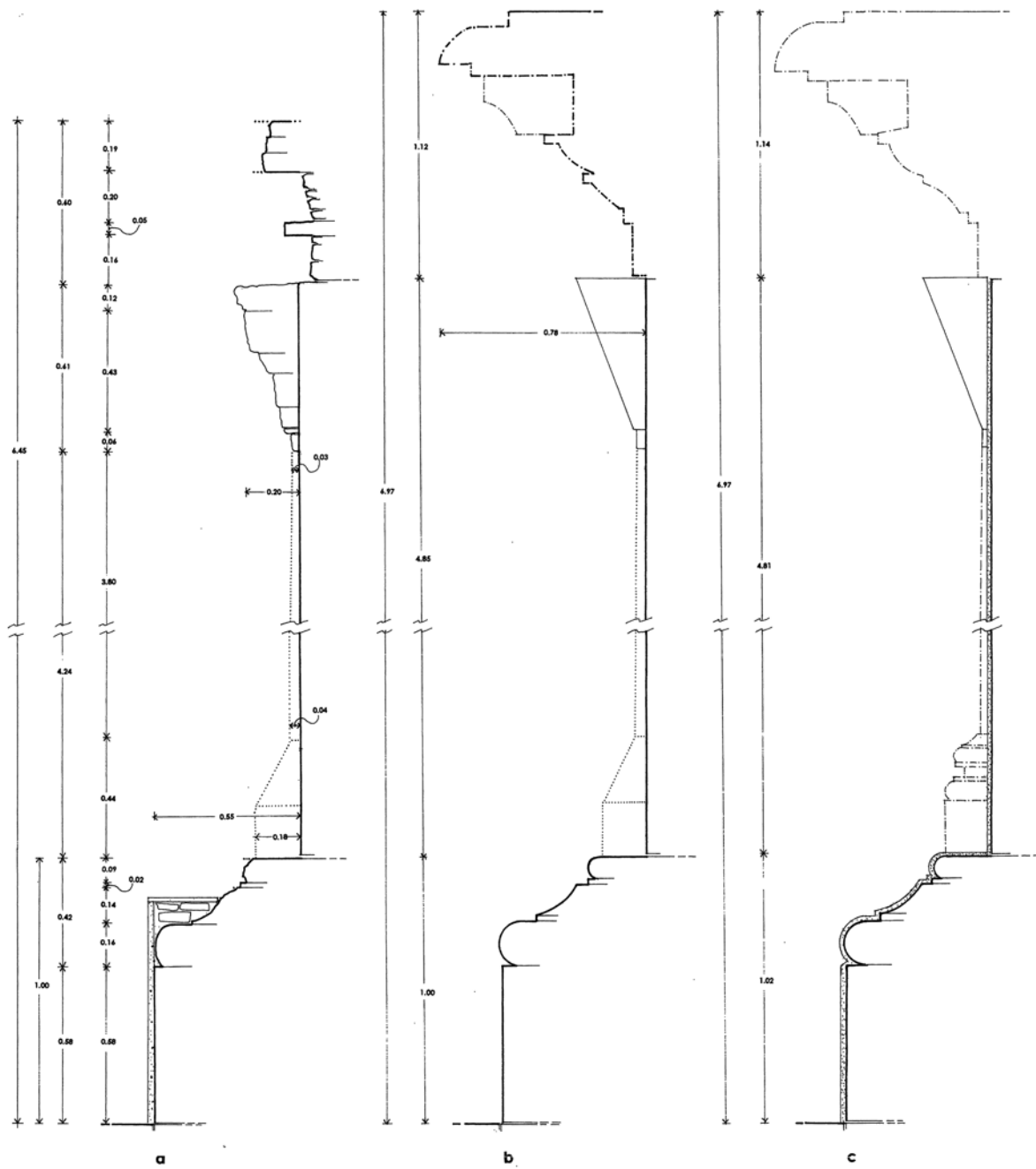

Fig. 199. Stupa of Amluk Dara. 1st storey. *a.* profile; W side, 4th pilaster from N; W capital, 5th pilaster from N. *b.* reconstructed profile, without plaster. *c.* reconstructed profile, with plaster. (Sabelli 1993; Martore 2004).

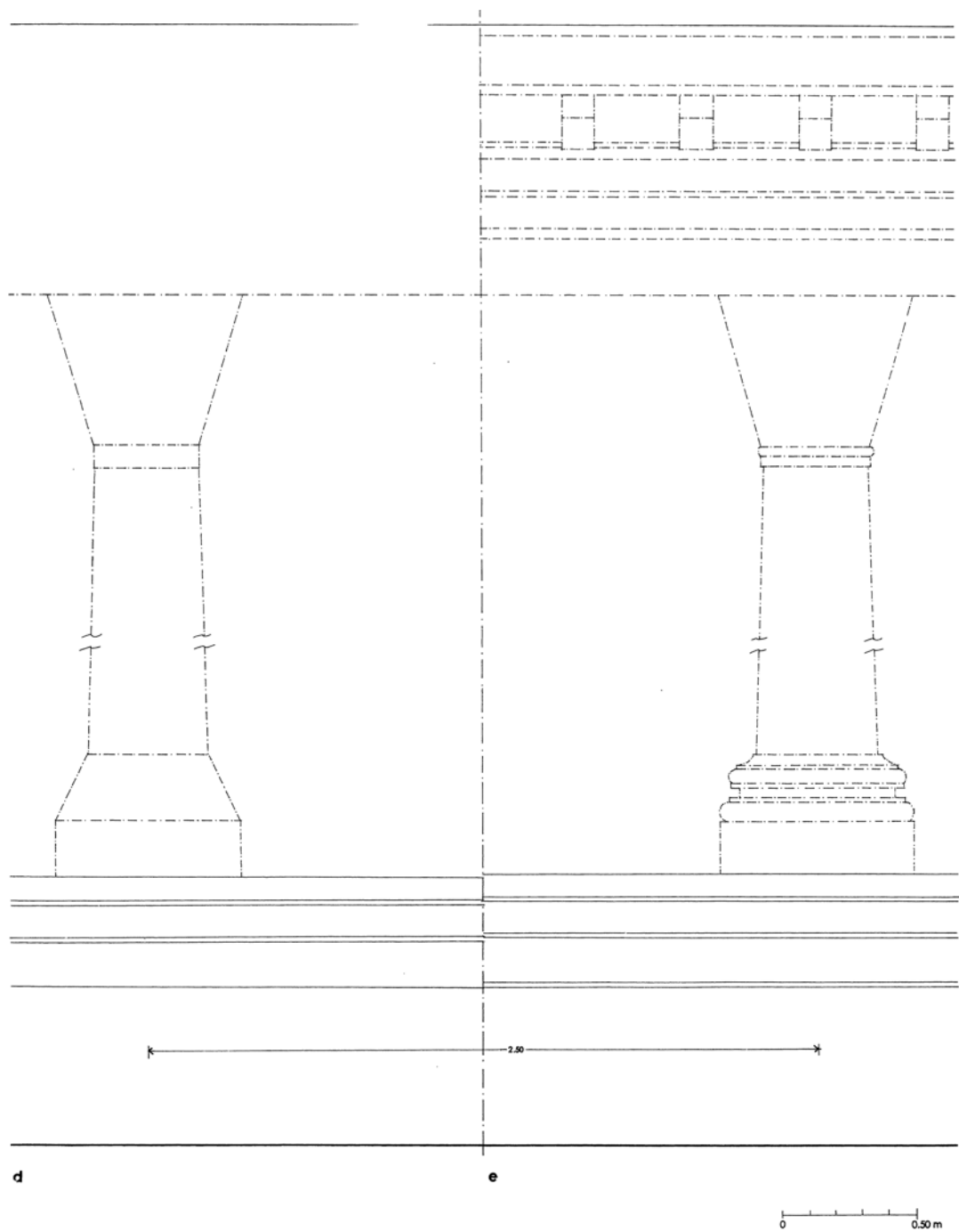

Fig. 200. Stupa of Amluk Dara. 1st storey. *d.* elevation showing the pilaster scheme. *e.* elevation showing reconstructed pilaster and cornice. (Martore 2004).

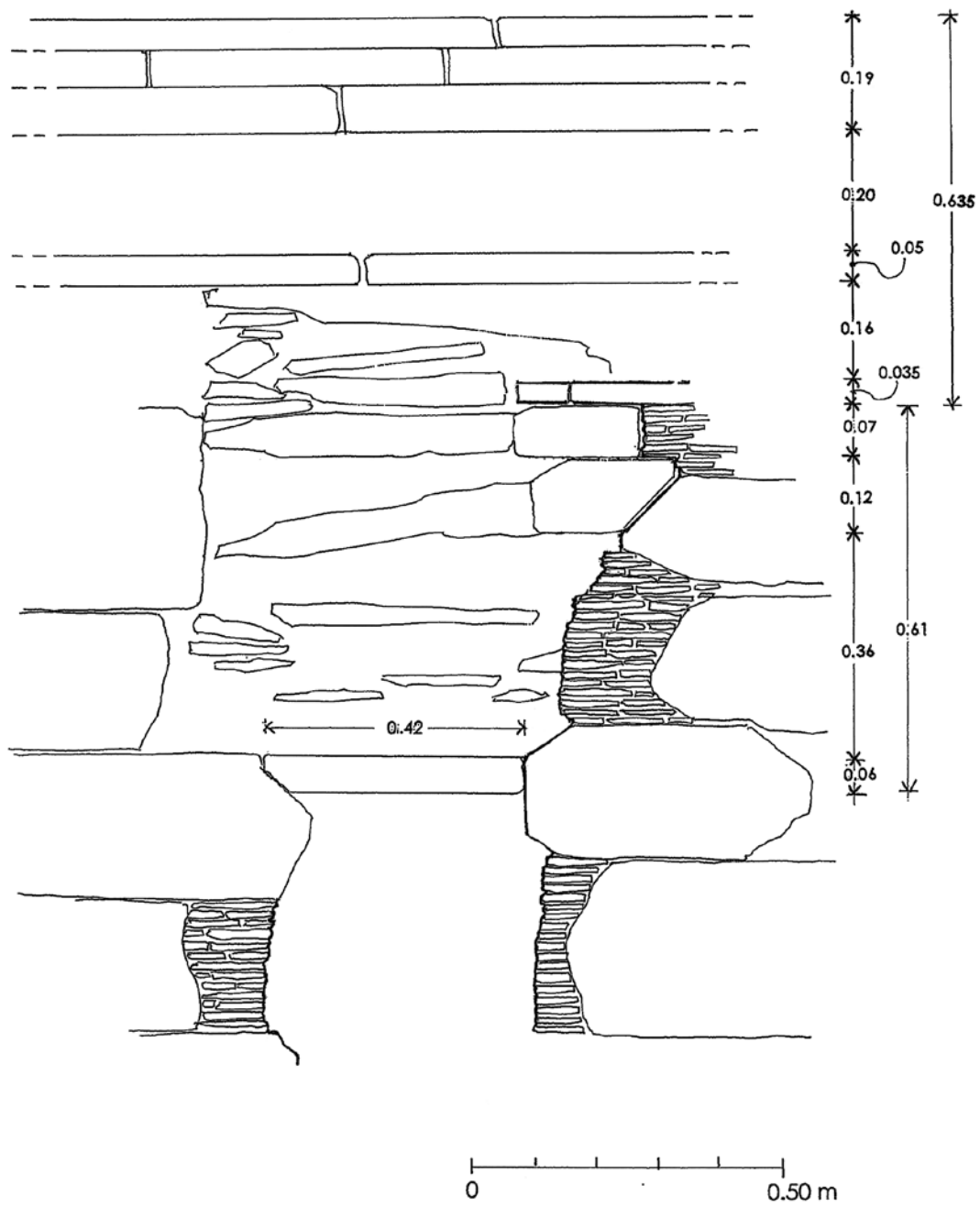

Fig. 201. Stupa of Amluk Dara. 1st storey. W side, 5th pilaster from N, capital and cornice. (Sabelli 1993).

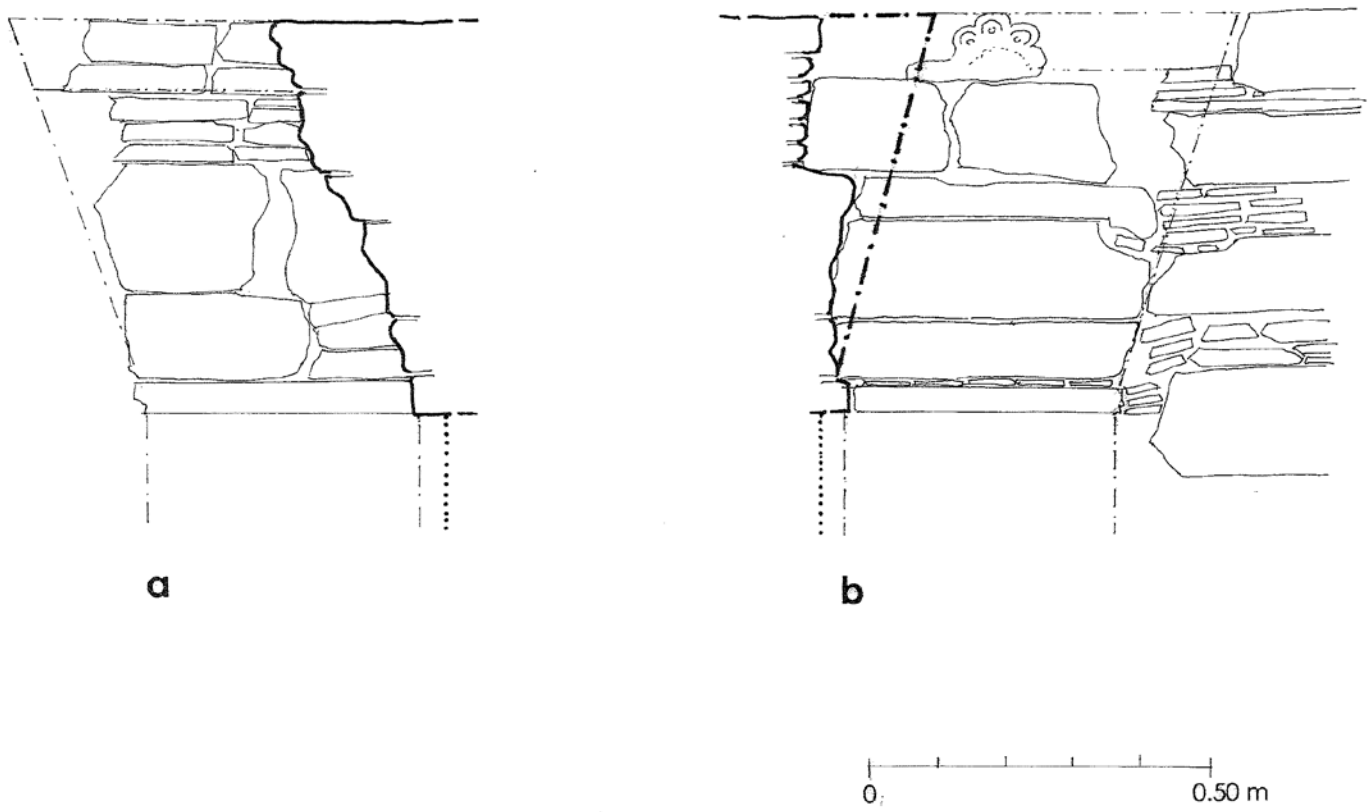

Fig. 202. Stupa of Amluk Dara. 1st storey. Stairway projection, W side. Drawing of inner corner capital, actual evidence. *a.* E side. *b.* S side. (Sabelli 1993; Martore 2004).

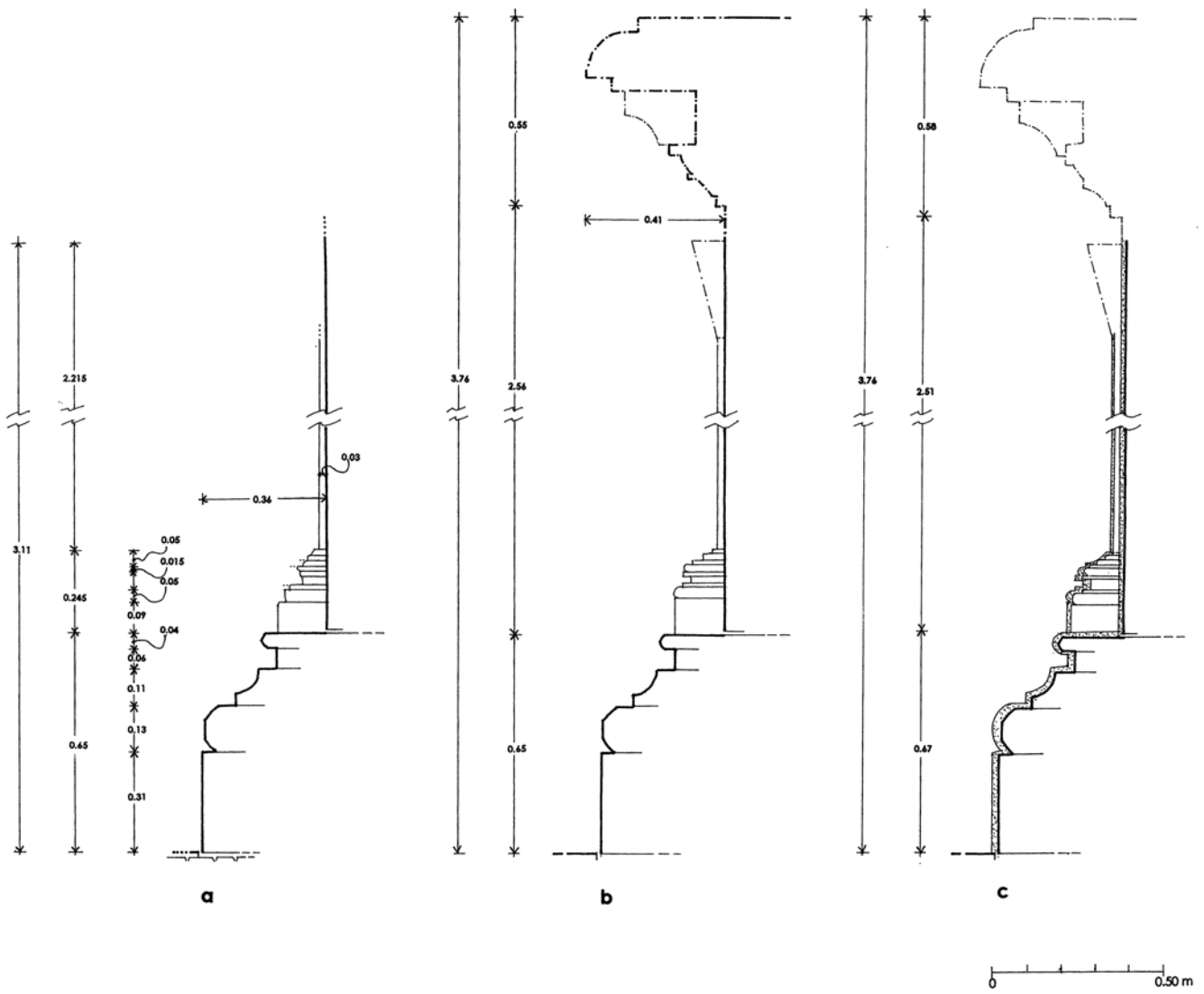

Fig. 203. Stupa of Amluk Dara. 2nd storey. *a.* profile. *b.* reconstructed profile, without plaster. *c.* reconstructed profile, with plaster. (Sabelli 1993; Martore 2004).

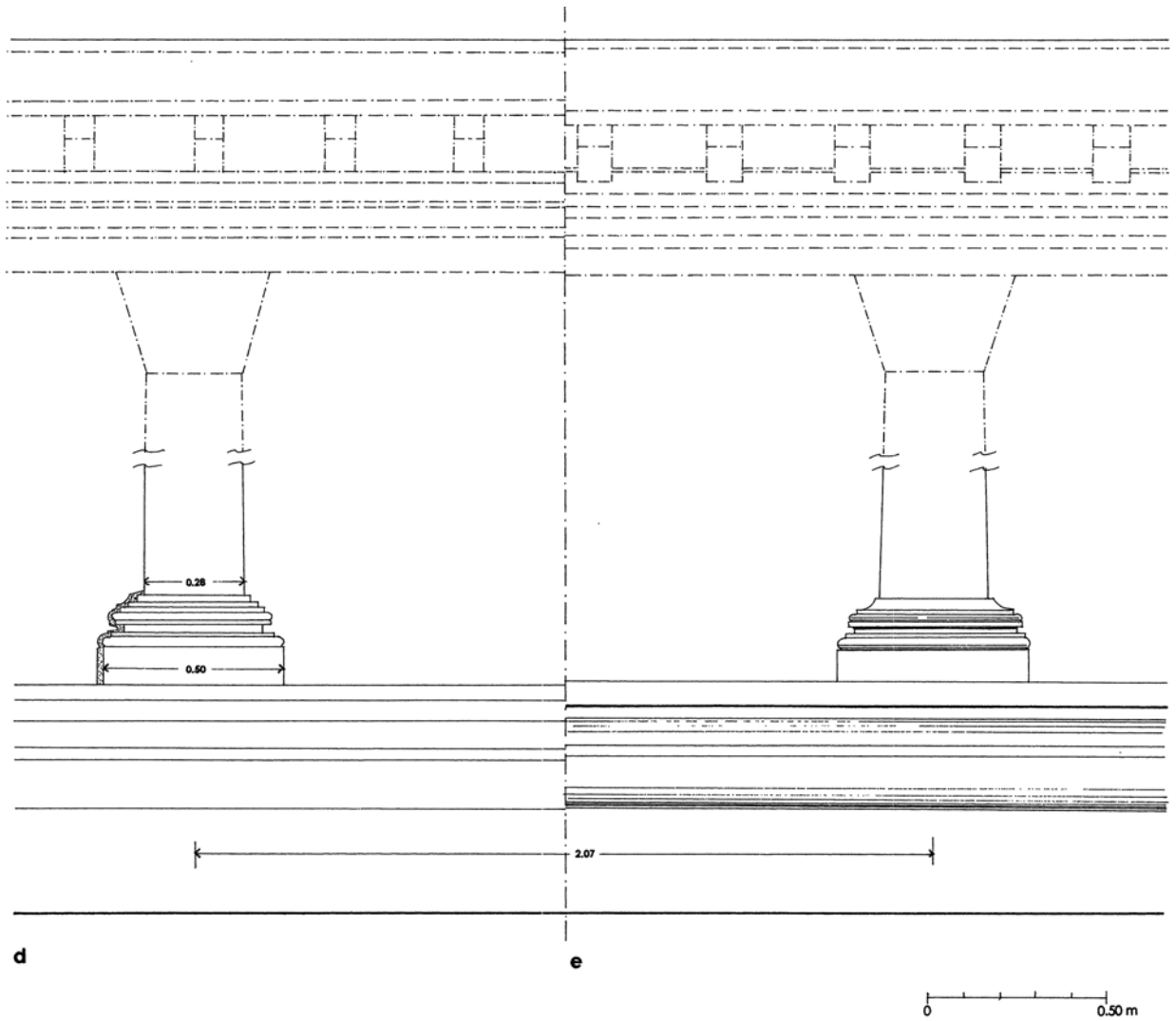

Fig. 204. Stupa of Amluk Dara. 2nd storey. *d.* elevation showing the real pilaster and the reconstructed cornice without plaster. *e.* elevation showing reconstructed pilaster and cornice with plaster. (Sabelli 1993; Martore 2004).

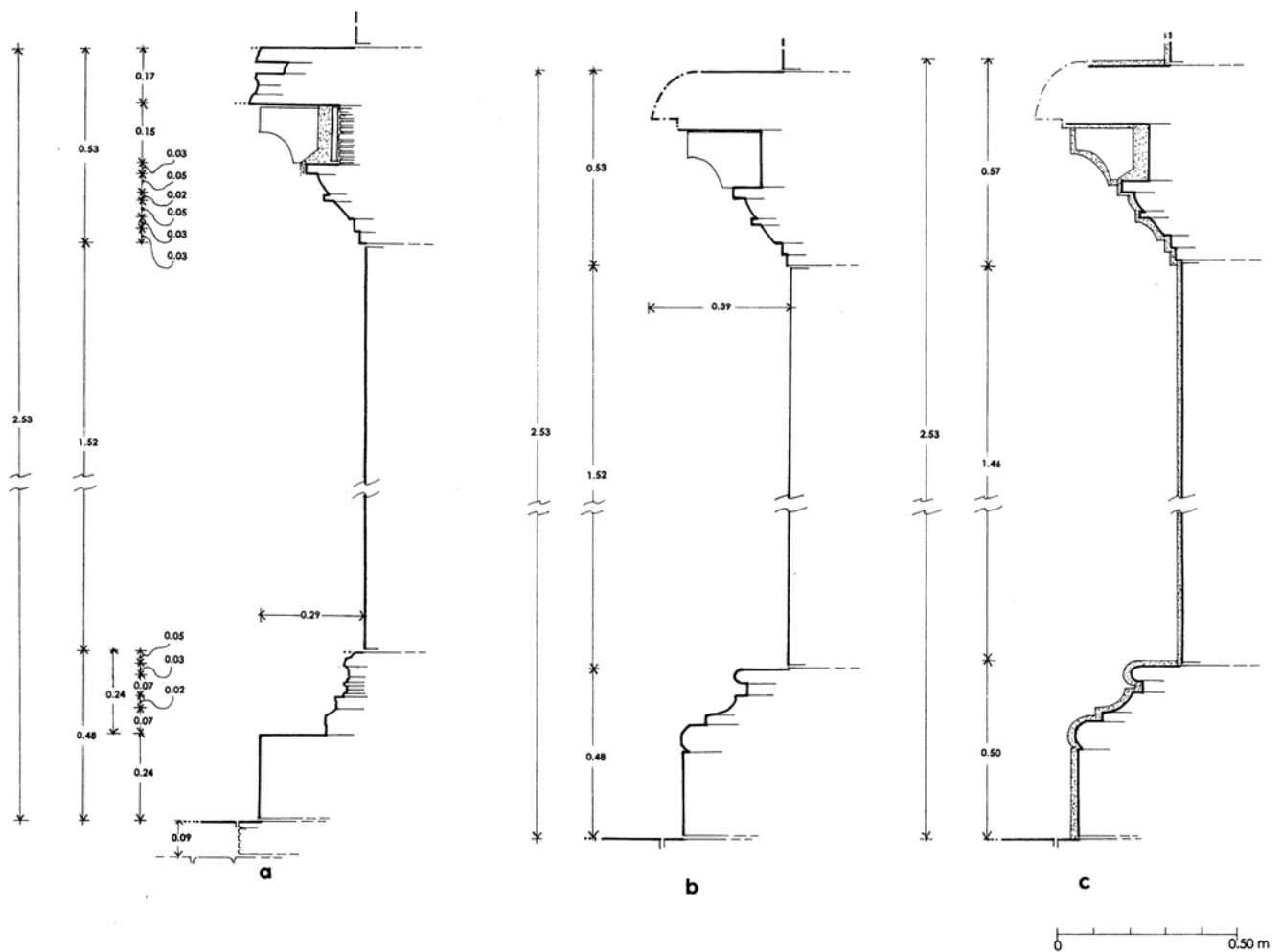

Fig. 205. Stupa of Amluk Dara. 3rd storey (drum). *a.* profile. *b.* reconstructed profile, without plaster. *c.* reconstructed profile, with plaster. (Sabelli 1993; Martore 2004).

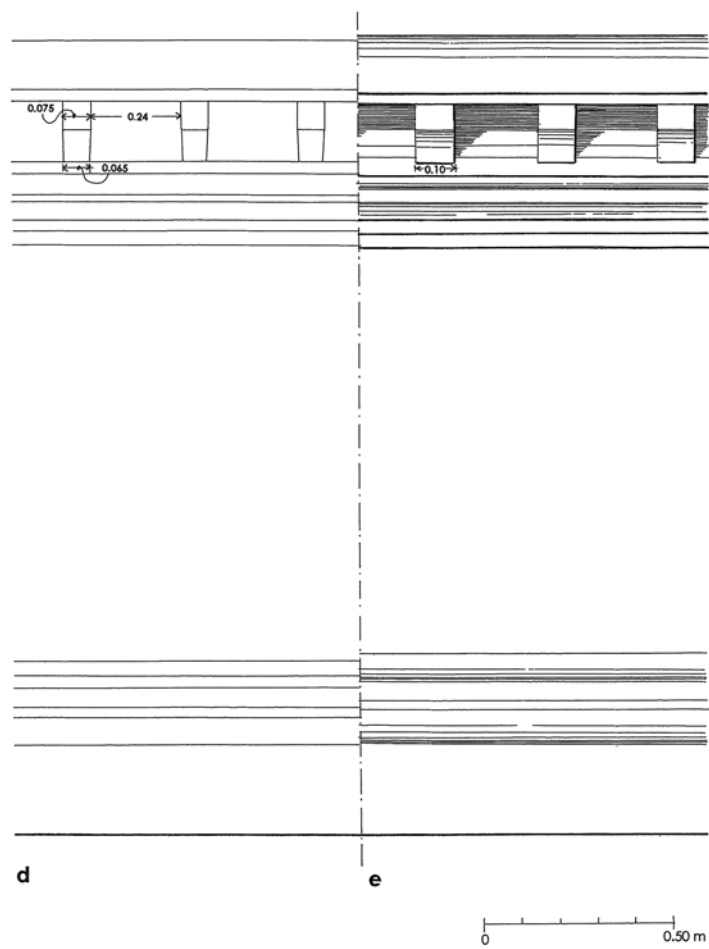

Fig. 206. Stupa of Amluk Dara. 3rd storey (drum). *d.* reconstructed elevation, without plaster. *e.* reconstructed elevation, with plaster. (Sabelli 1993; Martore 2004).

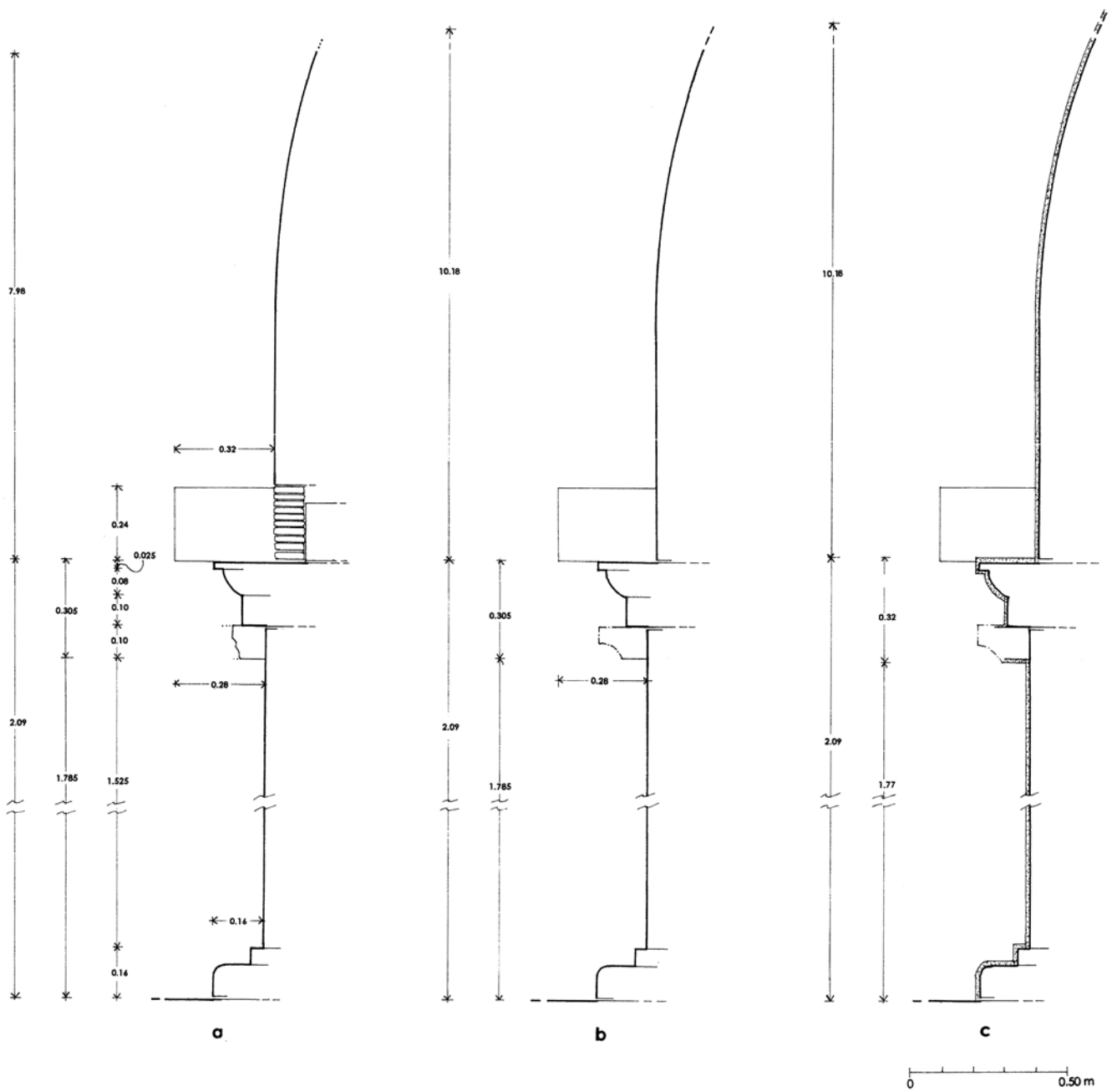

Fig. 207. Stupa of Amluk Dara. 4th and 5th storey, composite dome. *a.* profile showing 4th storey, transition storey, and 5th storey, raised dome. *b.* 4th storey, transition storey, and 5th storey, raised dome; reconstructed profile, without plaster. *c.* 4th storey, transition storey, and 5th storey, raised dome; reconstructed profile, with plaster. (Sabelli 1993; Martore 2004).

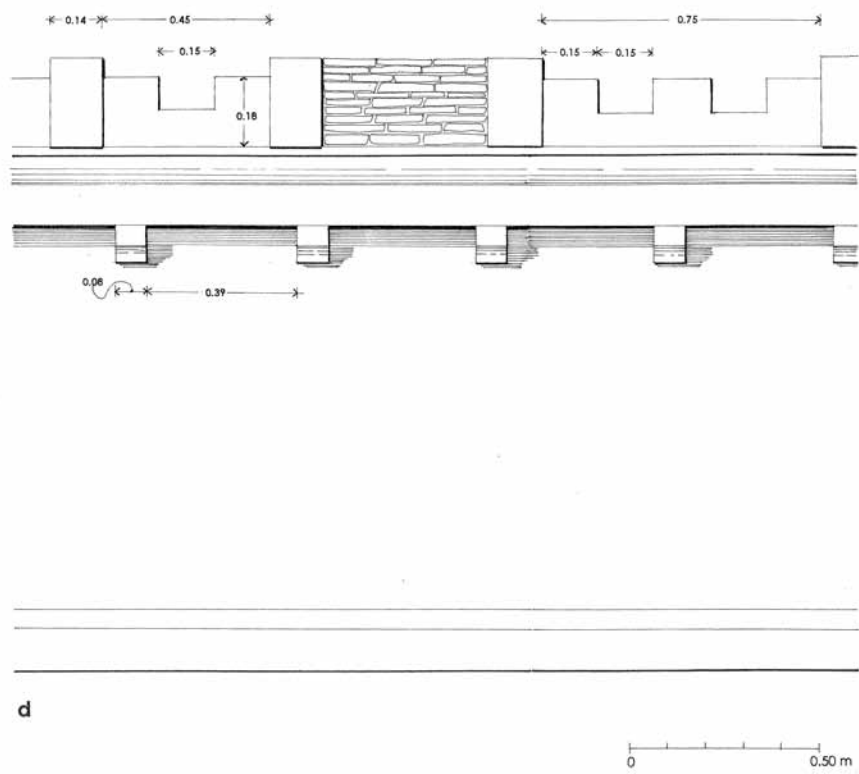

Fig. 208. Stupa of Amluk Dara. *d*. 4th storey, transition storey, and 5th storey, raised dome; elevation showing the measures. (Sabelli 1993; Martore 2004).

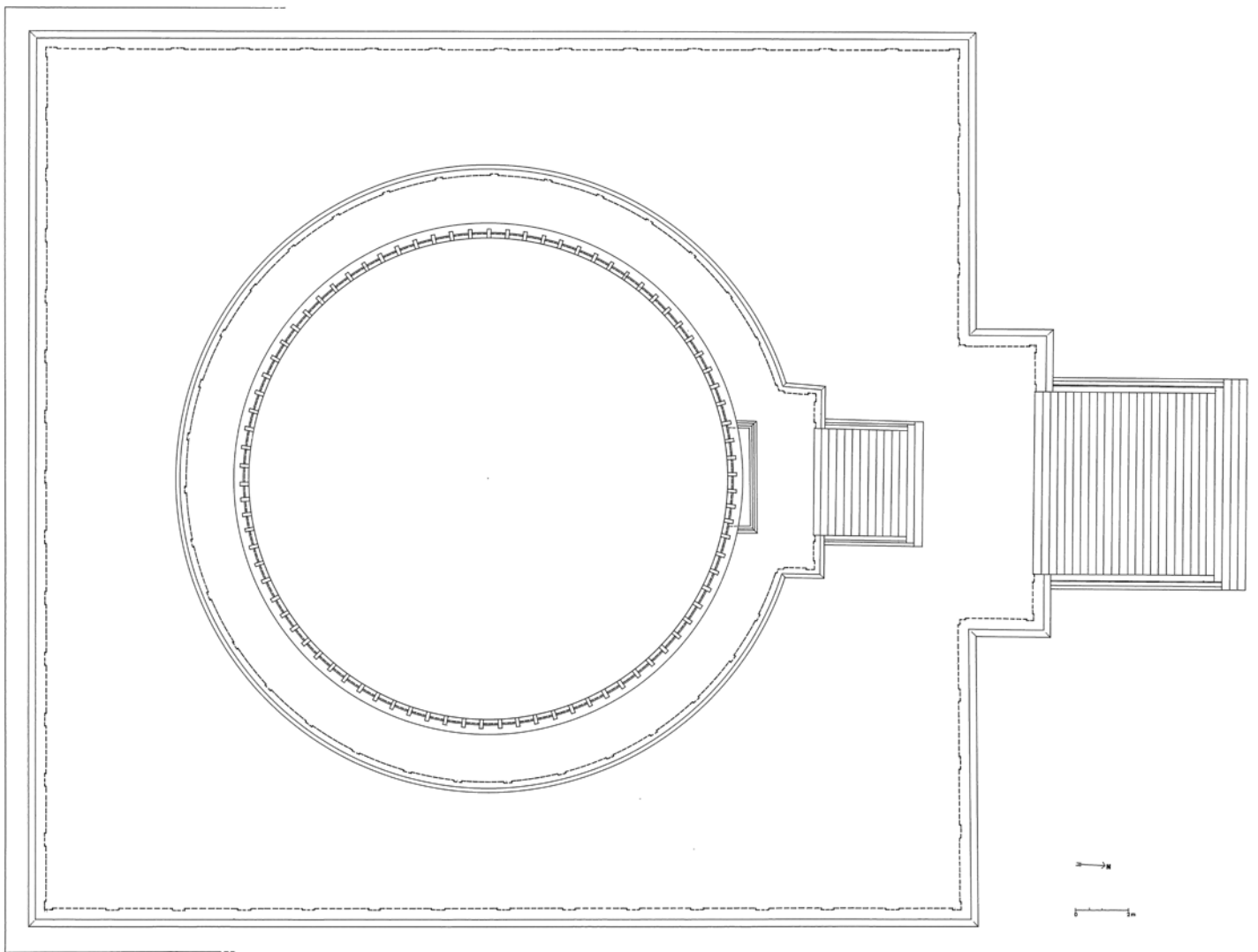

Fig. 209. Stupa of Amluk Dara. Reconstructed plan. (Sabelli 1993; Martore 2004).

A. Stupas

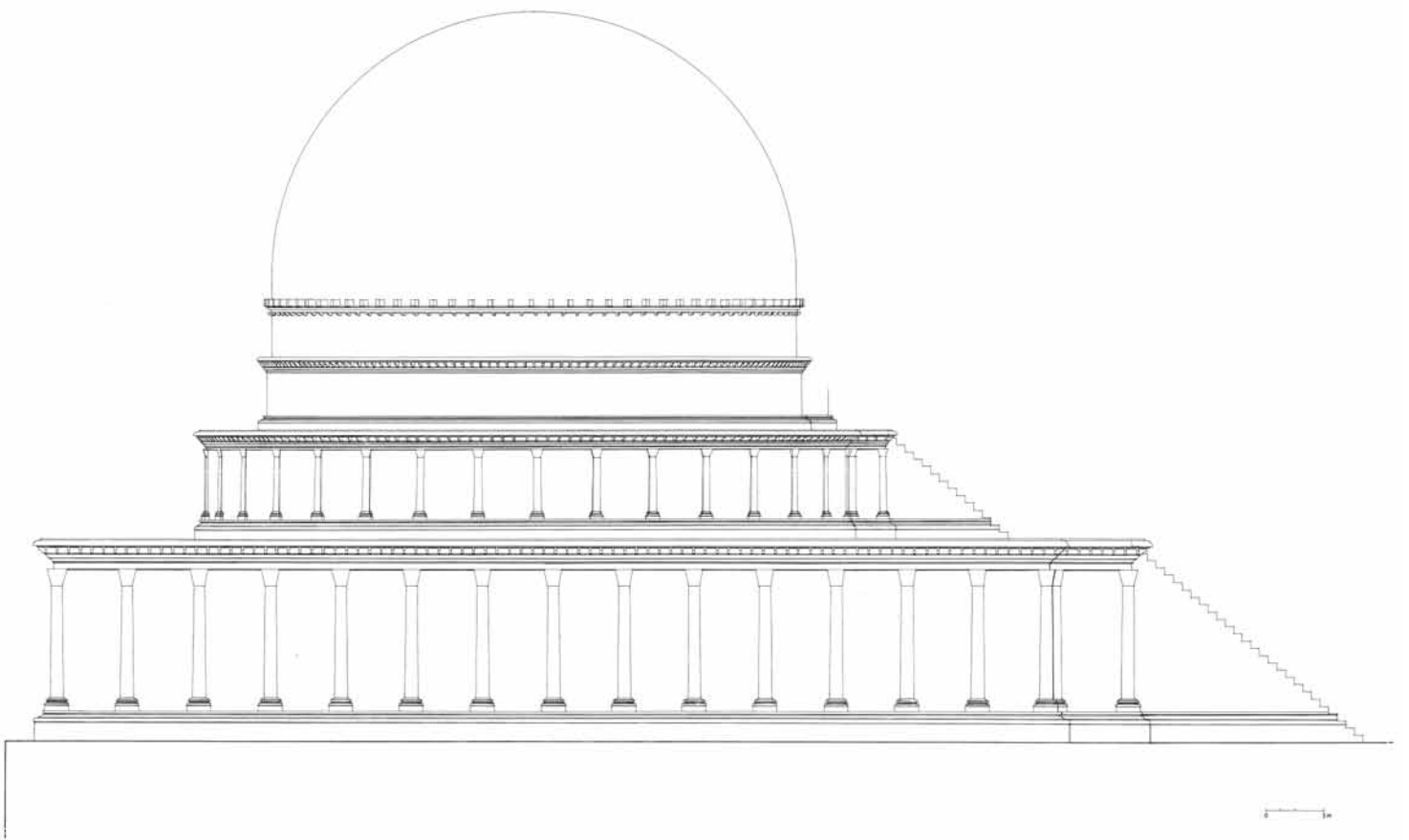

Fig. 210. Stupa of Amluk Dara. Reconstructed elevation. (Sabelli 1993; Martore 2004).

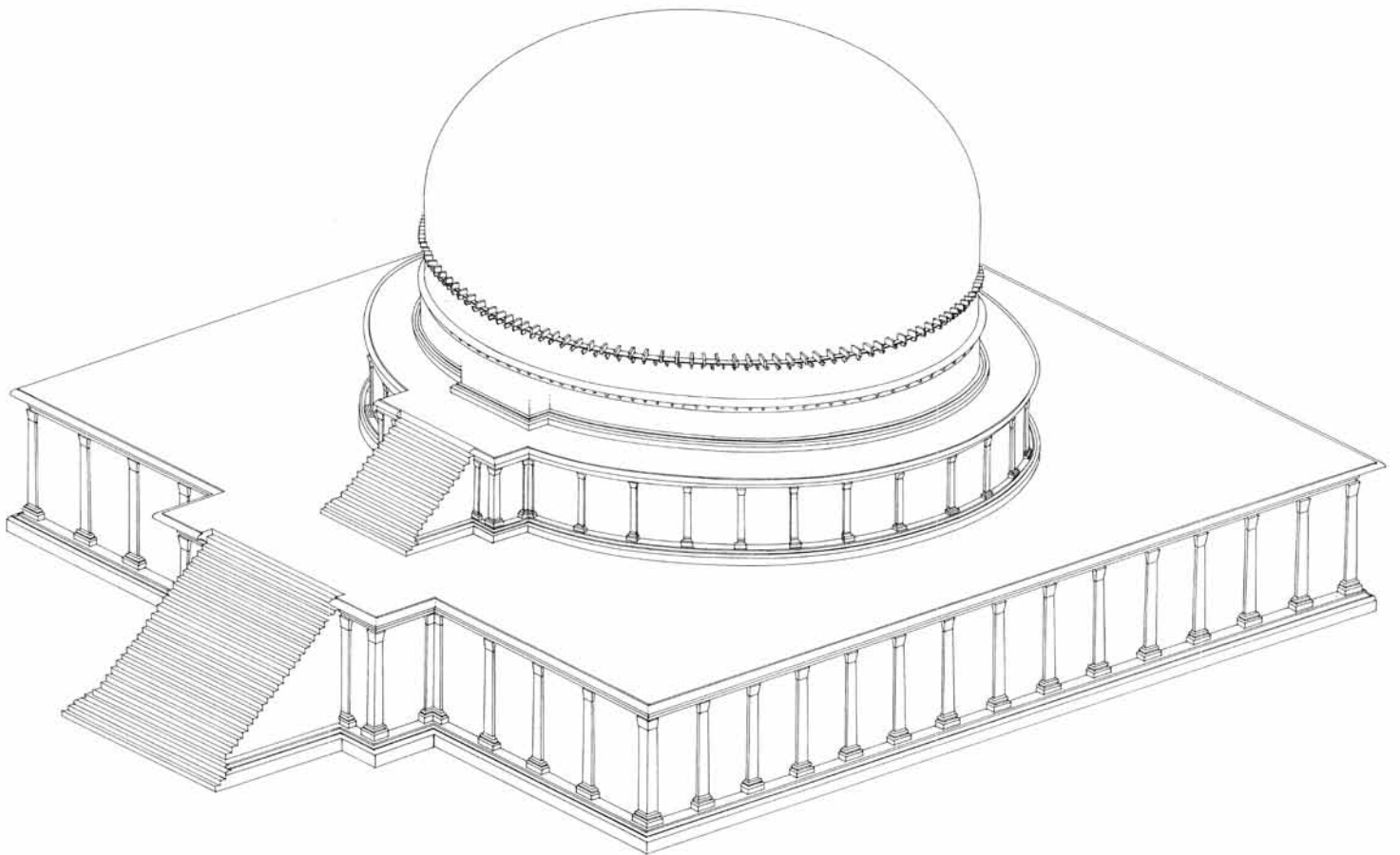

Fig. 211. Stupa of Amluk Dara. Axonometric view. (Martore 2004).

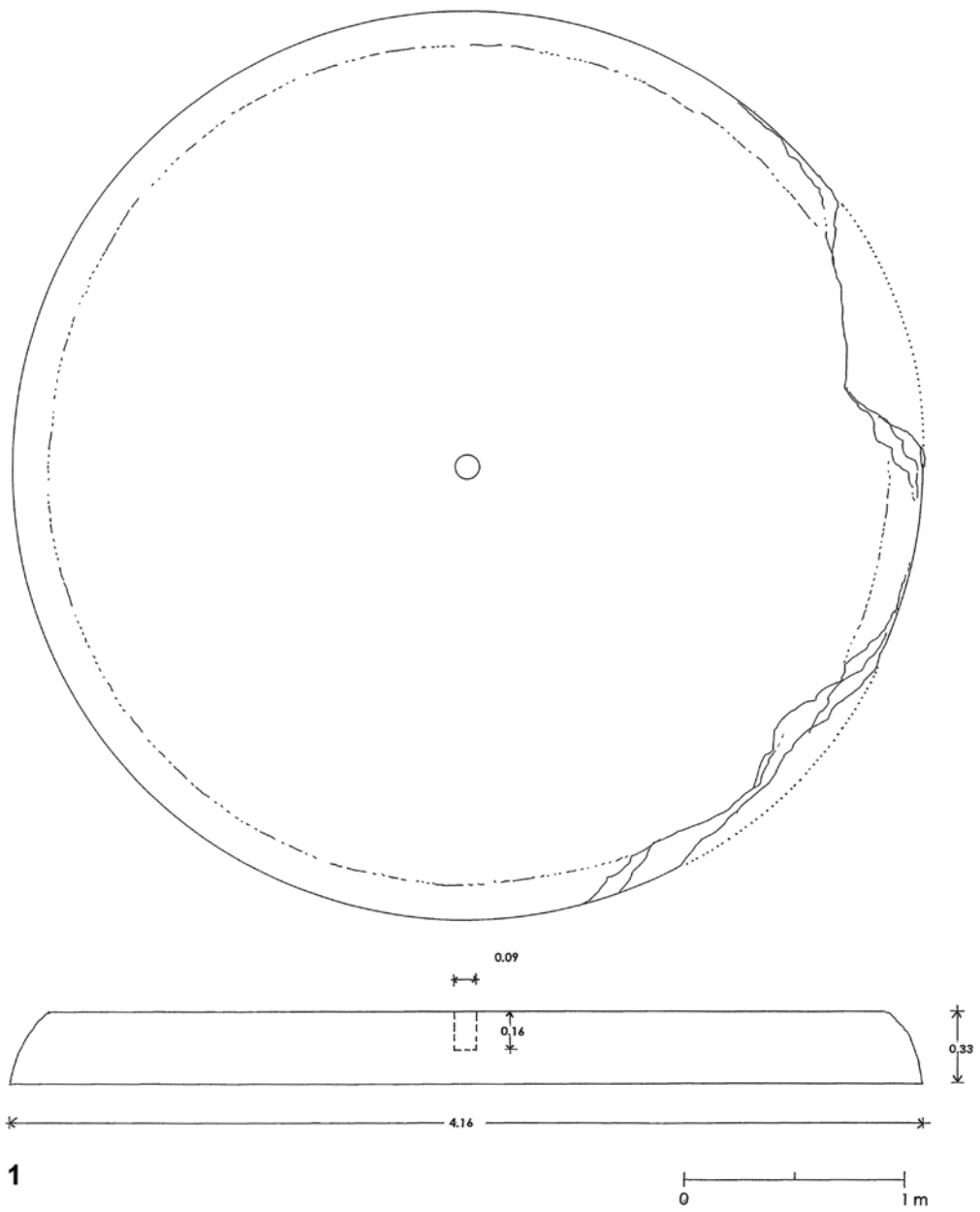

Fig. 212. Stupa of Amluk Dara. Chattravali disk no. 1. (Martore 2004).

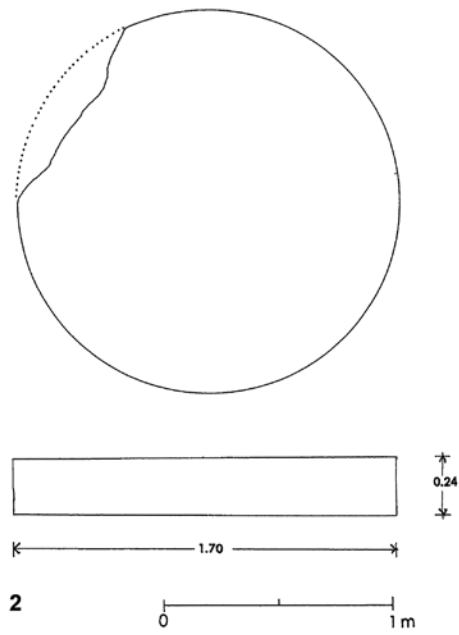

Fig. 213. Stupa of Amluk Dara. Chattravali disk no. 2. (Sabelli 1993; Martore 2004).

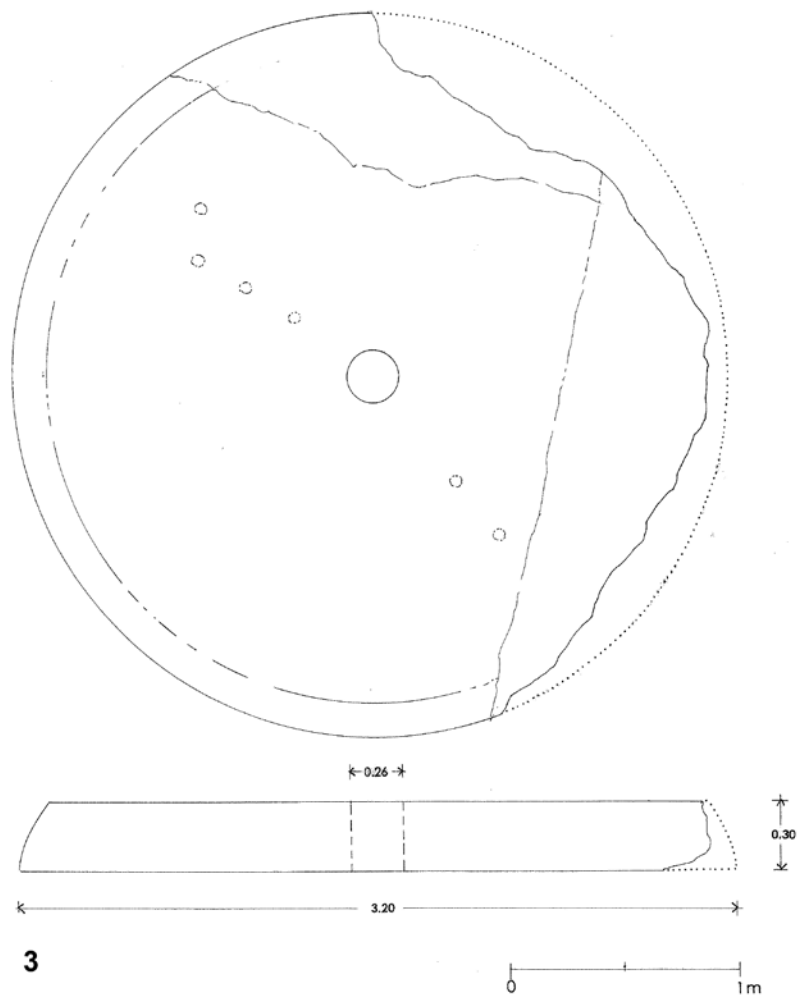

Fig. 214. Stupa of Amluk Dara. Chattravali disk no. 3. (Sabelli 1993; Martore 2004).

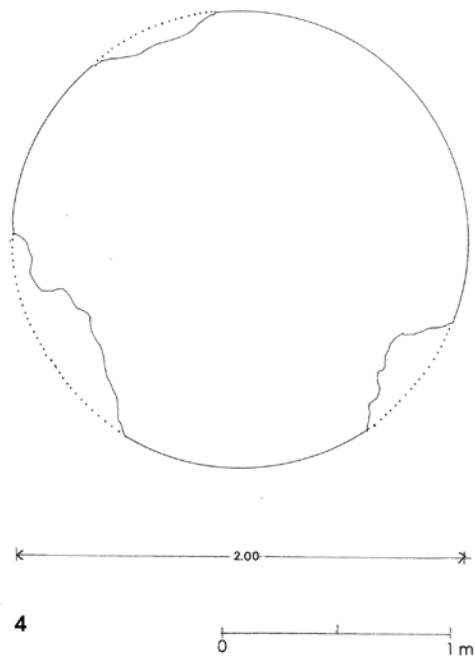

Fig. 215. Stupa of Amluk Dara. Chattravali disk no. 4. (Martore 2004).

A. Stupas

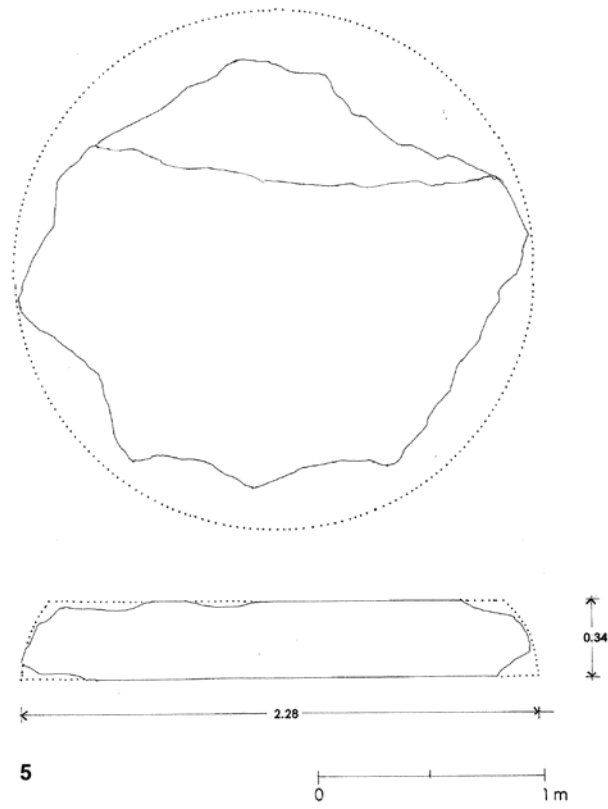

Fig. 216. Stupa of Amluk Dara. Chattravali disk no. 5. (Sabelli 1993; Martore 2004).

A10. The stupas of Abbasahebchina (Najigram)

(Figs. 217-323)

The Site

Zone of Barikot.

Position: Lat. 34° 37' N; Long. 72° 13' E; SPM 43 B/2.

Coming from Barikot, after passing the village of Najigram and following the bed of the stream of the same name, leaving at short distance away on the right the Sperki Gumbat complex (Tucci 1958: 317) ⁽¹⁾ (the stupa is large, conserved as far as the dome still with part of the outer facing; no survey performed; photo by Nascari), after skirting a low mountain spur, one follows on the right the Mandara nullah, which descends from Mt Sur-ghar. As it continues, the valley narrows within the steep mountain slopes, which are partly covered by pine tree (unfortunately now sparse as many have been cut). This leads to the central zone of the great monumental Buddhist complex of Abbasahebchina (Tucci 1958: 317-18) ⁽²⁾. A little further on there is a stream; on the mountain slopes, particularly on the

⁽¹⁾ 'To finish the description of the Najigram valley, mention should be made of an isolated stūpa on the left bank of the Najigram village: it is called Sperki Gumbat and it is surrounded by many ruins: all over the fields potsherds, chiefly of the Kuṣāṇa period, abound'. Other sites in the vicinity have been included in the Archaeological Map of the Swat Valley (Olivieri & Vidale 2006: 99-100).

⁽²⁾ 'Another very important archaeological site lies near a spring about three miles to the South-east of Najigram. The spring is in a lonely and most pleasant valley winding up to the Mandara Nullah, a torrent which flows into the Najigram stream. The spring possesses healing powers and the locality was certainly thickly populated: on the steep cliffs dominating the valley vast ruins of two storied building are well preserved: I am glad to publish here the plan drawn with his usual ability by Prof. V. Caroli of our Mission (figs. 31-32-33-34), representing stūpa A, stūpa C, a domed chapel, the major building, with stairway.

'On the slopes, small dwellings of hermits and monks testify to the intense spiritual life which once drew inspiration from the beauty and mystic silence of this place. The peculiar feature of this settlement is to be found in the domed chapels near the stūpa, evidently containing some images. The locality is called by its new name Abba Saheb China. The site of Abba Saheb China is full not only of Kuṣāṇa pottery but also of debris of Gandhāra sculptures (one was found on the spot) unfortunately it has been unskillfully excavated to satisfy the greed of treasure seekers and dealers from the plain, and also of some Sahibs who for a few rupees induced the local people to undertake clandestine excavations. Now all this has been brought to the notice of the Wali Saheb (who also possesses a fine collection of Gandhāra pieces and other antiquities and has taken a

W side, there are numerous buildings, sparse, isolated, supported by substructure walls, several quite large (see C1) and of particular interest as regards typology, layout and architectural elements.

Following the Najigram river from Najigram other monuments are found in the Jerando-dag area (ibid.: 318) ⁽³⁾.

Bibliography and Documentation

Overlooked by Stein (1930: 17) ⁽⁴⁾, it was examined by Barger and Wright in 1938 (1941: 24-25, pl. XI.3 general summary map, pl. XII map of the Barikot area and adjacent valleys), where they carried out research ⁽⁵⁾.

great interest in preserving the archaeological treasures of his country assisted in this task by his son, Prince Aurangzeb, and by the Chief Secretary, Ataullah Khan’.

⁽³⁾ ‘Following this stream downwards, and reaching again the Najigram river, if one turns to the right along the upper course of the same river one sees, in the middle of a graveyard, another imposing stūpa supported by a huge basement. The locality is called Jerando dag’.

⁽⁴⁾ ‘Returning towards Najigrām I visited two much decayed mounds found in the main valley about half a mile above the village and obviously marking completely destroyed Stūpas. Then following the lively stream the small Stūpa ruin, known as *Jrandu-gumbat* from a water-mill close by, was reached about 1½ miles further up. It too had suffered much from digging and quarrying. But the presence of two circular bases above a square one could still be made out and the diameter of the partly surviving drum determined as measuring about 18 feet. The near plaster moulding of two cornices decorating the drum was still preserved in place’.

⁽⁵⁾ ‘*Excavations at Abarchinar* [sic.] — A mile further south up the Najigram valley is the mouth of another wooded ravine, running parallel to that of Tokargumbat. A quarter of a mile up the path beside the stony bed of the stream which emerges from this ravine, a large group of monastery ruins comes into view, known as Abarchinar, (plan, plate XI, 3). The only building still standing on the right bank of the stream is a stūpa (A) of imposing size, and almost intact but for the usual cleft in the dome made by treasure-seekers. The dense undergrowth which enveloped the lower parts of this and all other buildings on the site made accurate measurement difficult. The massive rectangular platform or base of the stūpa, rising to a height of 30’ above the stream-bed, measured 40’ x 55’. Above this was the usual round base, carrying a dome divided into tiers by projecting cornices. Along the eastern side of the square base runs a low chamber or vaulted corridor.

‘On the opposite side of the stream the main group of buildings rise in tiers up the sharply sloping hill. The eastern end of the lowest series of terraces was evidently occupied by the living quarters of the monastery. An open court, (P) about 32 yards square, with a level grass-grown floor, is partly surrounded by the remains of stone-built rooms of various shapes and sizes, (S. T. V). On the eastern side of the court, these are backed against a high outer wall which is still intact to a height of about 40’ above the level of the ground outside. On the inside, the floors of the rooms vary in level, but are nowhere more than 15’ below the present summit of the outer wall. The latter, which was originally several feet higher, is pierced at varying heights with rectangular windows, splayed inwards. 10’ above the present floor level of room (S) a row of triangular niches, each formed by three long slates placed end to end, has been let into the wall. On the south side the containing wall rises 50’ above the bed of the stream. It is the outer edge of a platform honeycombed with small cells and vaulted chambers at various levels, the roofs of the lower chambers being for the most part a foot or two above the present level of the central courtyard.

‘West of the large courtyard and its surrounding chambers, the devotional buildings of the monastery are crowded onto a series of narrow ledges or artificial platforms between the bed of the stream and the hill which rises steeply behind them. The whole site is thickly overgrown with thorny scrub. Immediately west of the court (P) is stūpa (L) with a completely decayed dome carried on a round base 3’ high and 90’ in circumference. Immediately to the north of it are the remains (M) of a row of domed cells measuring about 12’ x 13’. West of the stūpa and on the same terrace is a rectangular open court (O), 54’ long, bounded on the north by the high wall of the terrace above and on the south by the remains of further cells and vaulted rooms (I). On the terrace above the west end of this court rises a large domed cell (F), measuring 10’9” x 13’9”. Part of the dome has fallen in; its highest point must originally have been 25’ above the level of the floor. At a

A. Stupas

Faccenna 1957: reconnaissance and examination of the monuments, together with Caroli who did the surveys (stupa A, C, vihara F, A1.1, Dwelling unit B1).

Tucci 1958: 317-18, figs. 29-30, 31-34 (survey by V. Caroli). Fig. 31 taken from Franz 1977: fig. 14.

Taddei and Scerrato 1959: photographic campaign, above all in the area upstream from the central complex.

Gui and Cimmino 1965: survey of the stupas A, B, C and of the vihara F (A1.1).

Mariani 1968: photographic campaign.

Franz 1980: 39-40, fig. 3.

De Marco 1982: photographic campaign.

Nascari 1992-93: photographic campaign.

Khan M. Ashraf 1993: 65, pl. XVI, figs. 49-51.

Kuwayama 1993: short photographic campaign.

Sabelli 1993: survey of the stupas A, B, C, of the vihara F, partial planimetry of the area.

Martore 2003: graphic ordering.

Behrendt 2004: 203-204, figs. 110-111.

Olivieri and Vidale 2004: reconnaissance for the Archaeological Map of the Swat Valley (photo Vidale 2000, Olivieri 2004). See Olivieri & Vidale 2006: 100, fig. 49; Spagnesi 2006: 162, figs. 10-11.

Spagnesi 2005.

higher level still are the stūpa (C) and the remains of a gigantic niche (D), 27' square, with walls still standing in places to a height of 30'. Before the open front of this niche are a series of ledges, each about 6' wide, descending to the level of the terrace wall. To the west of this is a small square cell (E) and next to that the stūpa (B). The stūpas (B) and (C) are almost identical in dimensions and construction, and a description of B will suffice for both. The square base or platform was traceable on the south or valley side, where it measured 21'. On the other three sides it had broken down and merged into the stony debris and scrub of the hillside. Above this the round base, 92' in circumference and originally 4'6' high, is practically complete. The drum it carries has been deeply quarried on the west side, but enough remains to show that its summit must have been reached some 15' above the top of the round base. Its surface is divided into tiers by two cornices of flat stones. The lowest tier and the round base are divided at intervals of 6' by pilasters formed of thin slates embedded in the masonry. Most of these have fallen out, leaving only the matrices or empty niches in the stonework.

'On the jungly hillside above the main group of buildings are the scattered remains of further buildings, mostly small vaulted chambers.

'Experimental trenches were sunk in the neighbourhood of all four stūpas. At stūpas (A) and (C), these produced only a few fragments of much battered reliefs. Clearance of the round base of stūpa (L), at the north end of the large courtyard, was more productive. The dome of this stūpa, as already mentioned, had completely crumbled. The fact that its sculptural remains were far more numerous than those of the other stūpas at Abarchinar, all of them relatively intact, is an interesting instance of the inverse proportion frequently observed between the extent of the preservation of the building itself, and of its sculptural decoration'.

The Central Complex

On the two sides of the rocky stream dividing it in two the central complex is situated on terraces with substruction walls and transition stairway. Retaining the indication of the monuments using capital letters suggested by Barger and Wright, to whose description and map the reader is referred, on the right bank of the stream we find stupa A, which stands out in a dominant position; on the opposite bank, in front, to the N, lies the monastery with courtyard and cells; to the W, on a terrace, lies the vihara alignment, including the great vihara D, with stupa C; at the end, to the S, the stupa B and the vihara F, which seem to mark its closure, opposite the monastery.

A few details should be noted. The substruction wall contains a niche with pointed (ogival) arch low down, on the front, about half way along its length; the wall has a curved projecting cornice; at the right end there is a stairway, which winds up to the terrace level and forms a rounded angle with its supporting wall; stupa B and the vihara F have steps facing the terrace.

The vihara D, the walls of which rise to a considerable height (it dangerously slopes inwards on the N side), with an entrance with corner antas and pilasters and two small windows (?) superimposed on the rear wall, it springs from a podium that extends to the E forming a projection; it is accessed by means of two stairways facing each other to the N and S; a niche is situated in the lower middle part of the substruction wall of the projection (practically repeating the same motive of the terrace substruction wall). The cell measures 7.45 in depth and 7.85 in width, with a 4.80 wide door and an anta projection of 1.47.

The buildings (indicated as M by Barger and Wright), which in stupa C have N alignment, again on the same terrace, are four in number, quadrangular in plan, with the front. E wall missing. Vihara M1, the first on the left, retains a section of cornice on the N wall consisting of a fillet and ovolo and brackets between two fillets, from which projects the beginning of the dome. In the S wall of vihara M2 a section of cornice has been conserved which is identical to that of vihara M1 but situated at a slightly lower level; inside, the springer of the dome on slabs having a greater projection in the corners, which is reduced in the straight section of the wall. Vihara M3 conserves a substantial section of the dome which repeats the motifs already found on the outside (ovolo and bracket, each element between two fillets) and on the inside (projecting slab). A section of cornice is found on the S wall of vihara M4. Between the stupa C and the vihara M1 lies the stupa stairway.

In the monastery room S has tall windows side by side in the N wall, the splayed sides and sloping threshold of which have been conserved; at a lower level on the three walls, there is a series of small triangular niches made out of three schist slabs (h. 0.20). One of the monastery rooms has a barrel vault that is perfectly well

A. Stupas

conserved and of excellent workmanship.

From the layout of the structures and the lay of the land it is possible to discern the probable access path(s) to the complex from the N, passing behind the monastery and the row of monuments on the terrace.

The two groups of monuments on the right and left of the stream were probably linked by a kind of bridge spanning the stream as they were at the same height.

We add here the note referring to the two monuments that, although visible in 1957, now no longer seem to exist or at least are no longer easily identifiable (Faccenna 1993), situated just before the central complex is reached.

Prior to this there was a stupa, quadrangular in plan, decorated with Gandharan-Corinthian pilasters (particularly visible was the inner corner pilaster between the body and the projection of the stupa, with a Gandharan-Corinthian capital), with a projection and stairway to the N; medium size; it retained part of the 2nd storey, circular in plan; it is also decorated with pilasters. Measures: 1st storey, quadrangular in plan, leng. 2.30, visible h. 1.80 (pilaster h. 1.30, cornice h. 0.50); the h. of the base that projects by 0.20 is not visible. Projection: leng. 0.70; stairway, conserved leng. 2.30. 2nd storey, circular in plan: max. h. 1.00 with base h. c. 0.35.

A short distance away to the S, almost set off against the other, stood a small vihara with a rectangular plan (see B1.2).

Lastly, outside the complex, on the W slopes of the mountain, lie other ruins, which probably include a monks' dwelling unit (see C1).

Stupa A

On the right bank of the stream stands stupa A, isolated in the middle of a terrace; behind it, to the W, rises the mountain slope. It consists of the 1st storey, quadrangular in plan, two progressively set back circular storeys, the second of which may be considered to be the drum, and the composite dome, provided with a transition storey. It has stairways facing W corresponding to the 1st and 2nd storey. Comparatively well conserved, to the W it has a large gap, which from the top, limited to the height of the 3rd storey in 1957, now descends as a central shaft into the 1st storey, entering the core horizontally. It is supported by retaining walls, visible to the S, N, and W, the side overlooking the stream, the bed of which lies at a much lower level, about 10.00 (30 ft.) below (Barger & Wright 1941: 24).

The retaining wall follows the line of the stairway projection, and descends much lower, certainly as far as the stream bed; visible, about c. 0.60 below the stupa grade level, is a string course, more conspicuous in the NW corner, with slabs projecting by 0.17. A wall, 1.50 wide, abuts the substruction on the N side, topped by a layer of slabs at the level of the stupa grade, perhaps corresponding to a floor. It was interrupted by a collapse on the W side, and returns with the core also on the S side; it probably also wound round the W side, incorporating the substruction wall. On the same N side another three masonry structures are visible towards the front, separated and parallel, at a lower level of the stupa, belonging to rooms adjoining it. We know nothing about the layout of the E side of the stupa and thus of the area, with reference to which Barger and Wright noted the presence of a low room or a vaulted corridor (1941: 24: 'Along the eastern side of the square base runs a low chamber or vaulted corridor'), unless they were referring to the structures on the N side.

The facing of the stupa is made of blocks arranged in rows that are rather regular in height; the blocks are made of limestone, framed by thinner slabs with the same and larger slabs between one row and the next.

The core is composed of large slabs and smaller pieces, bonded with earth and using careful workmanship; large stones bonded with those of the facing extend in rows over the entire surface of the storey, alternating with smaller sized stones and rubble, held together by clayey soil. A few rows of larger stones seem to act as foundation layers corresponding to the mouldings although there is no certain evidence of this.

1st Storey, Quadrangular in Plan

Storey measures: leng. N, S 16.50; E, W 16.30, h. 4.48.

It is provided with pilasters and stairway with a projection towards the W. It

has a scotia base; composed of plinth, upper and lower tapering torus comprising two slabs, scotia with vertical cut between two fillets, each comprising one slab, cavetto with five gradually set back smaller slabs; closed on top by one set back fillet and another projecting fillet, each comprising one slab. The latter supports the pilaster. The pilaster has a scotia base repeating the motif of the stupa base, with mouldings made using single large or small slabs; the slightly tapering shaft is composed of small blocks alternating with rows of small slabs; the capital is made of superimposed slabs varying in projection, height and profile, the last slab above making up the abacus with extremities projecting forwards and sideways and with a slightly projecting profile at the centre. The modillion is composed of a tall slab and by superimposed rows of thinner slabs, sometimes interspersed with thin slabs. The lower slab has an oblique lateral face and is separated by a series of small superimposed slabs hanging from the extremity of the upper slab. There are 26 pilasters including the corner ones on the N, S and E sides; they have an interaxis of 2.35.

The plaster coating is thick, conserved in many places, and is used to give the profile and shape to the various elements. The toruses of the stupa base and of the base of the pilaster take on a rounded profile; the scotia is hollow; the shaft has a long central groove with a possibly curved upper extremity, the lower one is concave; the capital is curved in the upper section where the projection of the slabs is greater; then comes the abacus with a projecting extremity and on the front of which, in the centre, a projecting part possibly corresponding to a leaf or rosette, and thus therefore probably corresponding to a Gandharan-Corinthian (or Tuscanic?) capital. The modillion displays a volute and recess on the lateral extremities, decorated with a carved modelled leaf, the remains and furrows of which are conserved; in the upper part of the first band, below, a row of ovolos with a double rim with central furrow, a row that continues along the wall among the modillions, set back with respect to the other. On top is the architrave with its two bands at different heights, enclosed above and below, and both separated by projecting fillets; the top of the upper band is decorated with dentils (and small arches? which are hard to make out owing to their bad state of conservation; in the sketches they have been shown as dentils). It is followed by the bracketed cornice; from bottom up: ovolo and projecting slabs for the fillet, the series of brackets, projecting slabs forming a reverse ovolo, coping slab; the bracket, supported by its own isolated small slab comprises a vertical slab; the bracket-spacer consists of small horizontally superimposed slabs, sometimes also with small blocks.

In the wall between the pilasters, slightly above the level of their base, there is a fillet formed by a row of projecting slabs (0.15), which runs along the entire space. Below this there are traces of plaster and pinkish colour. Gui and Cimmino's sketch (1965) shows traces of a series of arch-shaped curved lines (palmettes?).

Traces of red colour are visible on the capitals.

All that is left of the stairway, situated to the W, is the N side of the projection, badly tilted as the result of a collapse; the S side is missing. A small section of the facing is conserved with the base and cornice and inner corner pilaster; there must have been another external one on the front. The remains of the core seem to point to a stairway 2.15 wide, with 16 steps and an inclination of 41°.

The collapse of the NW corner of storey revealed an internal structure, about 0.50 from the outer wall, comprising two superimposed bodies, the upper one set back, with a facing which was not intended to be visible, characteristics of the 'internal' type. In the S section one of these bodies can be seen to continue, following the same alignment. The same alignment can apparently be observed inside the projection, parallel to the width. There is no doubt that the structure was built to provide an initial support against the thrust of the mass behind it in the weakest point of the structure, overlooking the stream.

2nd Storey, Circular in Plan

Set back by 1.50 to the W, 1.30 to the N, 2.00 to the S; 2.80 high, with a diam. of 12.45, decorated with 22 pilasters with an interaxis of 1.65. The profile of the 1st storey is repeated in the base and cornice of the storey, as well as in the pilasters. To be noted: the groove in the shaft has a concave lower extremity, probably repeated in the top part; the capital, with the same structure although reduced and simplified, with a straight intermediate section, juts out in the central part of the abacus, forming a Gandharan-Corinthian type; the architrave consists of a single slab, the plaster coating of which is divided into two bands; traces of plaster.

The stairway of the 2nd storey is aligned with that of the 1st storey; to the S there still remain the join of the projection and a short section of the base of stairway with the core; 1.60 wide, with 10 steps and an inclination of 47°.

Traces of the storey paving remain; it was possibly raised; it is visible at a slightly higher level than the grade plane of the latter's base.

3rd Storey, Circular in Plan (Drum)

Set back by 1.35, 1.80 high, diam. 9.70; decorated with 24 pilasters with an interaxis of 1.35. Unlike the preceding one, the base is of the torus type, with plinth, three-sided bevelled torus, cavetto formed by small slabs; closed by a set-back two-slab fillet and by another projecting slab. The pilaster has a torus type base, carinated, obtained from a slab and cavetto with three small slabs; shaft with traces of grooving marked by a short furrow by the concave extremities; capital with a structure similar to the preceding one, simplified; single-slab architrave;

bracketed cornice, with each bracket composed of two vertical slabs and above this a reverse ovolo made of corroded slabs and with a broken front; no coping slab.

The plaster, of which extensive traces have been conserved, outlines the profile of the structure. At the base of the storey and the pilaster the torus is rounded with a cavetto; the pilaster has vaguely defined grooving, probably imitating those below; the tapering capital continues the motif of those below; the modillion with the upper part decorated with a double edge and central groove; the architrave is divided into two zones, and repeats the motif of the ovolo in the upper part; the cornice consists of an ovolo between two fillets, a bracket between two fillets, a reverse ovolo.

Traces of red colour around and inside the row of ovolos.

4th and 5th Storeys (Composite Dome)

4th Storey, Circular in Plan, Transition Element

H. 1.09, diam. 9.70. Aligned with the 3rd storey wall, it is supported by a slightly projecting slab, with smooth wall, slightly recessing on top; it terminates with the projecting slab inserted into a recess and held in place by small slabs that fill in the space remaining on top in the recess.

5th Storey, Raised Dome

Projecting slightly with respect to the set-back of the 4th storey transition element, but aligned with it in the lower part, the dome (diam. 9.60) begins; after a vertical section the curvature begins. The facing has been conserved over a large section up to a height of 4.39, while the core continues up to a height of 3.00; the reconstructed h. is 5.50.

The Stairway

There is some uncertainty about the development of the 1st storey stairway, situated on the stream bed, with the fore-building extending into it. It is unlikely that it continued further, turning to one side, parallel with the storey of the stupa to the S or N; it most likely continued forward, in line with the stairway of the 2nd storey, both of which have a narrower than normal width. It can be imagined as being supported by a structure crossing the stream, like a bridge, without impeding the latter's flow, reaching the opposite bank a short distance away at a height corresponding to the structures standing there. The two areas were thus connected by means of an unexceptional solution used in works designed to regulate watercourses, as is frequently documented (Saidu Sharif I, Butkara III, Tokar Dara).

Stupa B

In the area to the left of the stream, stupa B lies at the S end of the substructured western terrace, behind and higher (?) than vihara F. Badly damaged and open to the SW surrounded by mounds of earth, the E side of the 1st storey, quadrangular in plan, is visible (and partially also the others), with its two gradually receding circular storeys, all decorated with pilasters, the second of which may be considered the drum and the composite type dome provided by the transition storey; with the stairway facing NE at the level of the 1st and 2nd storeys. It repeated the pattern already seen in the stupa A, together with the construction technique for the facing and the core. This allows us to avoid a detailed description, which would also be repetitive, simply pointing out the differences.

1st Storey, Quadrangular in Plan

Storey measures: leng. S 10.80; E, W 10.97; h. 3.27. The pilasters are 7 in number, including the corner ones; interaxis 1.80. Traces of the slab paving are visible. The mouldings of the storey and the pilaster are akin to those found in stupa A. Missing from the base moulding are the two upper fillets, set back and protruding, on which the base of the pilaster rests. In the shaft of the pilaster the plaster retains part of the grooving with concave closures at the extremities; in the modillion, there is a row of dentils and strips of equal length placed beneath the upper fillet; this motif recurs in the architrave the stucco of which is divided into two bands. The capital, not conserved in the visible part, displays in the profile of the gap a shape similar to that of stupa A. The upper part of the cornice with reverse ovolo and coping slab is missing as far as the grade level of the 2nd storey. In the stairway the internal and external corner pilasters of the projection are visible as well as a short section of the stairway ramp with the core. The ramp is 2.85 wide; it has 12 steps with an inclination of 41°.

2nd Storey, Circular in Plan

Measures: diam. 8.40; h. 1.86; set back by 1.35 to the S, 1.22 to the W. There are 21 pilasters with an interaxis of 1.13. The base is of the torus type, three-sided beveled with cavetto and four gradually receding fillets, set-back fillet and projecting fillet, on which the pilaster rests. All that is left of this is the base plinth; gaps correspond to the missing parts. A short section of the modillion has been conserved with traces of leaves in the recesses and of architrave band. The stairway, of which only a small section of core remains, can be reconstructed with an external corner pilaster of the projection. It is 2.10 wide, and has 7 steps with an inclination 51°.

3rd Storey, Circular in Plan (Drum)

Measures: set back by 0.95, h. 1.42, diam. 6.37. Pilasters, 24 in number with a width of 0.12 and interaxis of 0.86. We again find the same decorative elements as in the 2nd storey. The missing pilasters and brackets have left gaps. A single pilaster is conserved intact on the right in the painted inset (see below), provided with a capital obtained from a single badly corroded travertine block, the only one conserved. Small traces of the dentil and strip motif in the modillion and the upper part of the architrave are visible, rendered in two zones in the plaster.

In the W section, in the upper part of the space between the two pilasters (width 0.79, h. 0.67), of which the right hand one with the capital has been conserved, the plaster has been conserved on which the remains of painting are visible. In the middle, slightly in relief, it is possible to follow the circle of a large halo that rises in the space between the two modillions; in the centre there is an oblong zone corresponding to a head; lower left there is a curved line that seems to correspond to the right shoulder of the figure. On the right and left of the central halo traces of two smaller halos are visible. Traces of reddish brown colour are visible at the back and surrounding the relief elements.

The scene may be reconstructed as a Buddha figure seated face on with a halo (nimbus?) at the centre and at the sides two smaller, also haloed, figures.

In the groove of the pilasters of this and the 2nd storey, in the graphic reconstruction, the same motif as that observed in the 1st storey is repeated.

4th and 5th Storeys (Composite Dome)

4th Storey, Circular in Plan, Transition Element

It rises slightly, turning inwards at the top, closed by a mortised projecting slab, still conserved, slightly sloping, held by smaller slabs that close the gap on top; socket h. 0.11, depth 0.10, slab projection 0.17.

5th Storey, Raised Dome

Facing conserved up to a h. of 2.35, the core up to a h. of 3.70.

Relic Box

Inside, enclosed in the core is the relic box, of which the N side was conserved (1957) as well as the N side (width 0.45) with a small angle to the W (0.03); nothing is now left owing to a subsequent destruction. The base height was at the same level as the base of the 3rd storey; height indeterminable.

Stupa C

Positioned on the W terrace, aligned with the other buildings, between the vihara D and the series of smaller buildings; part of the 1st storey is buried on the W side facing the mountain. Deeply split in the middle from one side to the other down to the 1st storey. It comprises a storey that is quadrangular in plan, two gradually receding circular bodies, all decorated with pilasters, the second of which may be considered the drum and the dome; stairway to the N, linked to the 1st storey. Overall layout, decorative elements, facing technique and core structure are the same as in stupas A and B.

1st Storey, Quadrangular in Plan

Measures at the storey: leng. E 13.42, W 13.60, S 12.85, h. 4.13. There are 7 pilasters, including the corner ones, with an interaxis of 2.125. Visible mainly to the E and in the corner of the stairway projection, situated on the N side. In the mouldings of the stupa base and cornice and in the pilasters the profiles observed in stupa A are repeated with slight variations; in particular in the block structure of the capital, with undulating laterally flaring profile, with a circular projection on the front of the abacus, visible in the N corner; it appears as a Gandharan-Corinthian capital. The dentil and strip stucco decoration on the modillion and the architrave is repeated; small leaves in the lateral recess of the modillion; in the shaft of the pilasters groove terminating in a straight line below; the upper one is concave as in stupa A with the edges of the recess made of two set-back fillets. The reconstructed stairway is 3.00 wide and consists of 16 steps having an inclination of 40°.

2nd Storey, Circular in Plan and 3rd Storey, Circular in Plan (Drum)

Respectively set back are the 2nd storey by 1.50 to the S and 1.37 to the W and the 3rd storey by 1.12; the 2nd measures h. 2.18 and diam. 10.12, the 3rd h. 1.665 and diam. 7.90. They both have the wall divided by 24 pilasters with an interaxis of 1.325 in the 2nd and 1.00 in the 3rd. The profiles observed in stupas A and B are repeated. The stupa base is of the torus type, with a two slab torus; the base of the pilasters is of the scotia type. The same decorative elements are repeated in the modillion, with a small leaf in the socket, and in the architrave. The reconstruction repeats the grooves with the same profile. Note should be taken here of the decorative rendering technique: dentils and strips are applied to the surface of the graffito plaster. Red colour residues in the recesses.

A. Stupas

4th and 5th Storey (Composite Dome)

4th Storey, Circular in Plan, Transition Element

Slightly set back from the plumb line of the wall of the 3rd storey. It rises with the base supported by a short projecting slab in the structure, curving slightly at the top. It is closed in at the top by a row of projecting slabs (0.18) inserted in the cavity (socket) (h. 0.09, depth 0.11), held firm by small slabs on top which fill in the gap in the cavity in accordance with the usual system. Measures: h. 0.98, diam. 7.65.

5th Storey, Raised Dome

The beginning of the dome is flush with the cavity; facing conserved up to a h. of 3.25 and the core for a total h. of 4.10.

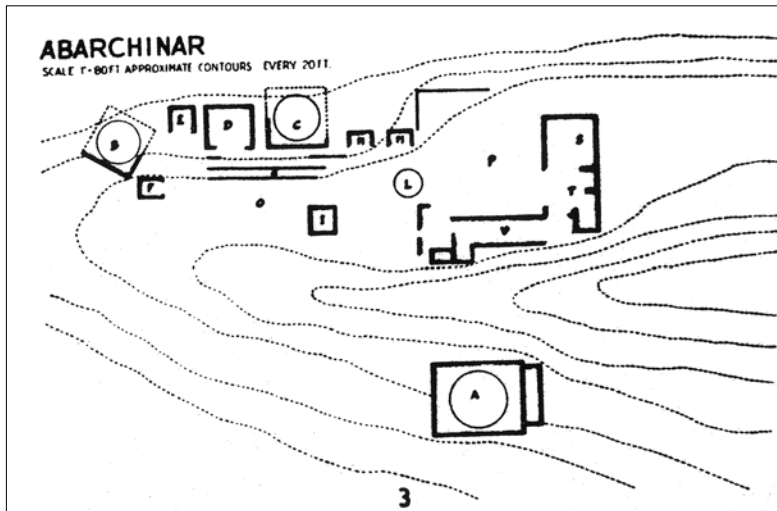

Fig. 217.
Abbasahebchina.
General sketch plan
of the complex. (After
Barger & Wright 1941:
tav. XI.3).

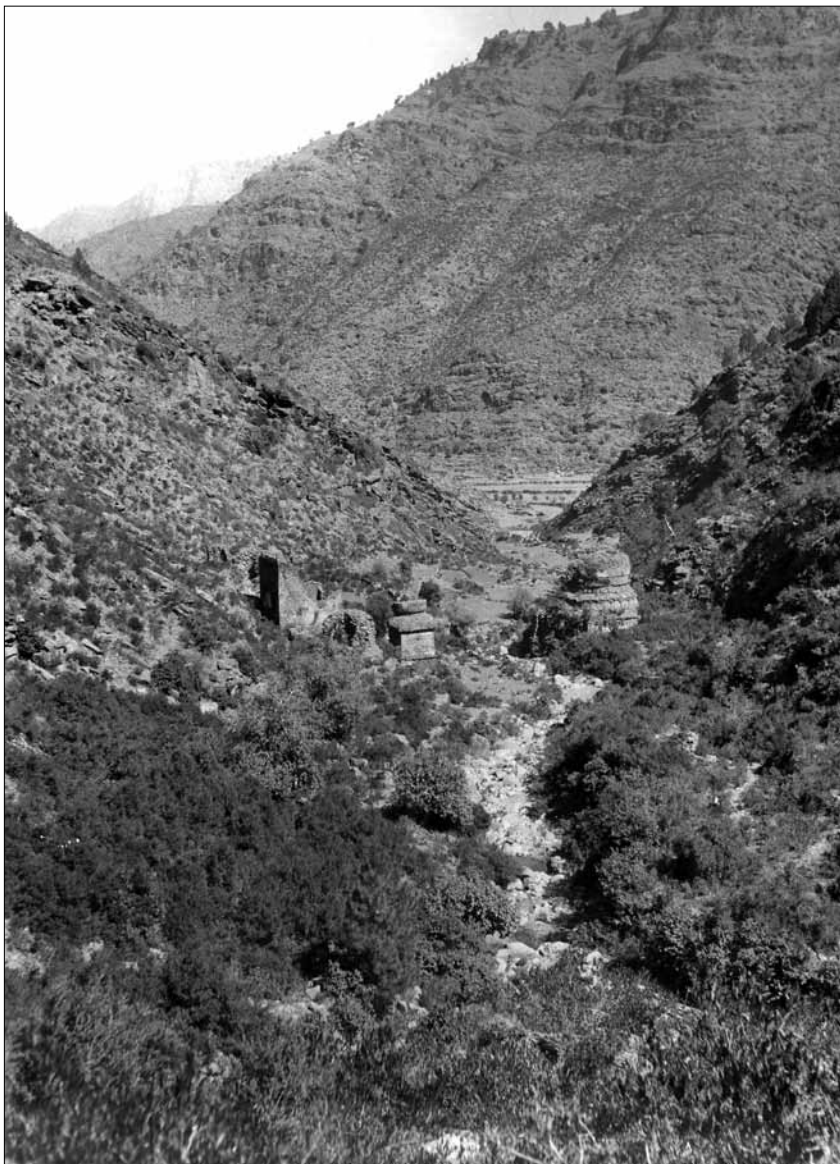

Fig. 218.
Abbasahebchina.
General view
from S. (Taddei
1957; Neg. 21/16).

A. Stupas



Fig. 219. Abbasahbchina. General view from N. (Spagnesi 2005).



Fig. 220. Abbasahbchina. Vihara D. (Spagnesi 2005).



Fig. 221.
Abbashehchina.
Monastery hall
with windows;
inner view. (After
Tucci 1958: fig. 29).



Fig. 222. Abbashehchina. Partial planimetry, with heights. (Sabelli 1993; Martore 2003).

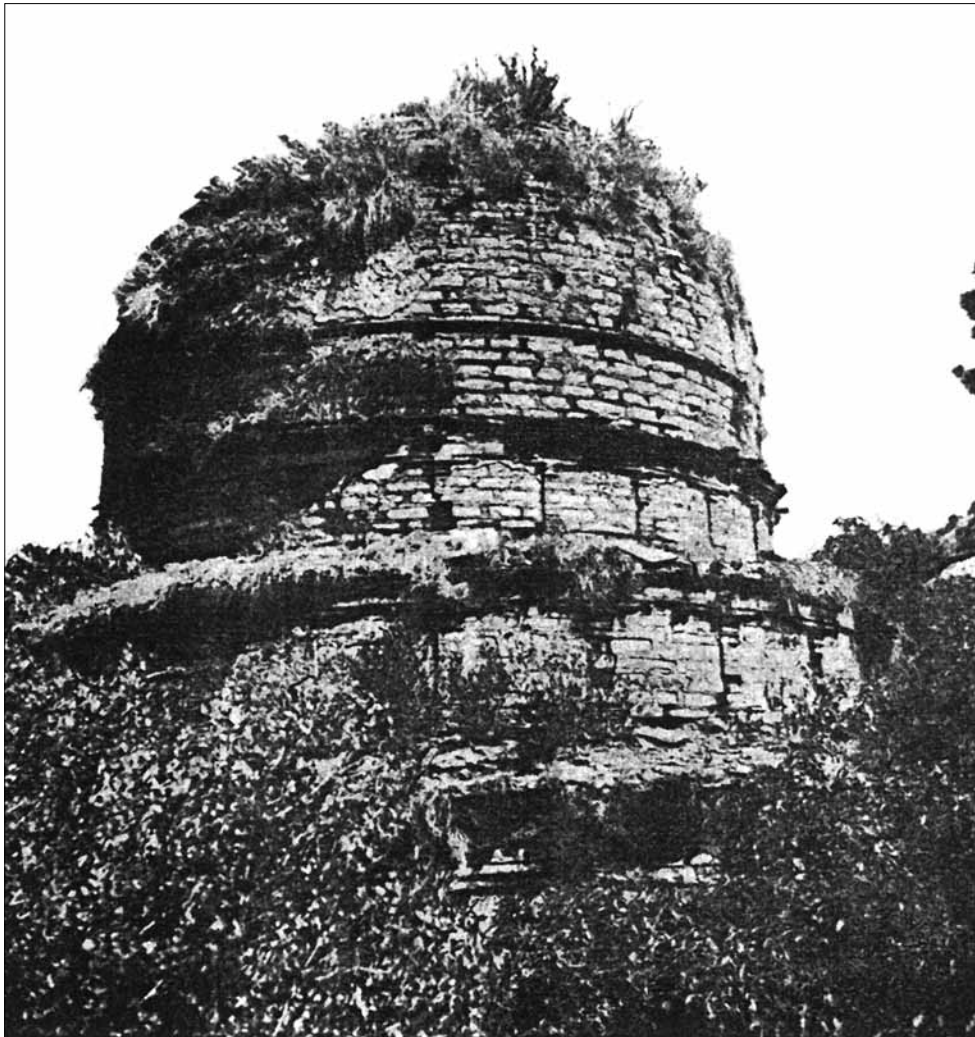

Fig. 223. Abbasahebchina. Stupa A. S side. (After Tucci 1958: fig. 27).

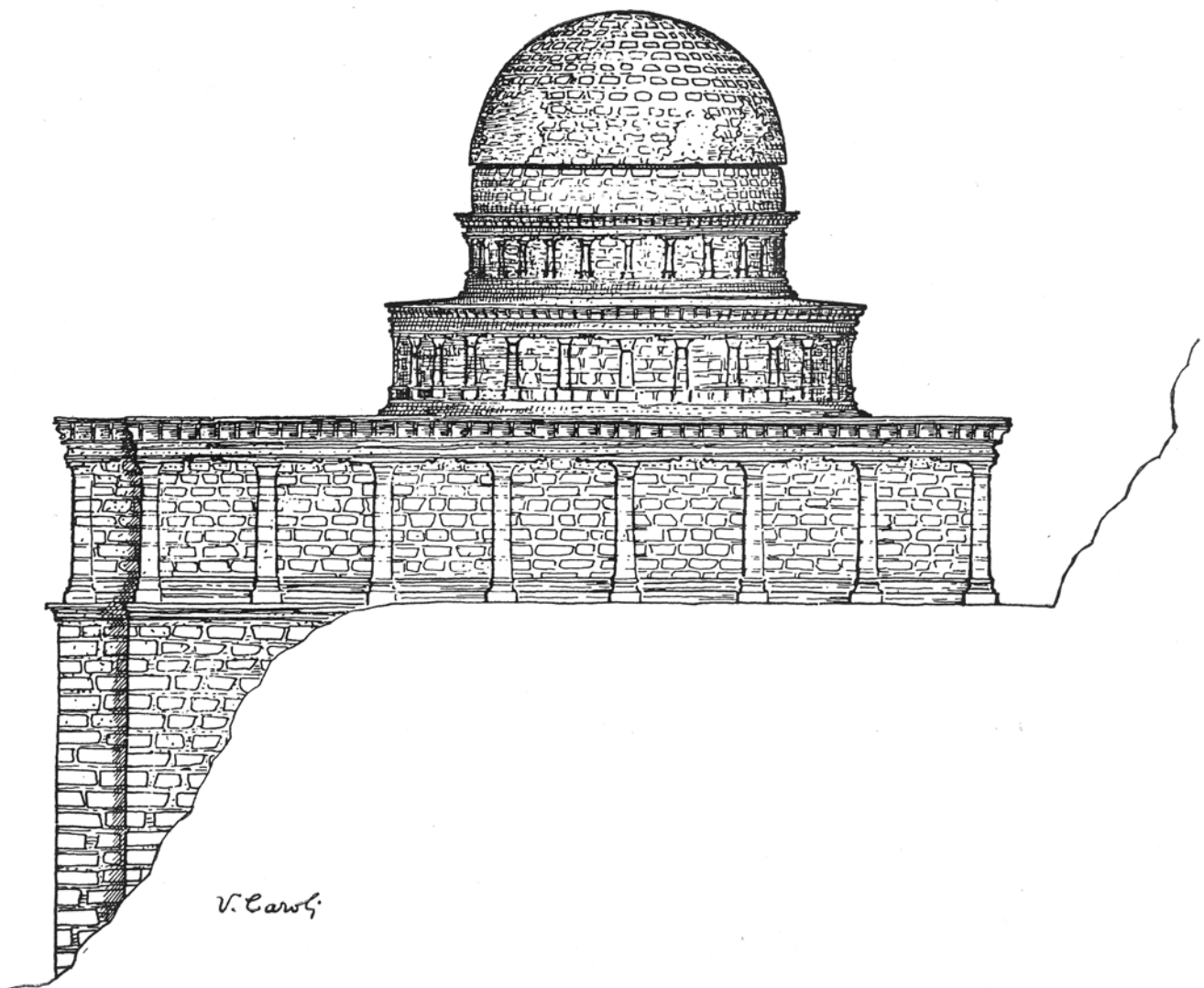

Fig. 224. Abbasahebchina. Stupa A. S side elevation. (After Tucci 1958: fig. 31; drawing by Cairoli).

A. Stupas

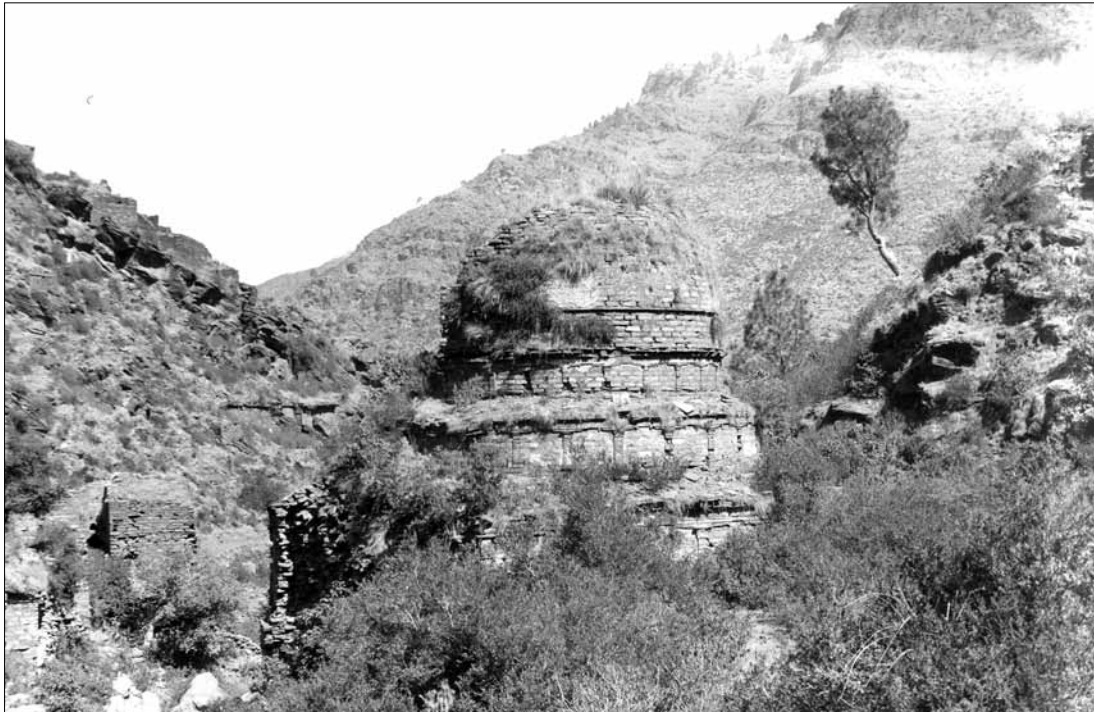

Fig. 225. Abbasahebchina. Stupa A. General view, S side. (Taddei 1957; Neg. CS).



Fig. 226. Abbasahebchina. Stupa A. SE side view. (Kuwayama 1993).



Fig. 227.
Abbasahebchina.
Stupa A. N
side view.
(Kuwayama
1993).



Fig. 228. Abbasahebchina. Stupa A. N and W side, view from NW corner. (Spagnesi 2005).

A. Stupas



Fig. 229. Abbasahebchina. Stupa A. W side. (Kuwayama 1993).



Fig. 230. Abbashehchina. Stupa A. W side, 1st storey, N projection and the stairway core. (Kuwayama 1993).

A. Stupas



Fig. 231. Abbasahebchina. Stupa A. W side, N projection and the stairway core.
(Kuwayama 1993).

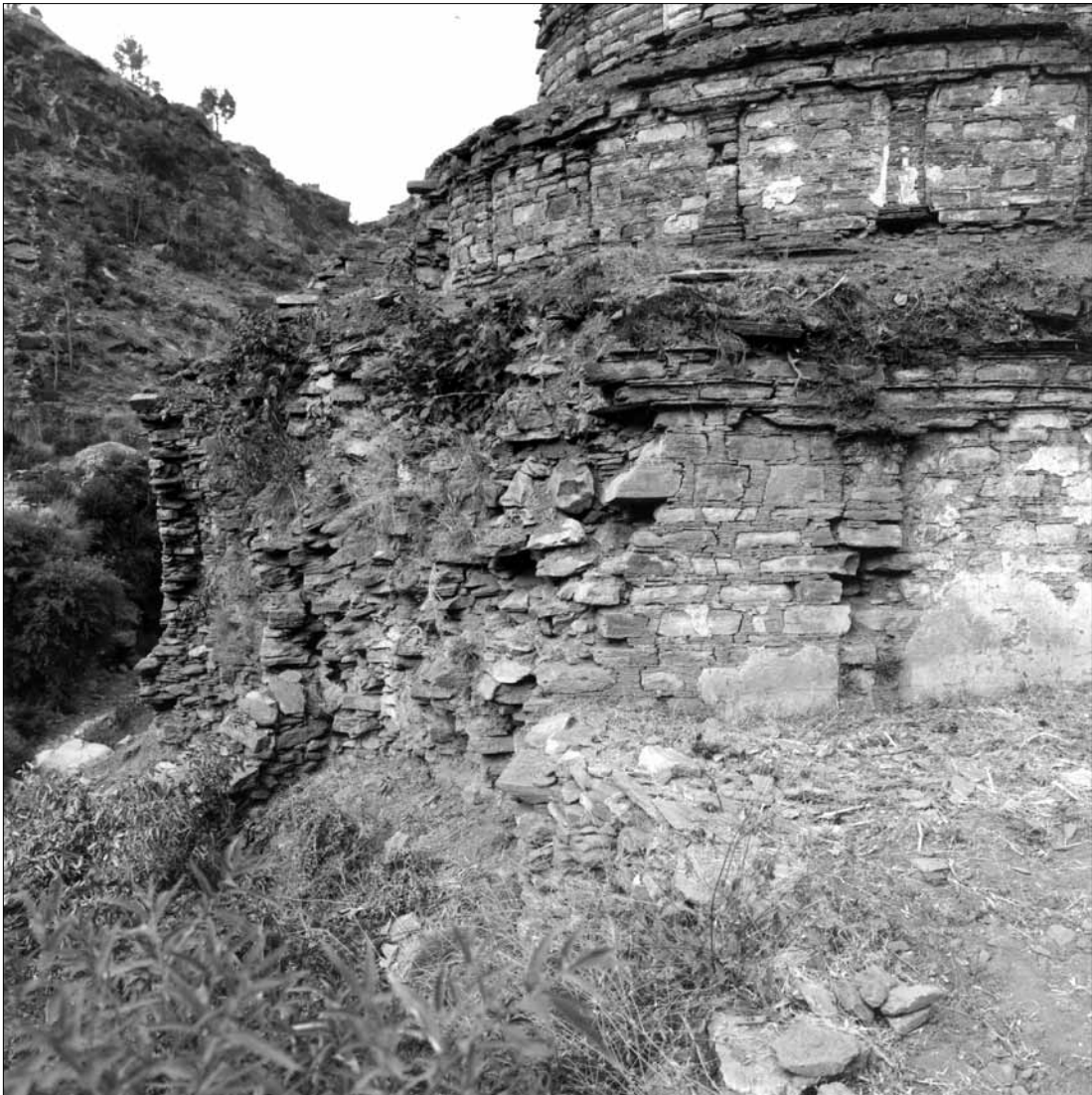

Fig. 232. Abbasahbchina. Stupa A. S side, 1st storey, with remains of plaster.
(Kuwayama 1993).



Fig. 233. Abbasahebchina. Stupa A. S side, 1st storey, with remains of plaster. (Kuwayama 1993).



Fig. 234. Abbasahbchina. Stupa A. N side, 1st storey, with remains of plaster.
(Kuwayama 1993).

A. Stupas



Fig. 235. Abbasahebchina. Stupa A. N side, 1st storey, with remains of plaster.
(Kuwayama 1993).



Fig. 236. Abbasahchina. Stupa A. S side, 2nd storey. (Kuwayama 1993).

A. Stupas



Fig. 237. Abbasahebchina. Stupa A. S side, 2nd storey, with remains of plaster. (Kuwayama 1993).

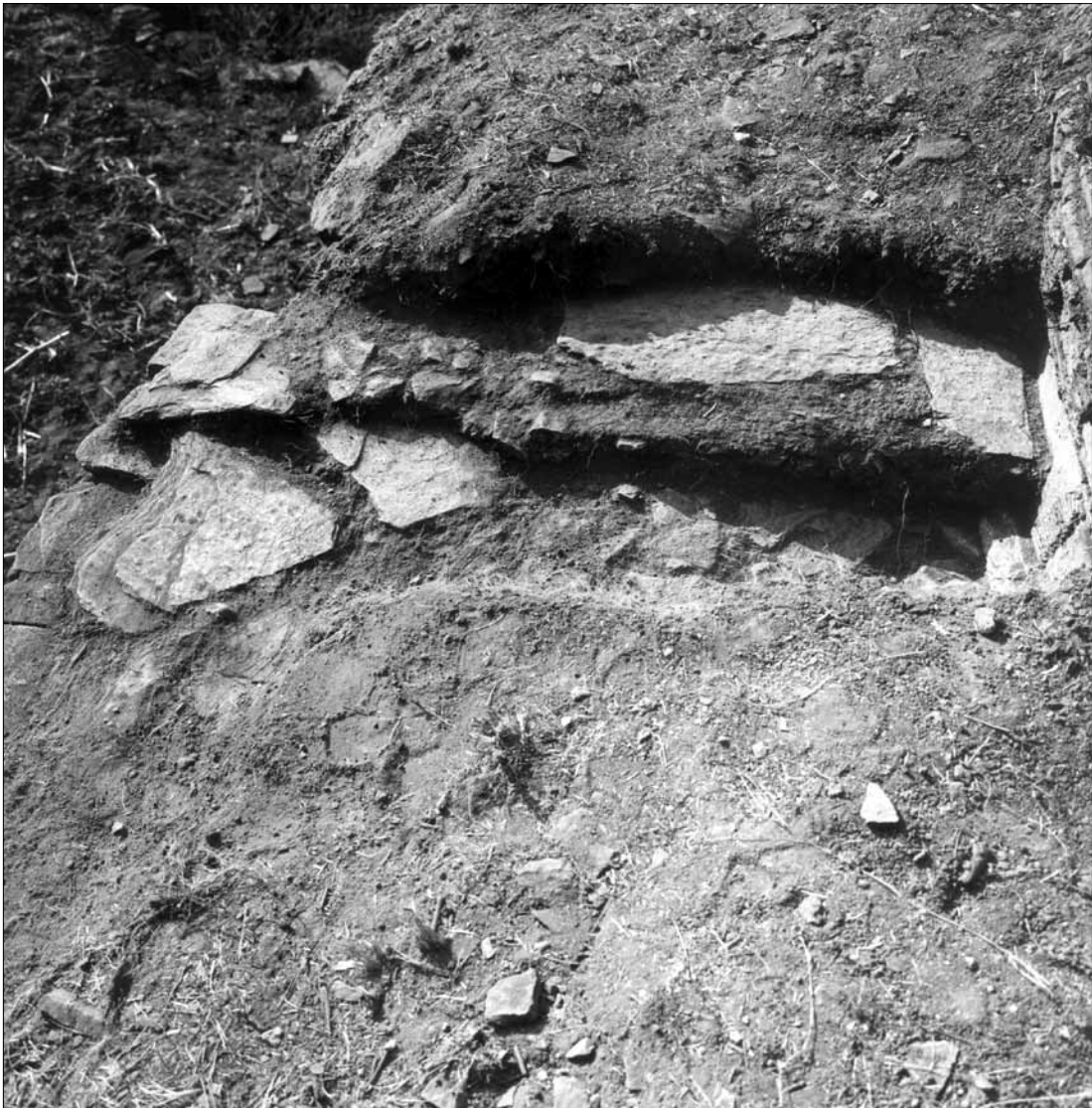

Fig. 238. Abbasahebchina. Stupa A. N side, 2nd storey, trial trench with different floor levels. (Kuwayama 1993).

A. Stupas



Fig. 239. Abbasahebchina. Stupa A. S side, 2nd storey, with remains of plaster; 3rd storey (drum) and 4th storey (transition storey of the composite dome). (Kuwayama 1993).



Fig. 240. Abbashehchina. Stupa A. Lato SE side, 3rd storey (drum), 4th storey (transition storey of the composite dome), 5th storey (raised dome); with remains of plaster. (Kuwayama 1993).

A. Stupas



Fig. 241. Abbasahebchina. Stupa A. 3rd storey (drum), 4th storey (transition storey of the composite dome); with remains of plaster. (Kuwayama 1993).

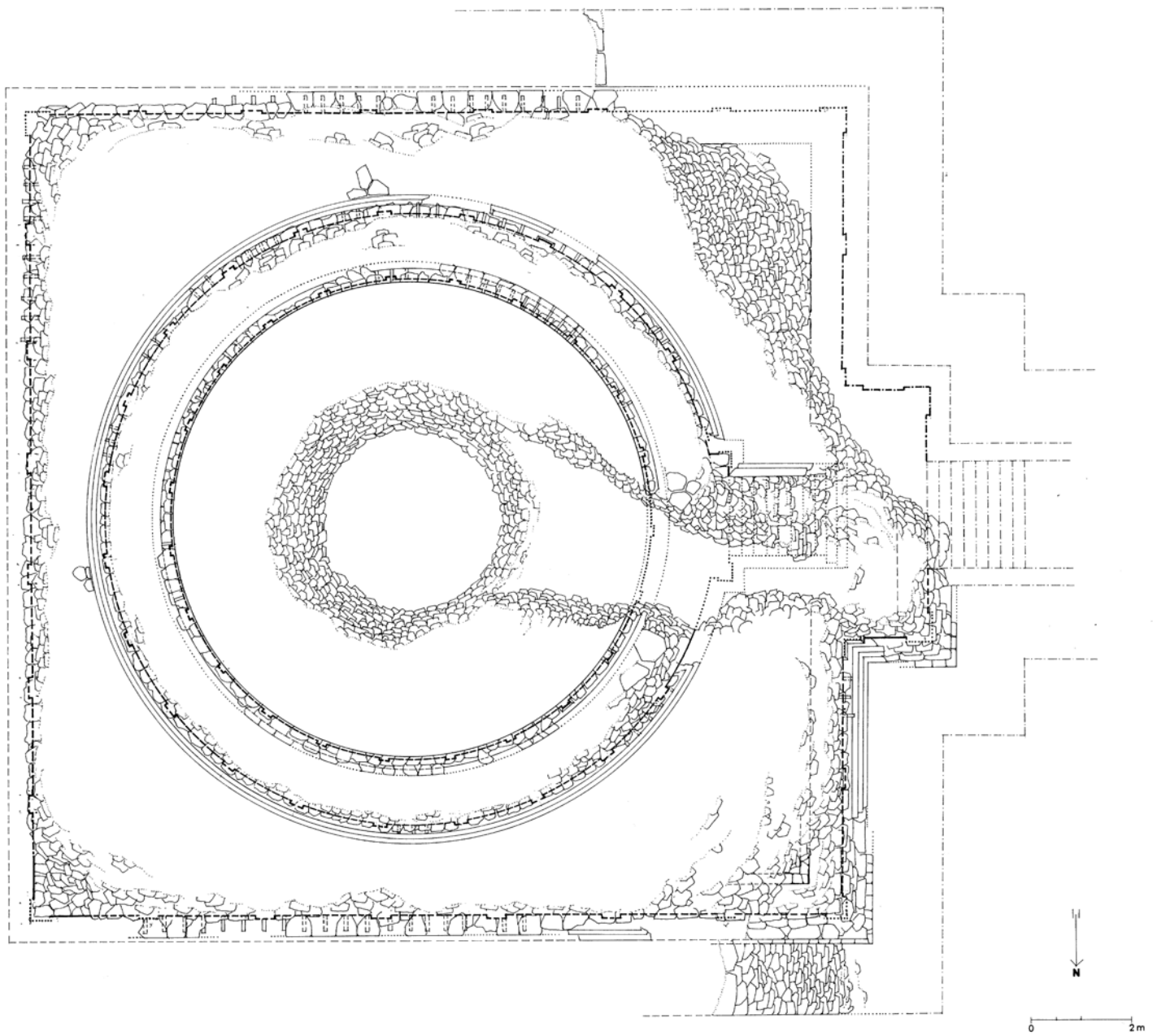

Fig. 242. Abbashehchina, Stupa A. Plan. (Sabelli 1993; Martore 2003).

A. Stupas



Fig. 243. Abbasahebchina, Stupa A. E-W cross section. (Sabelli 1993; Martore 2003).

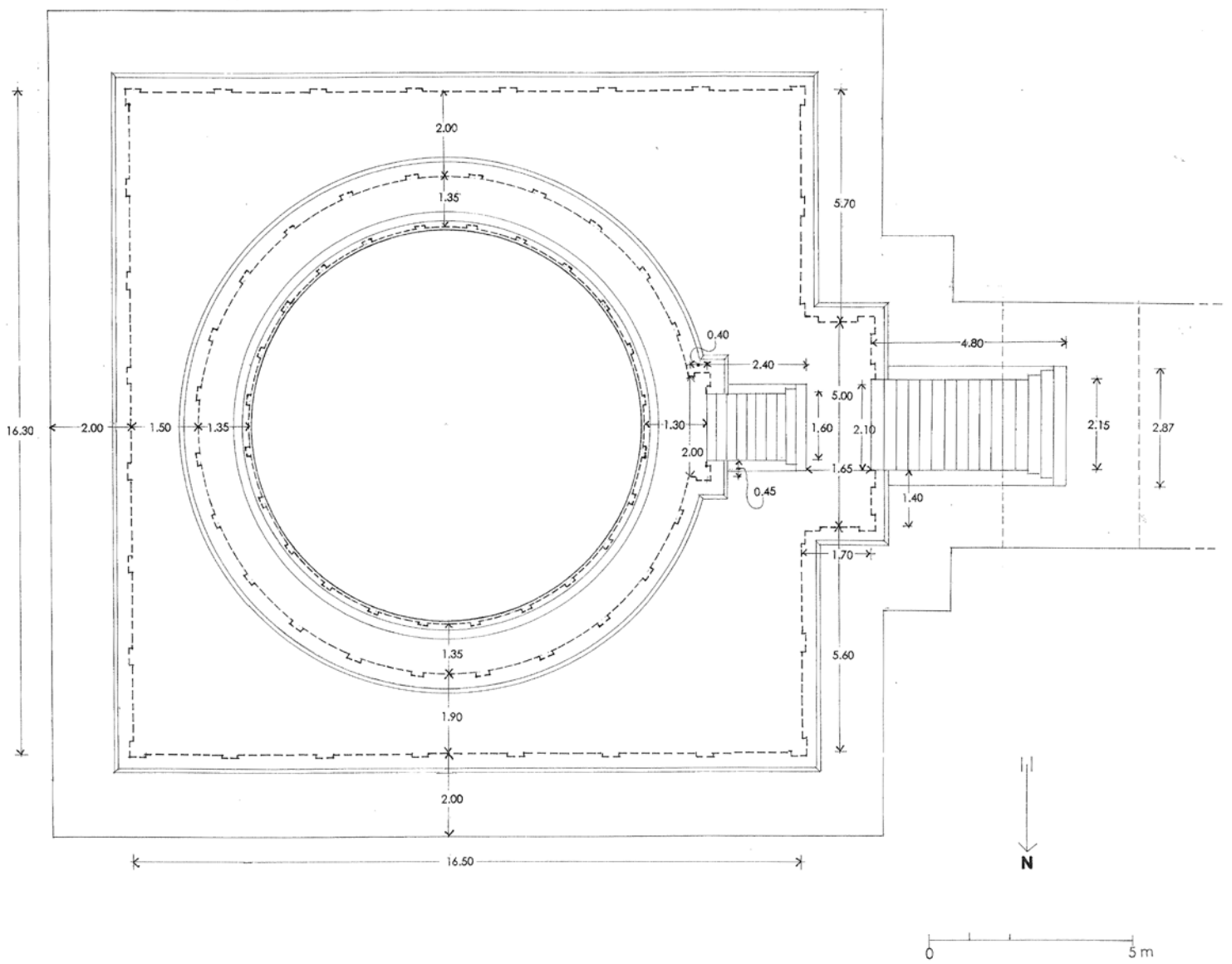

Fig. 244. Abbashehchina, Stupa A. Sketch plan showing the measures. (Martore 2003).

A. Stupas

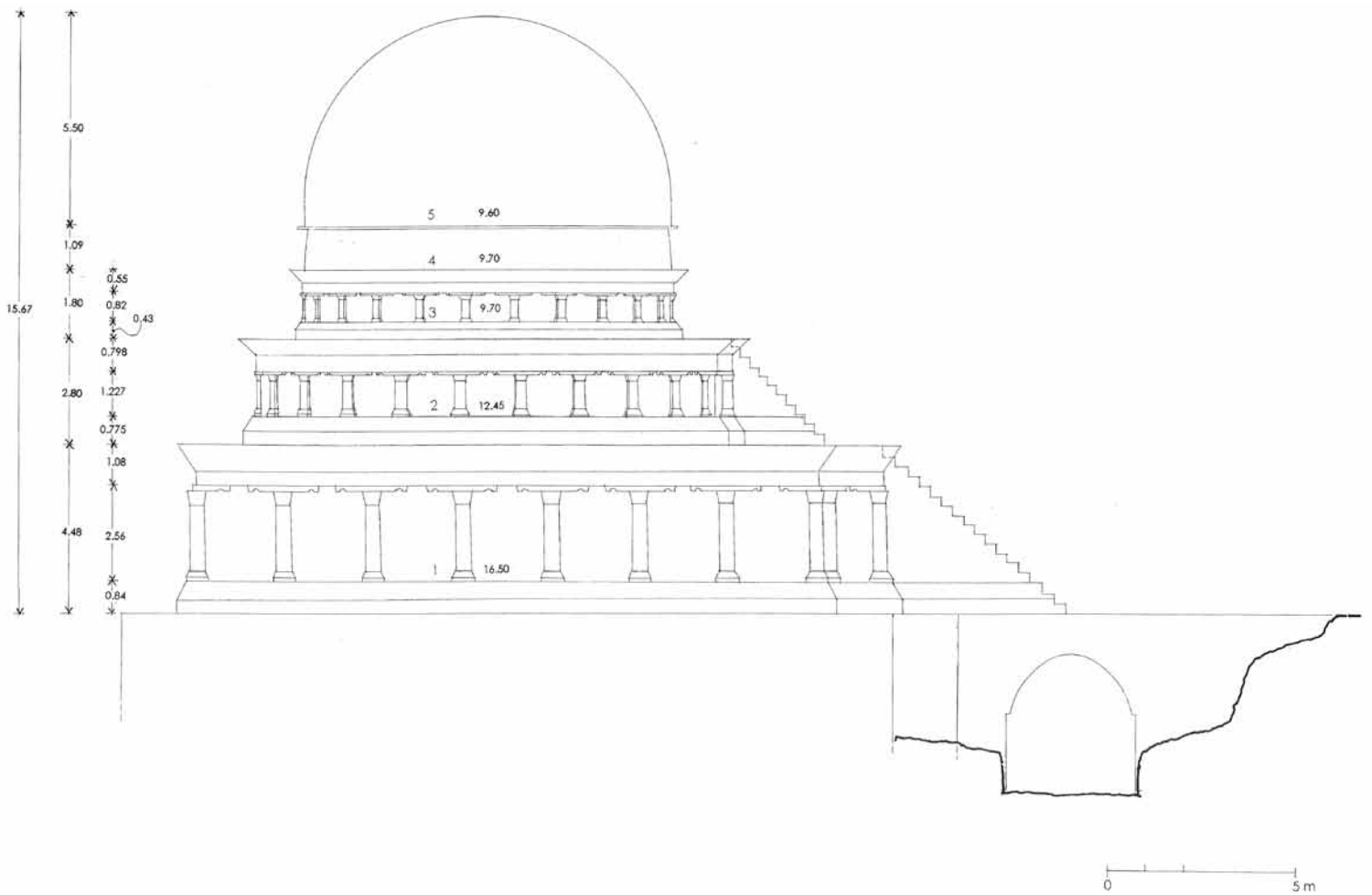

Fig. 245. Abbasahbchina, Stupa A. Sketch elevation showing the measures. (Martore 2003).

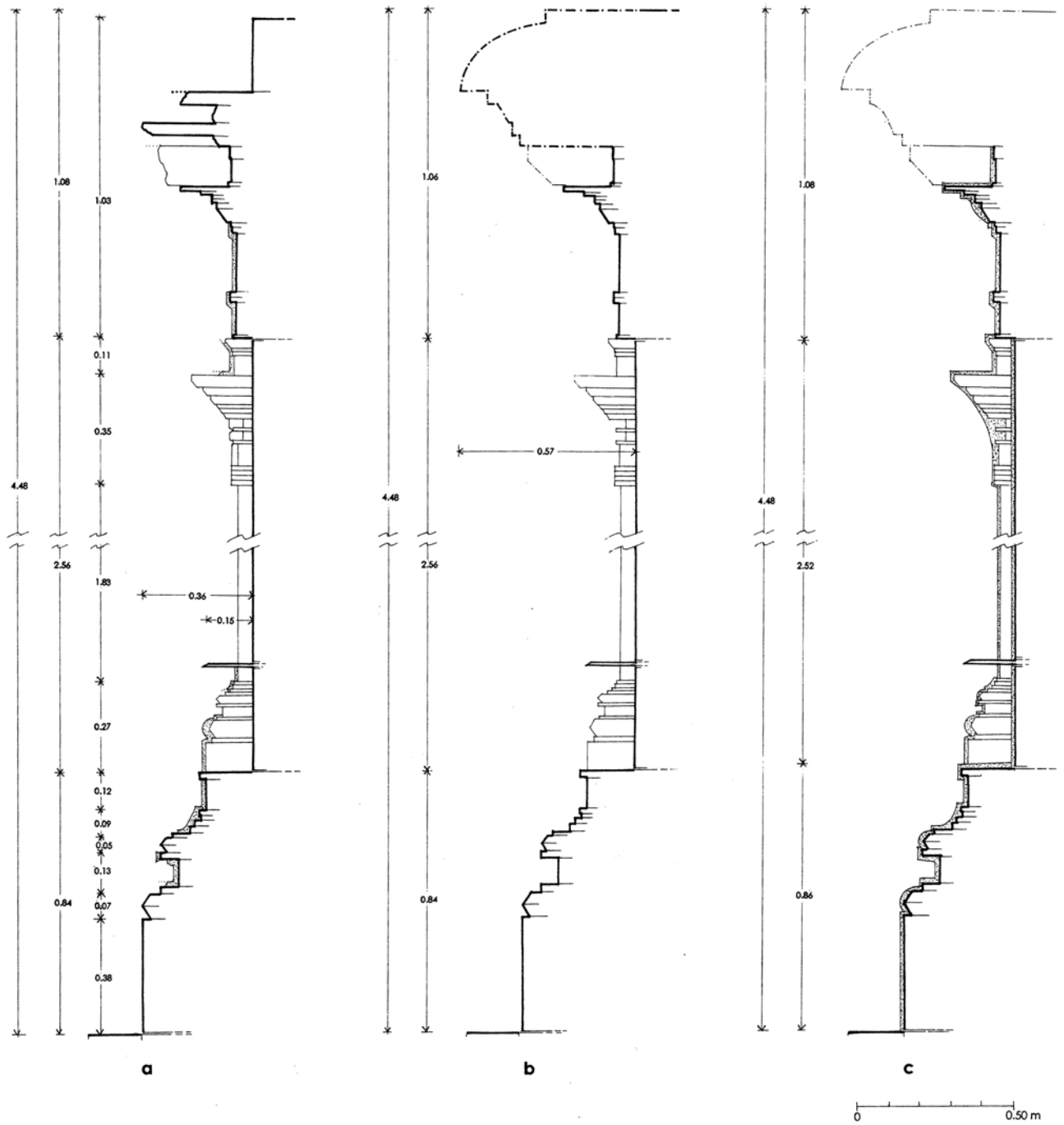

Fig. 246. Abbasahebchina, Stupa A. 1st storey. *a.* profile. *b.* reconstructed profile, without plaster. *c.* reconstructed profile, with plaster. (Sabelli 1993; Martore 2003).

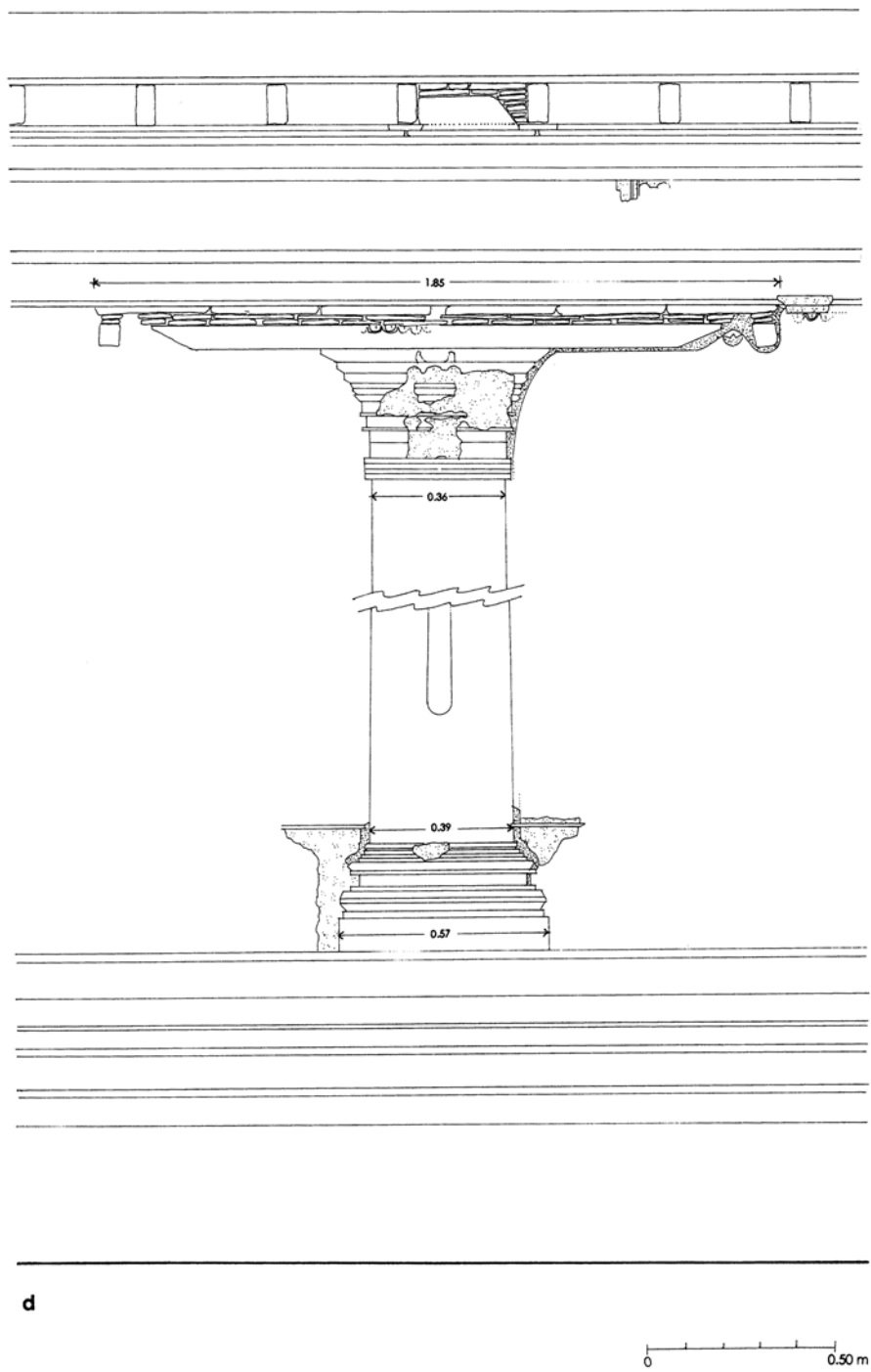

Fig. 247. Abbasahbchina, Stupa A. 1st storey. *d.* elevation showing base, pilaster and cornice. (Sabelli 1993; Martore 2003).

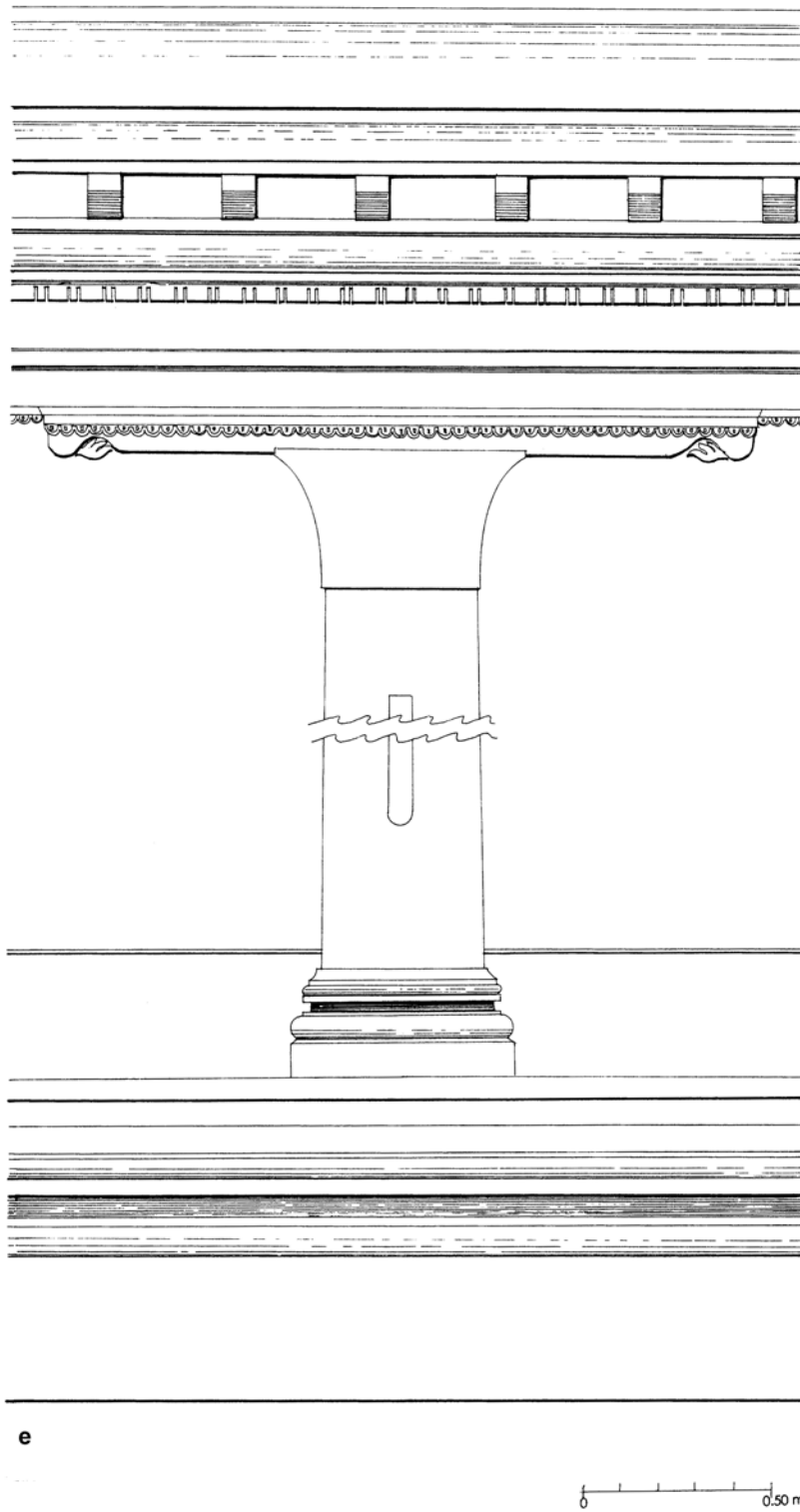

Fig. 248. Abbasahebchina, Stupa A. 1st storey. *e*. reconstructed elevation showing base, pilaster and cornice. (Sabelli 1993; Martore 2003).

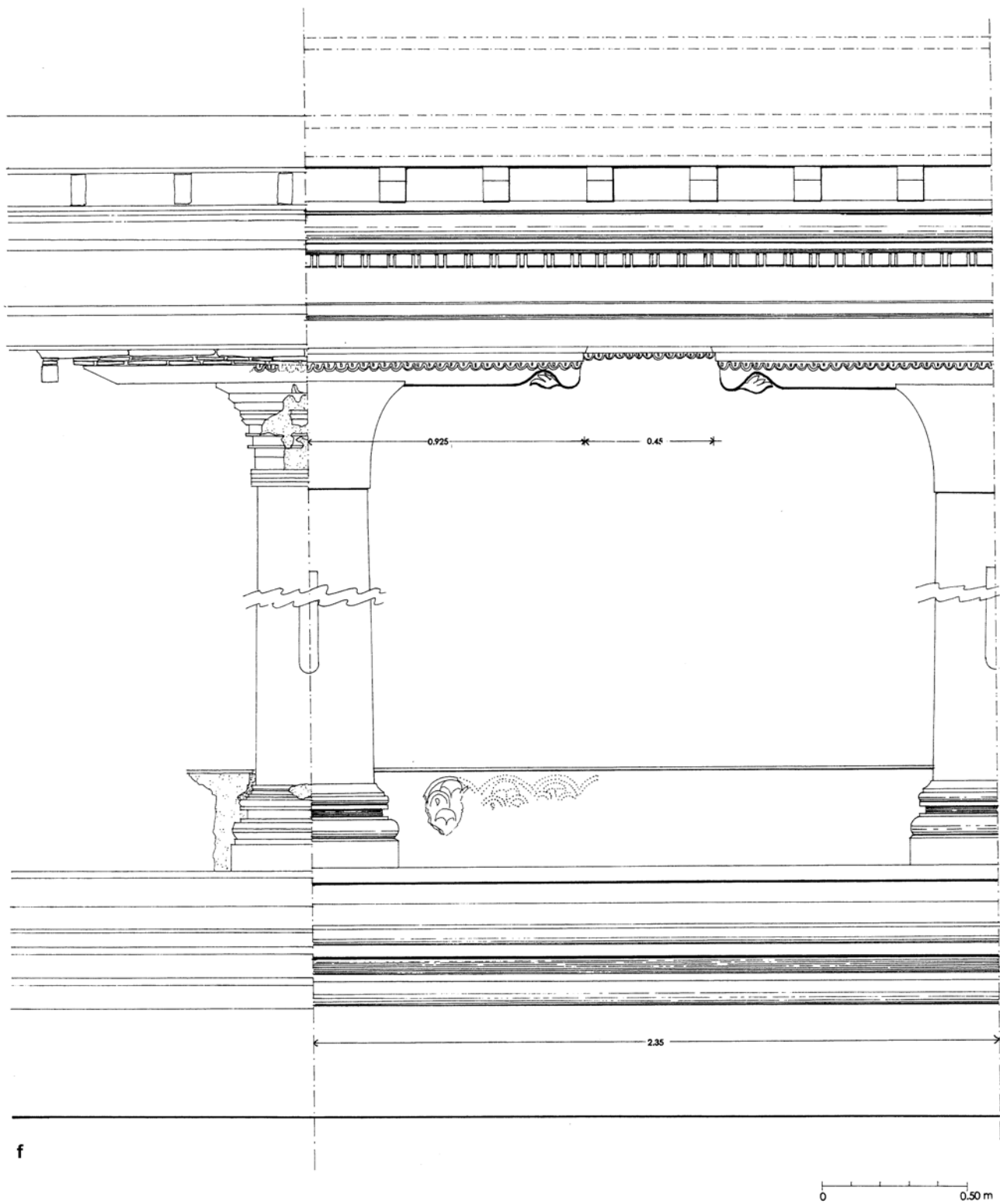

Fig. 249. Abbasahbchina, Stupa A. 1st storey. *f.* actual and reconstructed elevation showing base, interaxis between two pilasters and cornice; traces of pictorial decoration in the lower part of the field inset. (Sabelli 1993; Martore 2003).

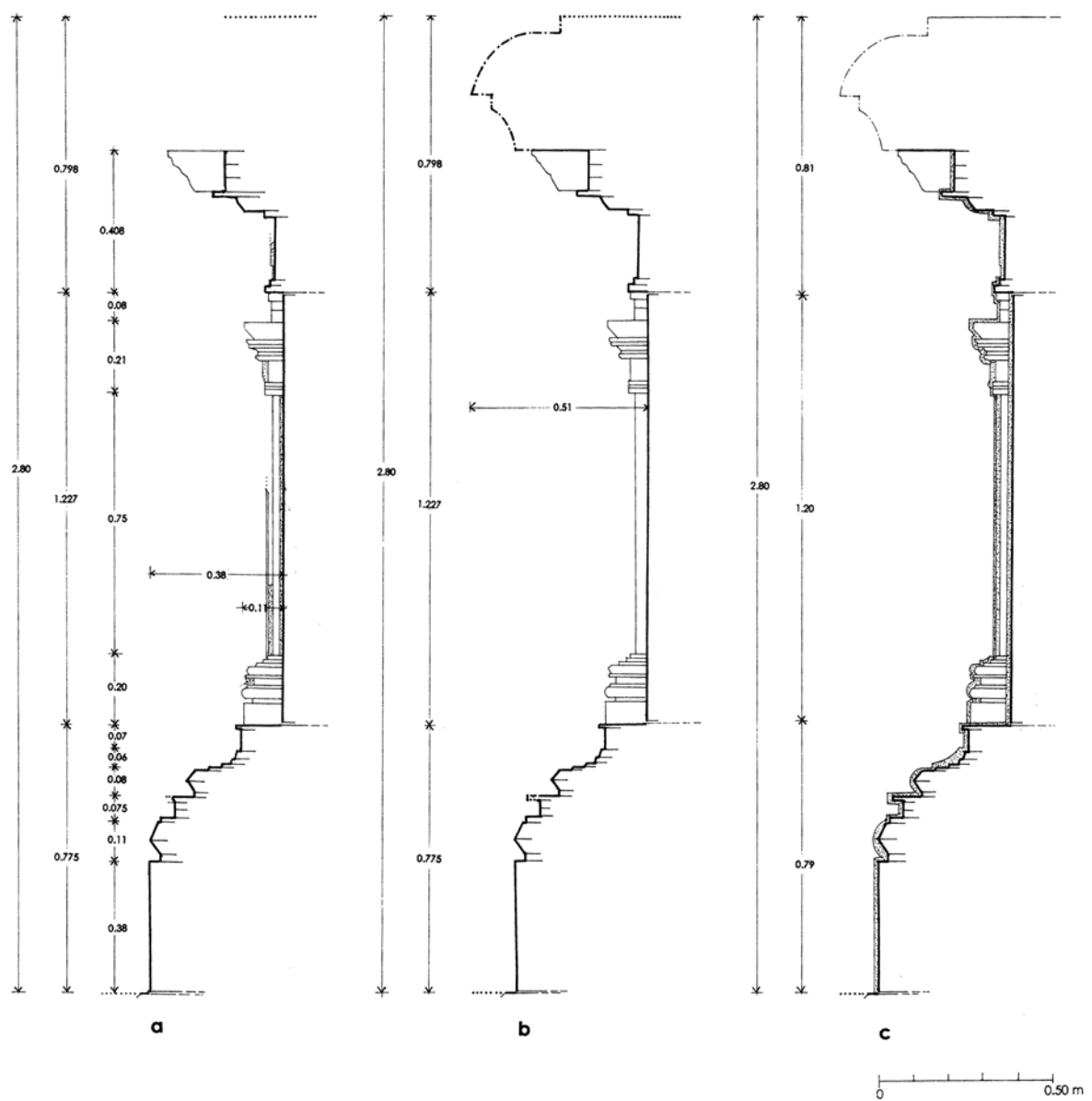

Fig. 250. Abbasahbchina, Stupa A. 2nd storey. *a.* profile. *b.* reconstructed profile, without plaster. *c.* reconstructed profile, with plaster. (Sabelli 1993; Martore 2003).

A. Stupas

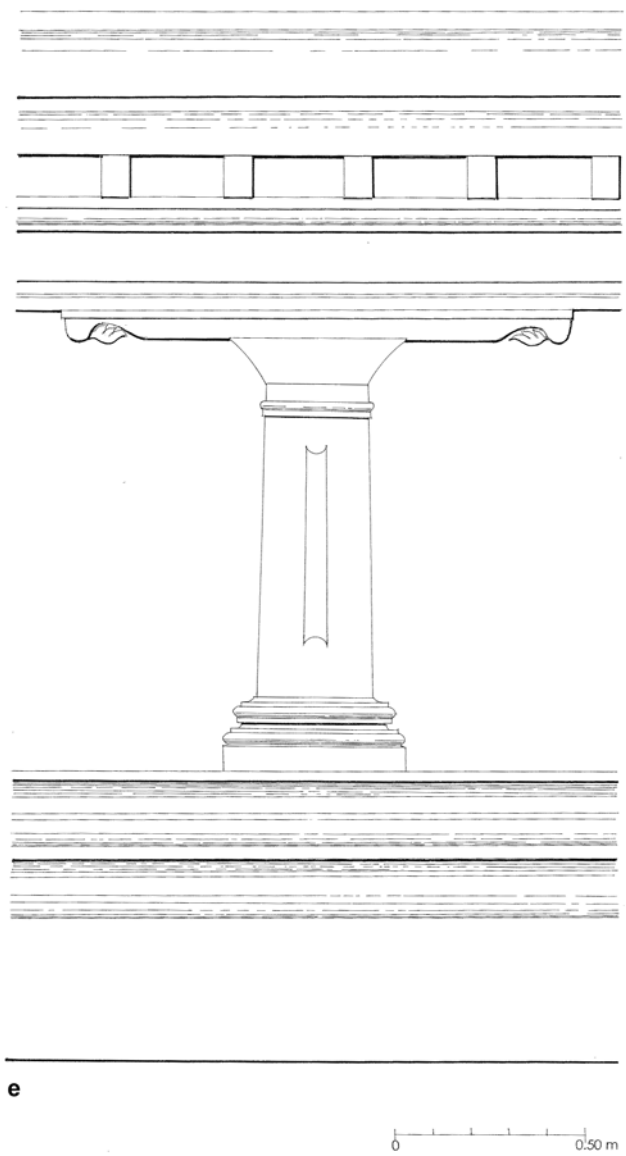
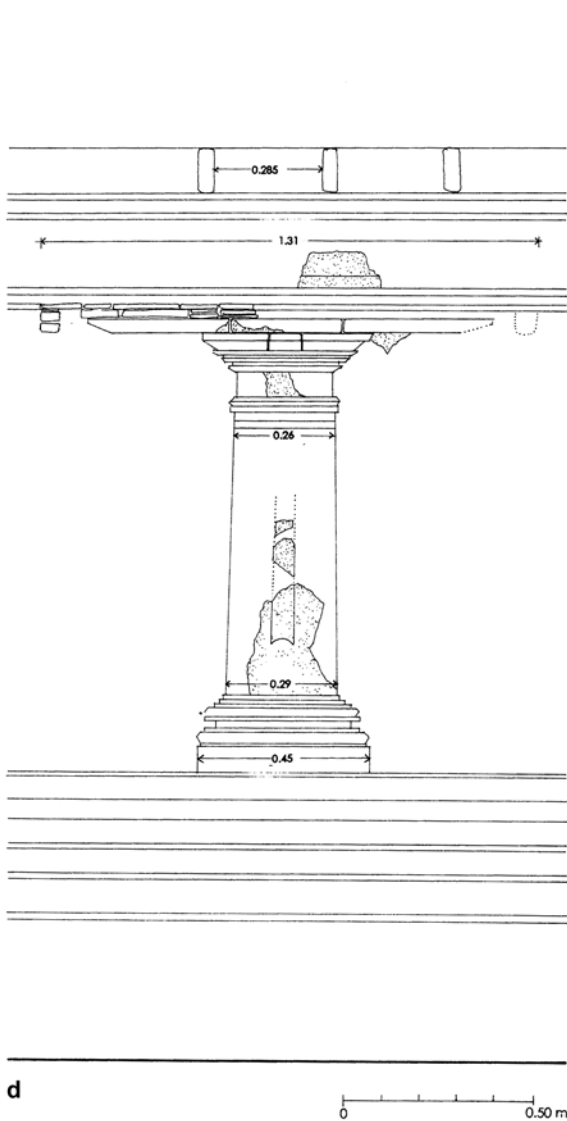

Fig. 251. Abbasahbchina, Stupa A. 2nd storey. *d.* elevation showing base, pilaster and cornice. *e.* reconstructed elevation showing base, pilaster and cornice. (Sabelli 1993; Martore 2003).

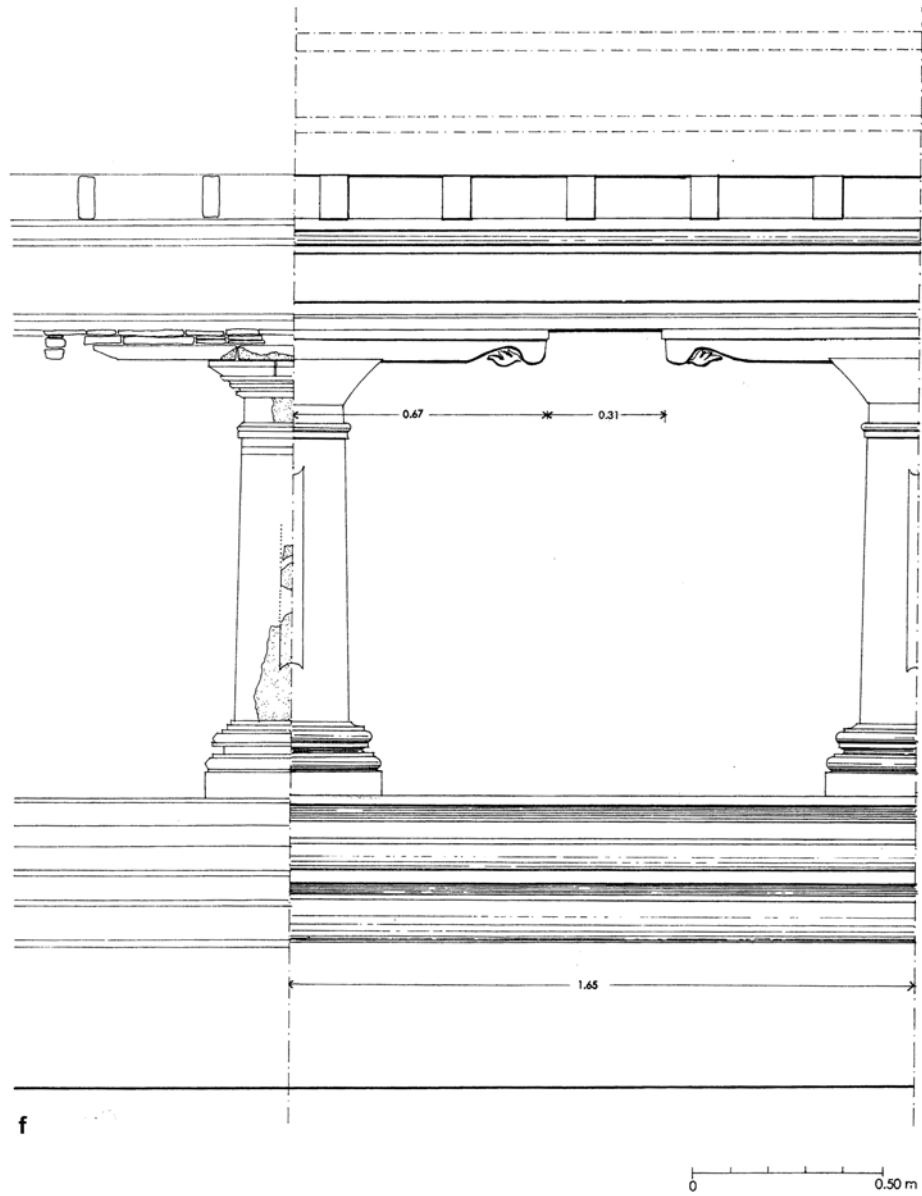

Fig. 252. Abbashehchina, Stupa A. 2nd storey. *f.* actual and reconstructed elevation showing base, interaxis between two pilasters and cornice. (Sabelli 1993; Martore 2003).

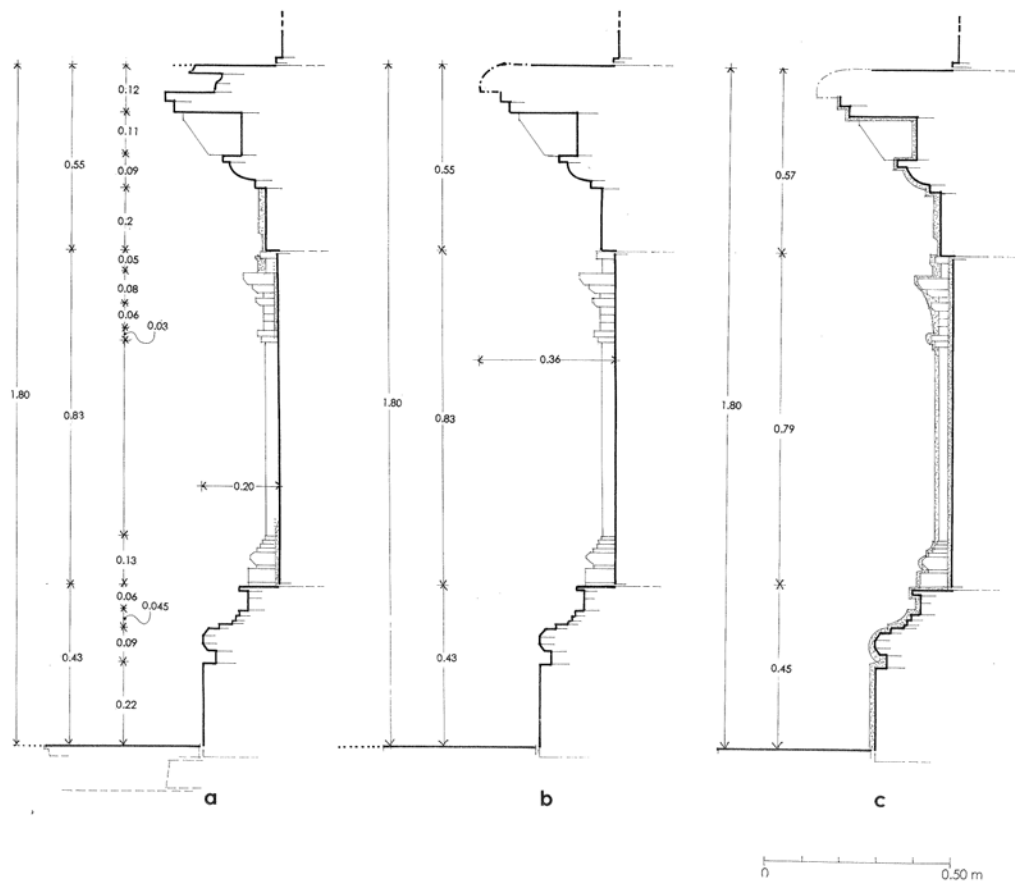

Fig. 253. Abbasahbchina, Stupa A. 3rd storey (drum). *a.* profile. *b.* reconstructed profile, without plaster. *c.* reconstructed profile, with plaster. (Sabelli 1993; Martore 2003).

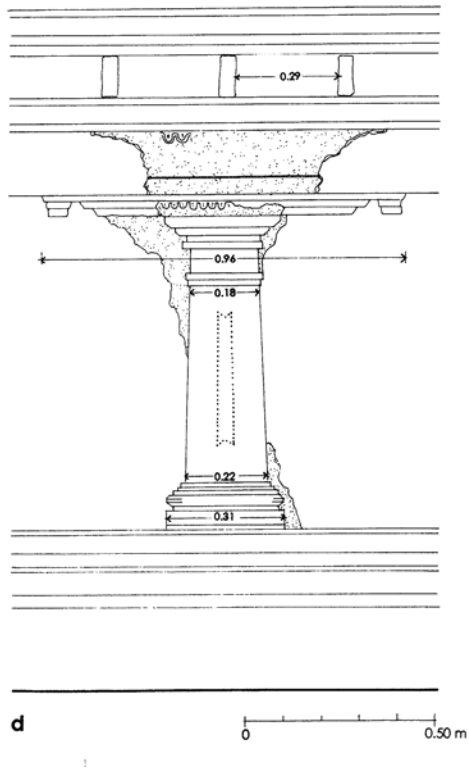

Fig. 254. Abbasahbchina, Stupa A. 3rd storey (drum). *d.* elevation showing base, pilaster and cornice. (Sabelli 1993; Martore 2003).

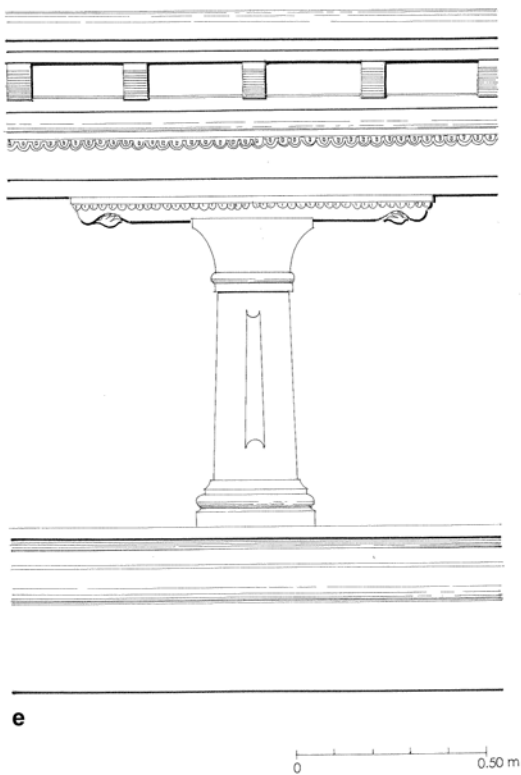

Fig. 255. Abbasahbchina, Stupa A. 3rd storey (drum). *e.* reconstructed elevation showing base, pilaster and cornice. (Sabelli 1993; Martore 2003).

A. Stupas

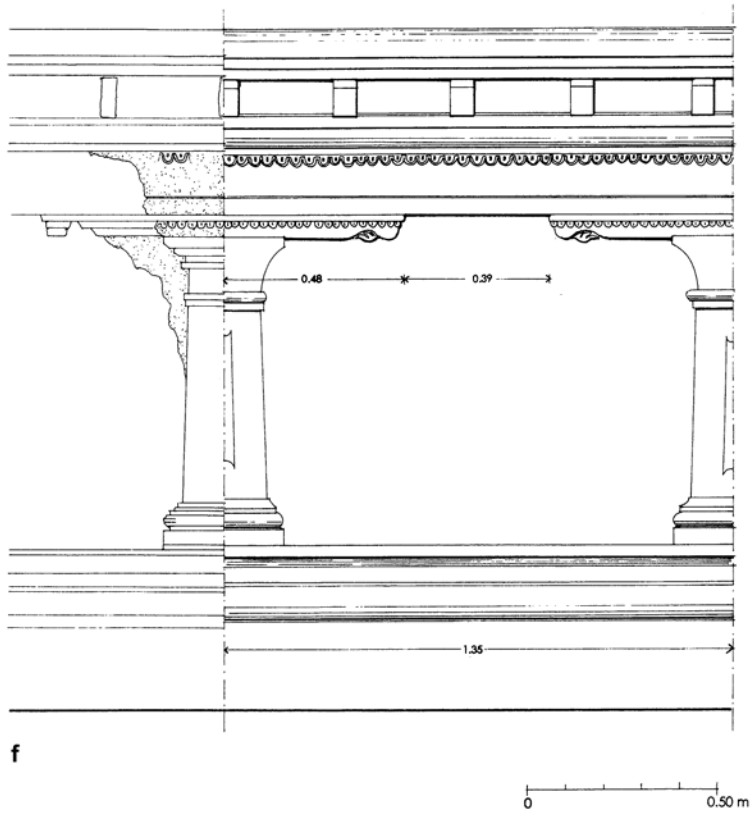

Fig. 256.
Abbashehchina,
Stupa A. 3rd storey
(drum). *f.* actual
and reconstructed
elevation showing
base, interaxis
between two
pilasters and
cornice. (Sabelli
1993; Martore 2003).

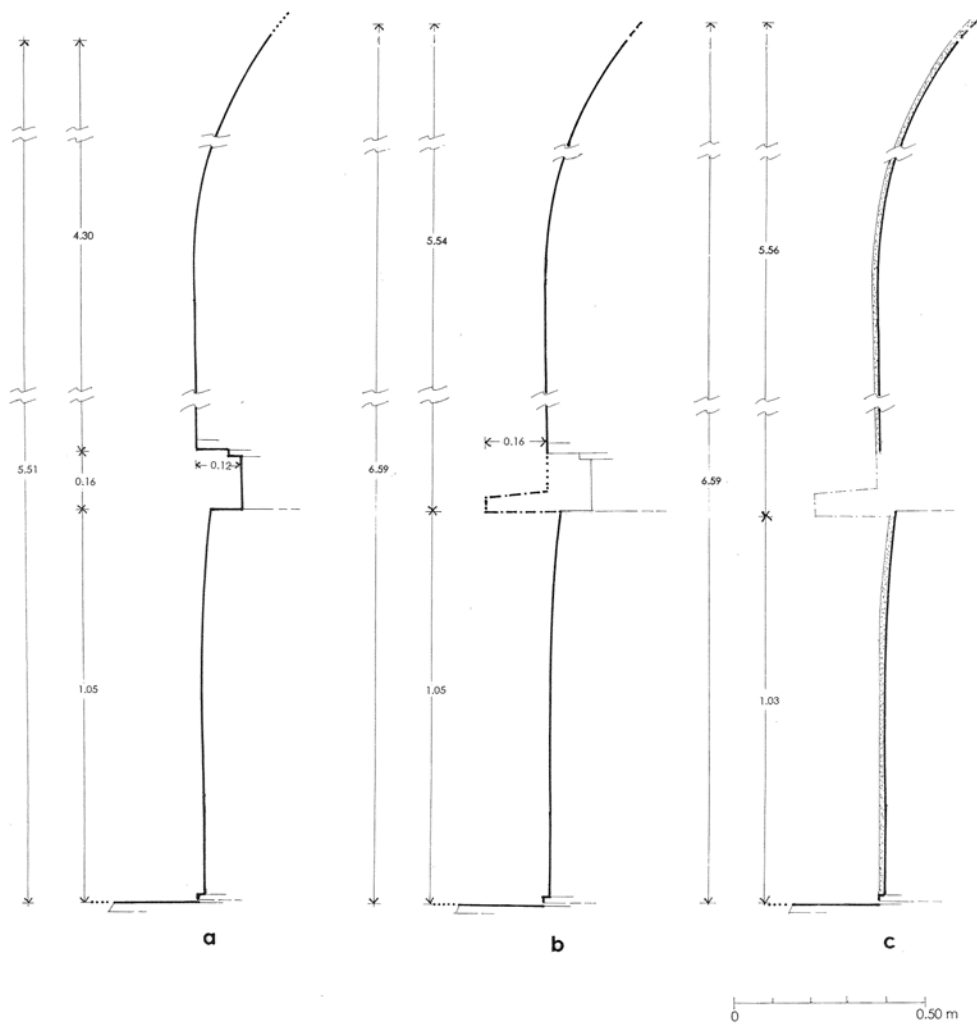

Fig. 257. Abbasahchina, Stupa A. 4th and 5th storey. *a.* profile of the composite dome: 4th transition storey, with socket for the cornice projecting slabs; 5th storey: raised dome. *b.* 4th and 5th storey, reconstructed profile, without plaster, of the composite dome; 4th transition storey with cornice with projecting slabs; 5th storey: raised dome. *c.* 4th and 5th storey, reconstructed profile, with plaster, of the composite dome; 4th transition storey with cornice with projecting slabs; 5th storey: raised dome. (Sabelli 1993; Martore 2003).

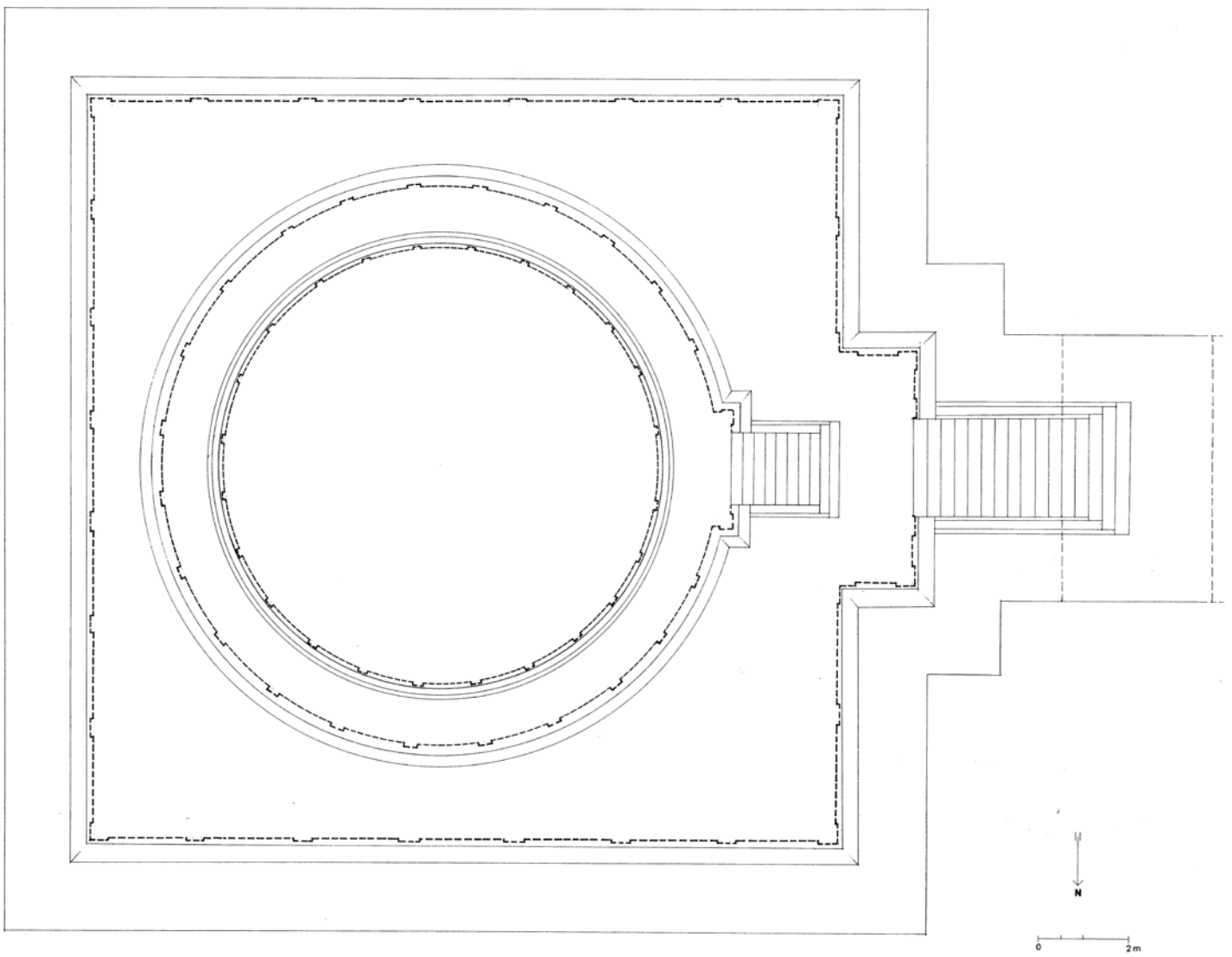

Fig. 258. Abbasahebchina, Stupa A. Reconstructed plan. (Sabelli 1993; Martore 2003).

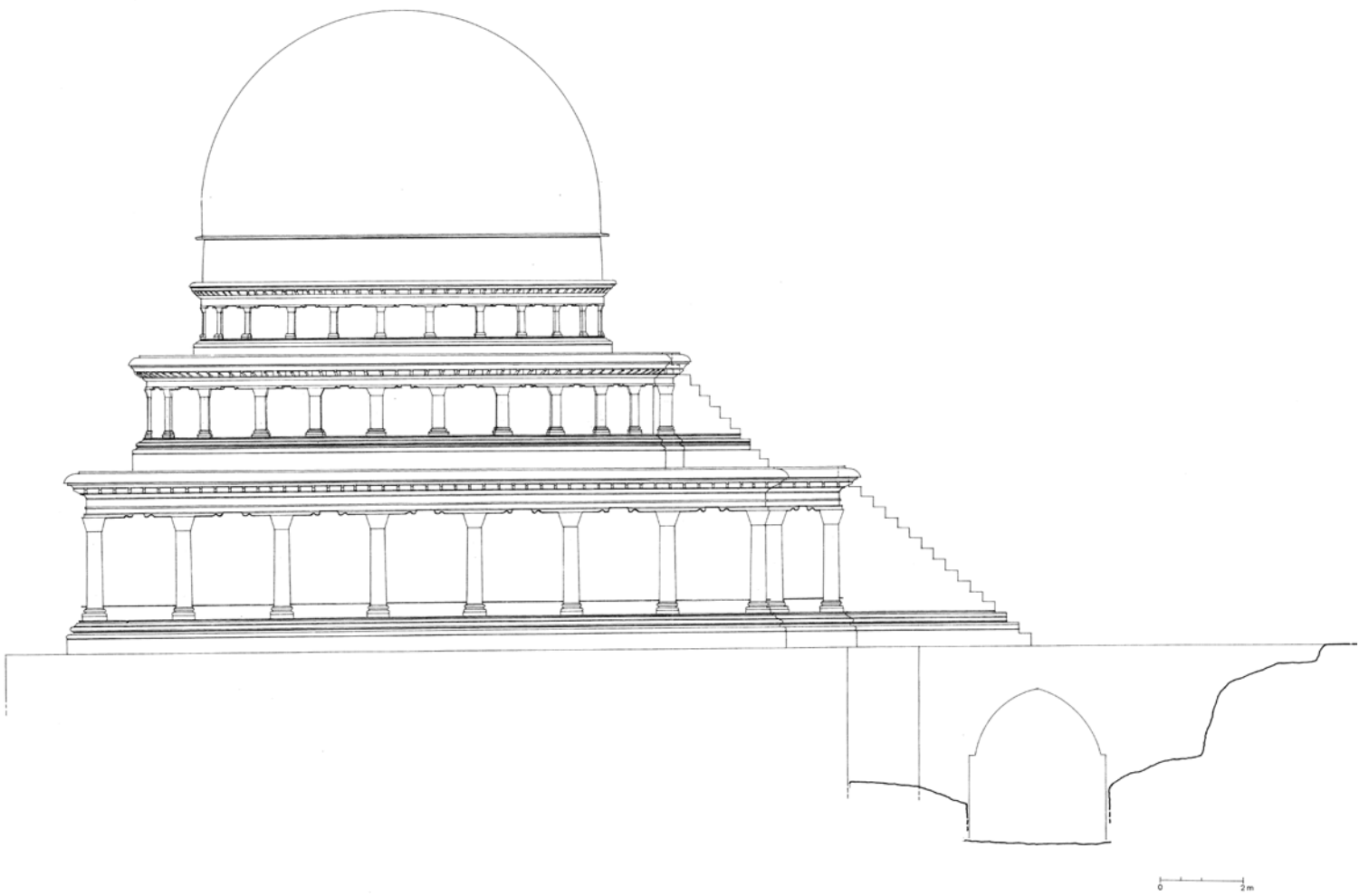

Fig. 259. Abbashehchina, Stupa A. Reconstructed elevation. (Sabelli 1993; Martore 2003).

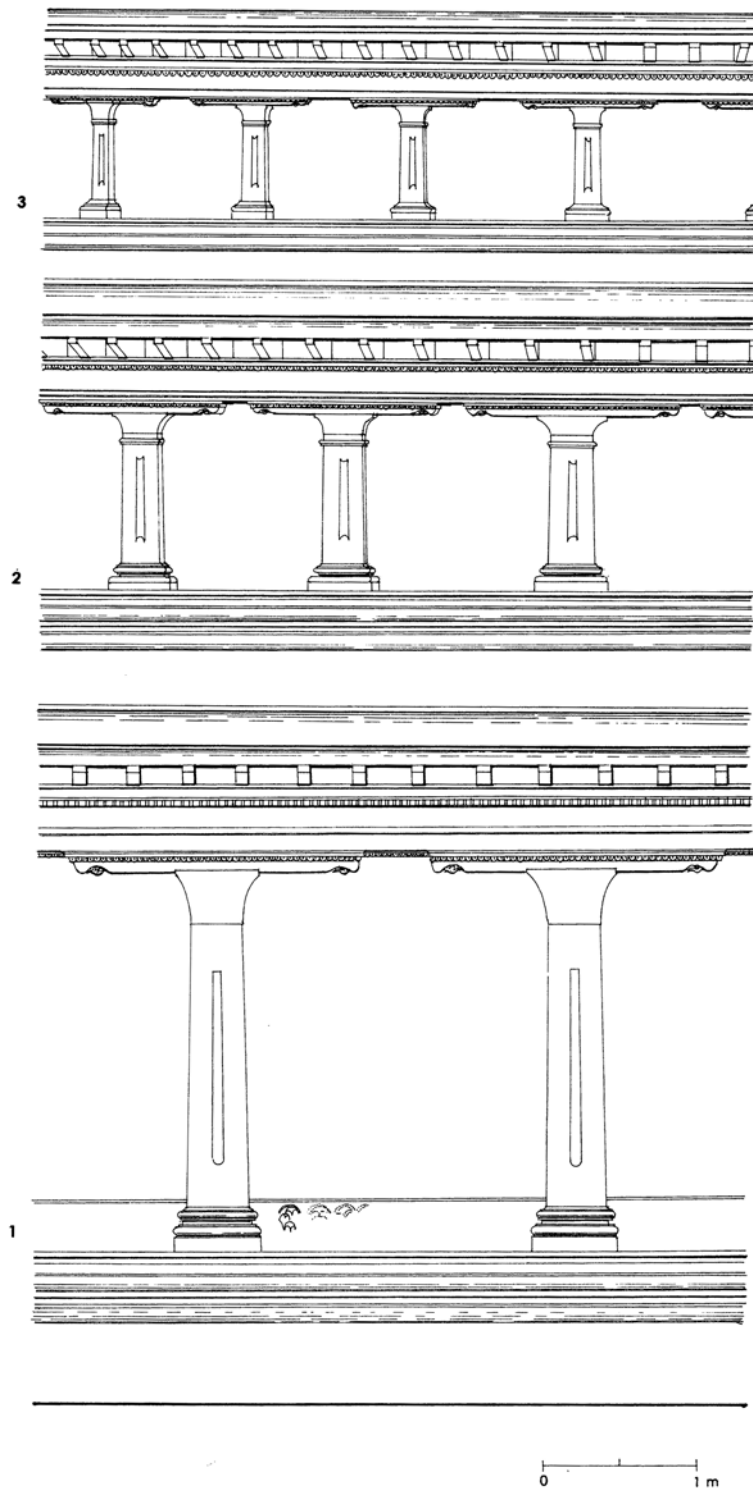

Fig. 260. Abbashehchina, Stupa A. Reconstruction of a stretch of the 1st, 2nd, 3rd storeys. (Sabelli 1993; Martore 2003).

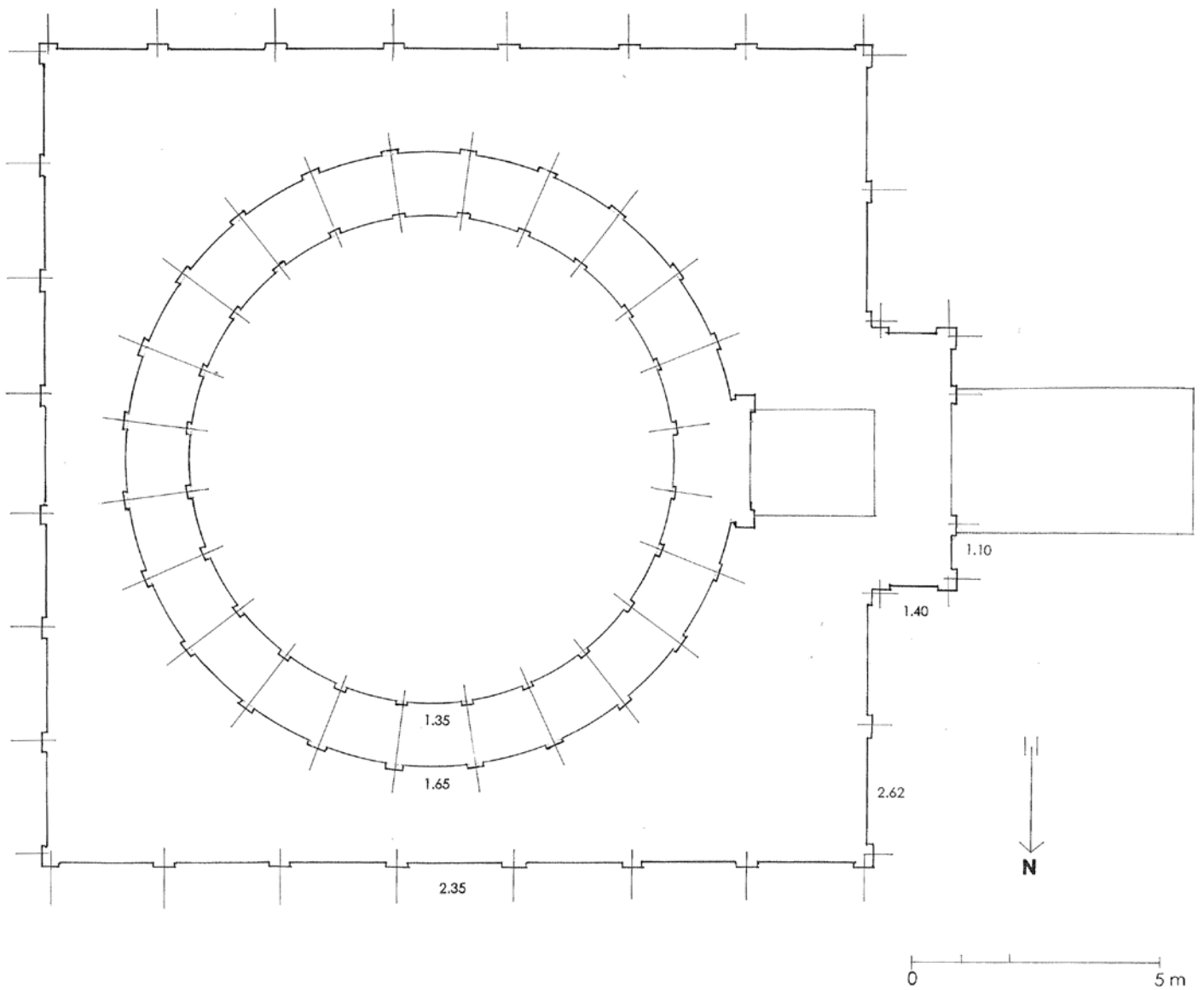

Fig. 261. Abbasahebchina, Stupa A. Plan showing the scheme of the pilasters axes.
(Martore 2003).

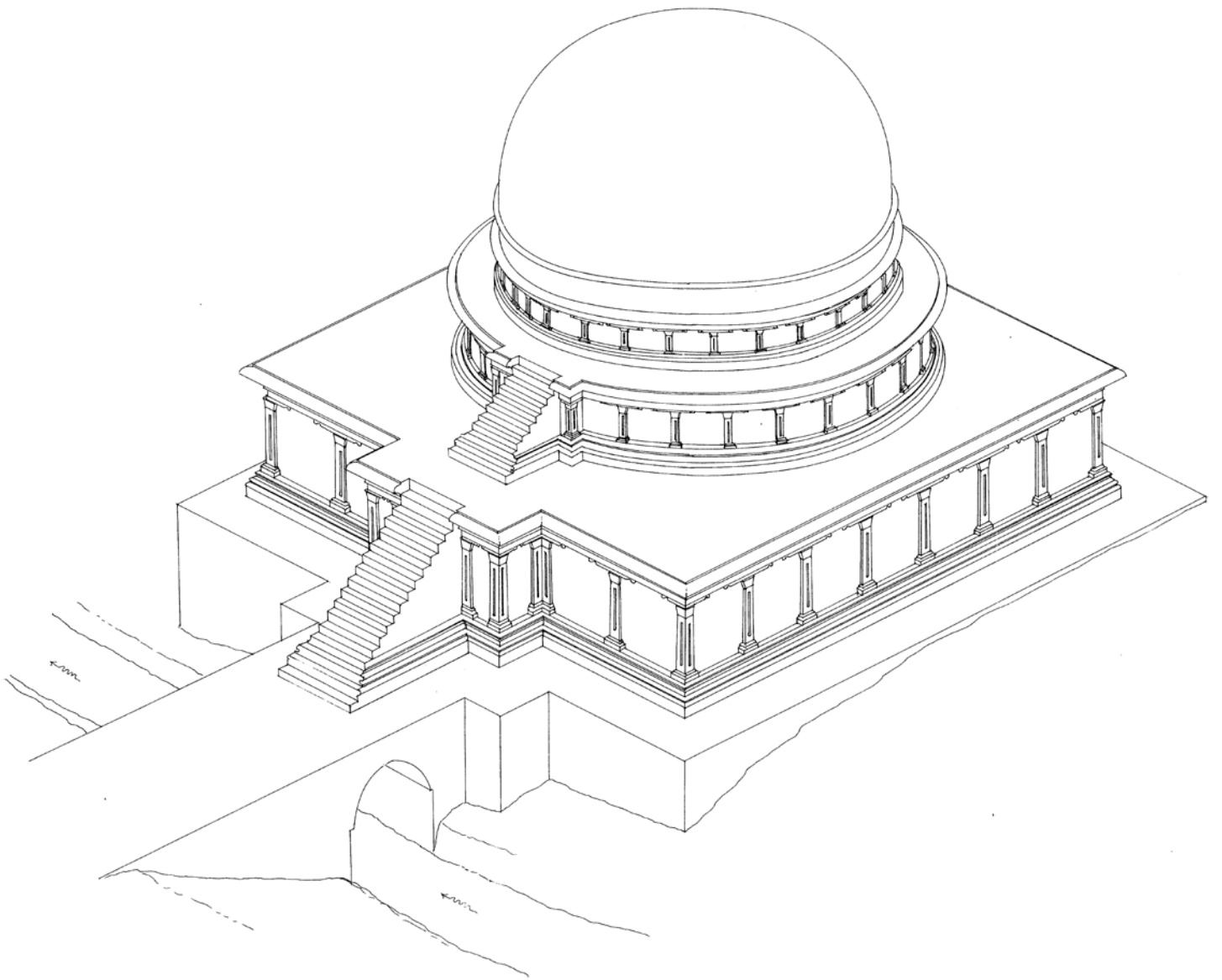

Fig. 262. Abbasahbchina, Stupa A. Axonometric view. (Martore 2003).



Fig. 263. Abbasahchina. Stupa B. N side. (Kuwayama 1993).

A. Stupas

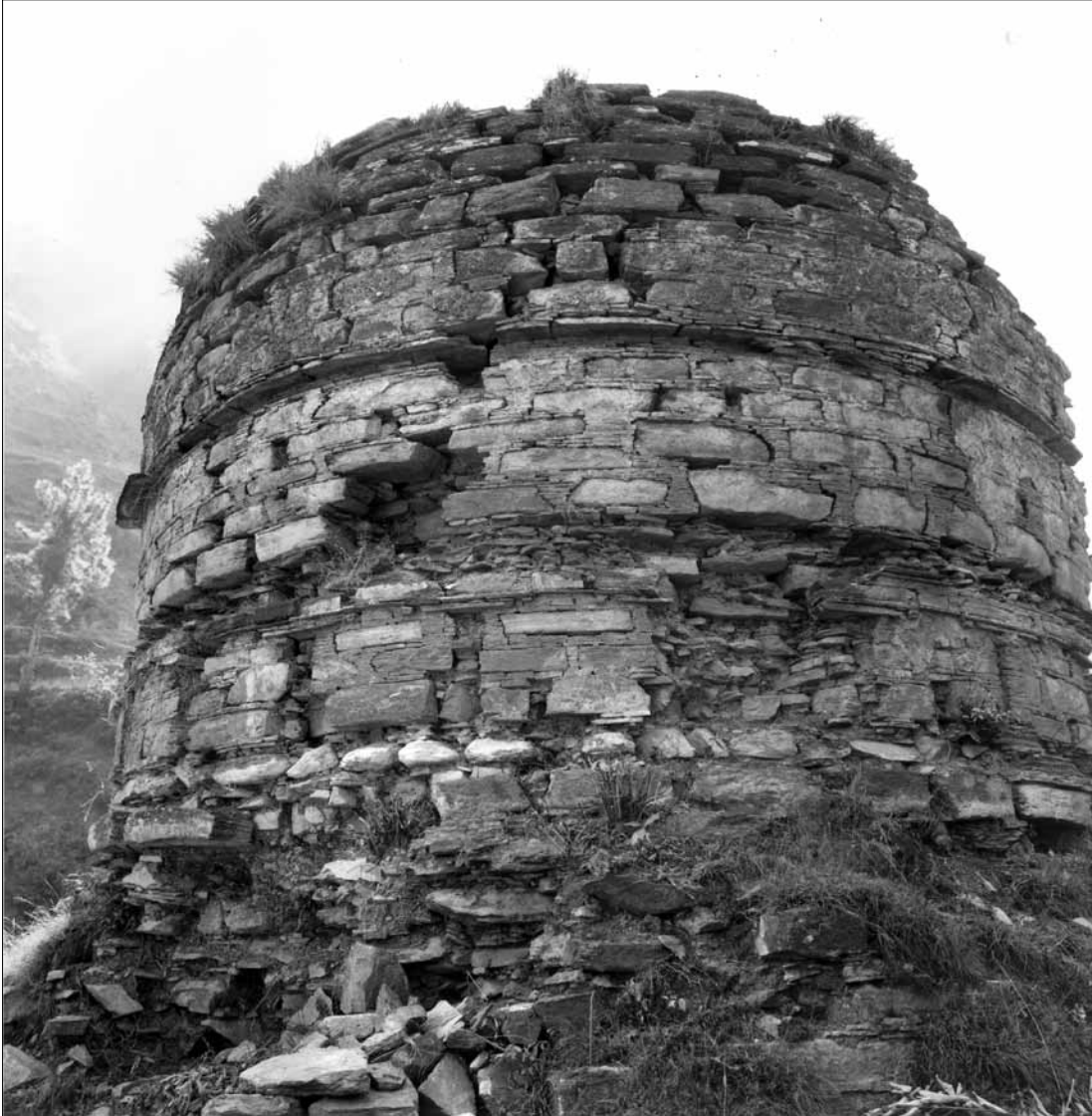

Fig. 264. Abbasahebchina. Stupa B. N side, 3rd storey (drum), 4th storey (transition storey of the composite dome) with socket for projecting slabs, 5th storey (raised dome). (Kuwayama 1993).

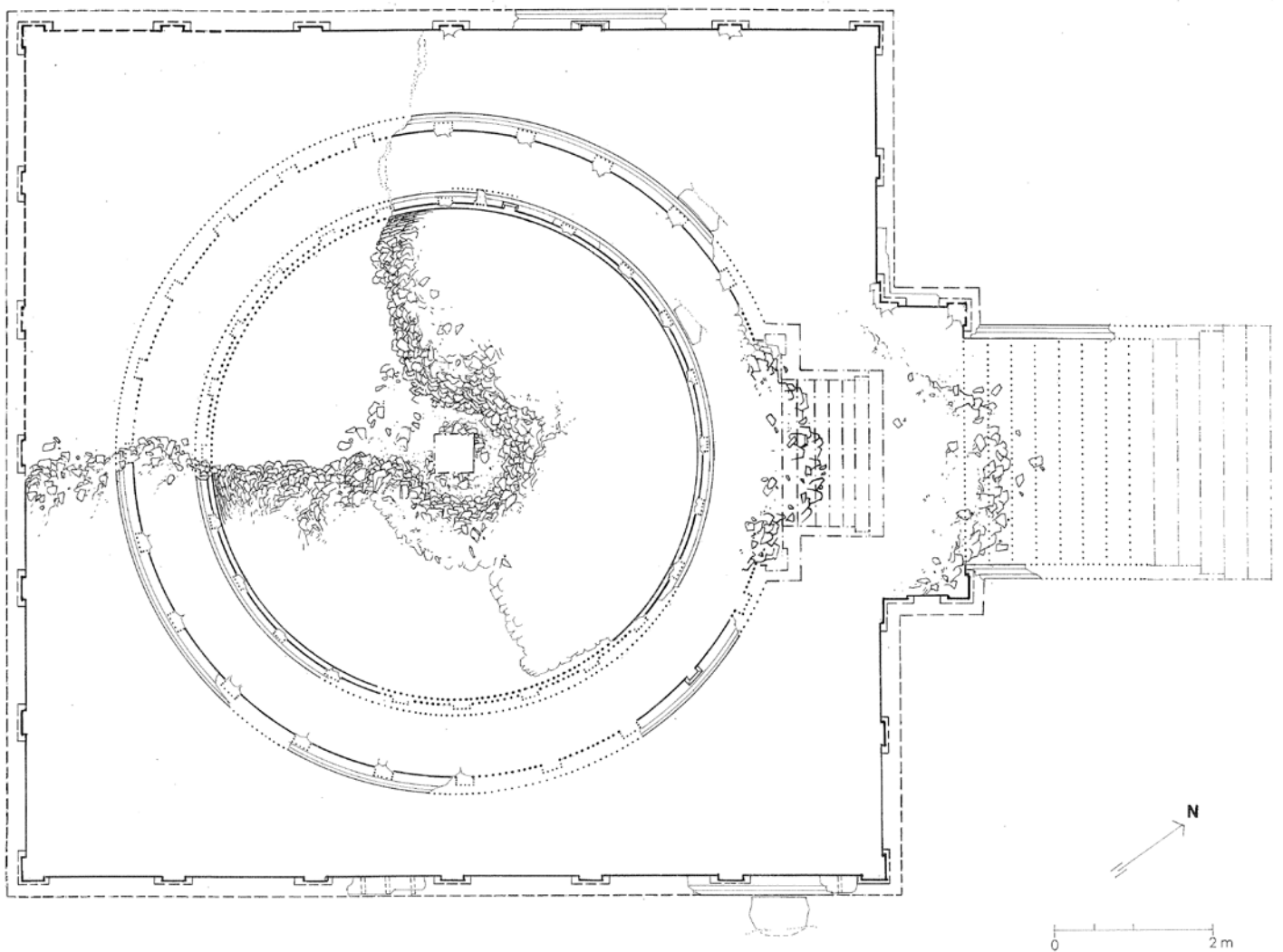

Fig. 265. Abbasahchina, Stupa B. Plan. (Sabelli 1993; Martore 2003).

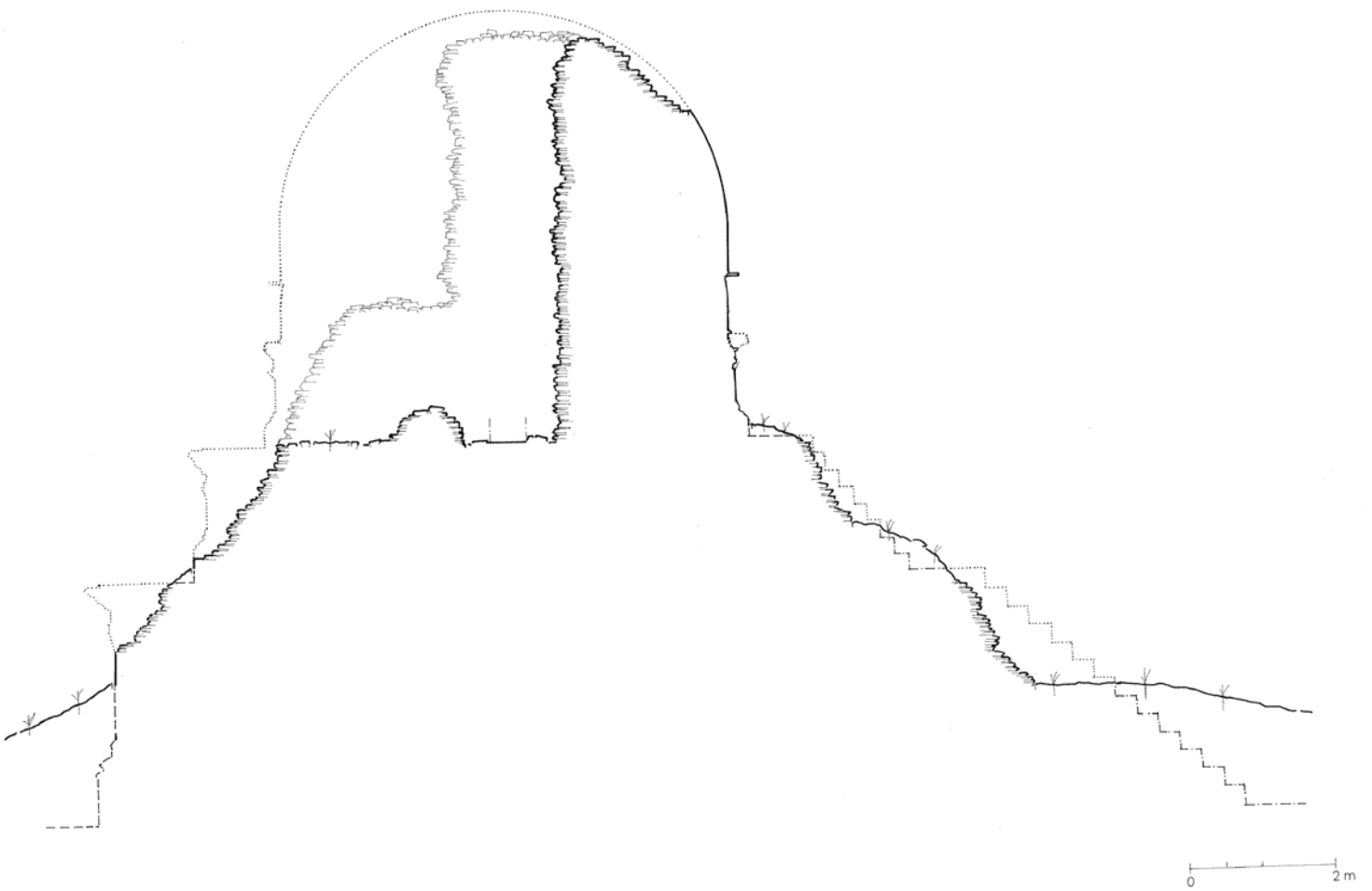

Fig. 266. Abbasahebchina, Stupa B. N-S cross section. (Sabelli 1993; Martore 2003).

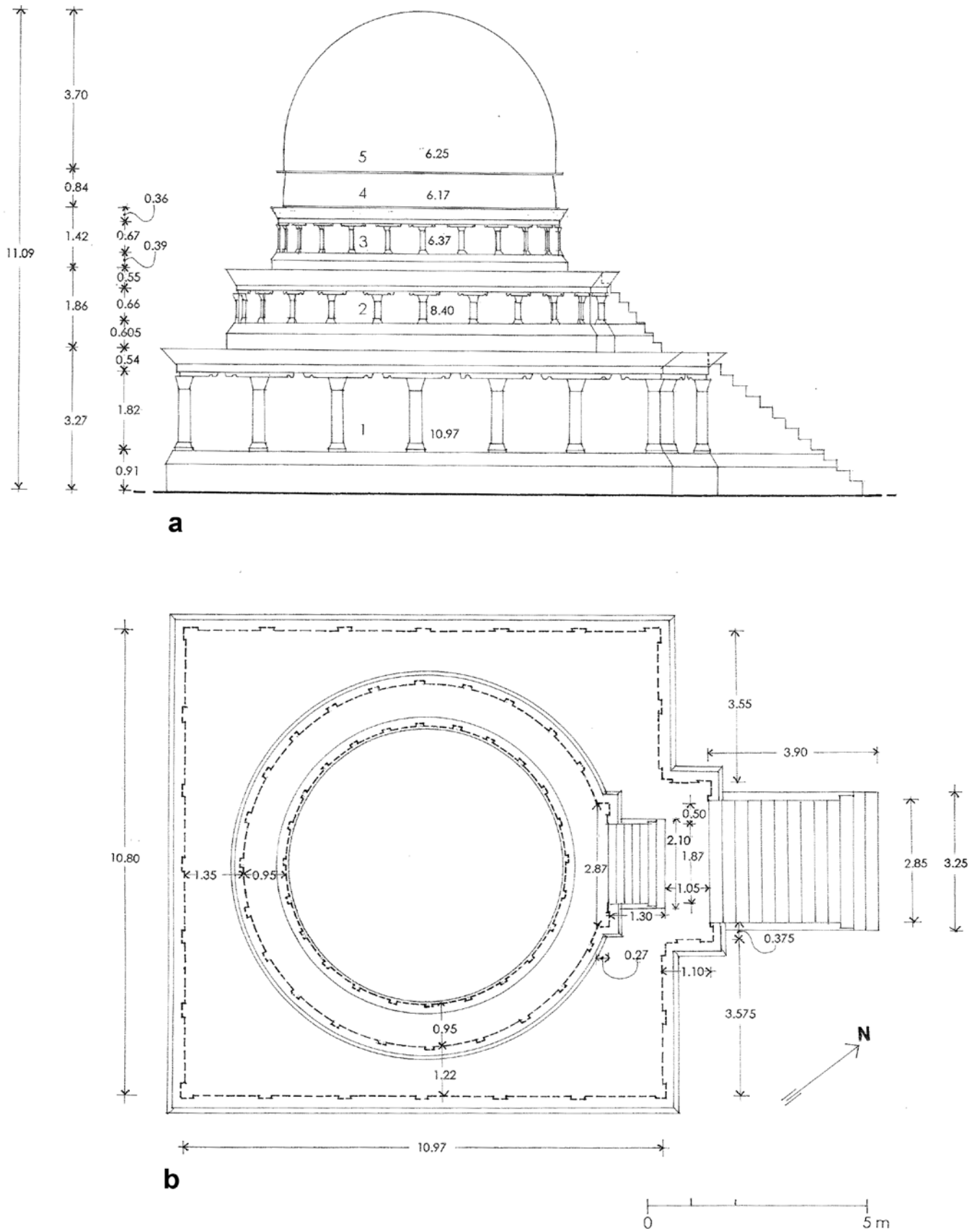

Fig. 267. Abbasahbchina, Stupa B. Elevation and sketch plan showing the measures. (Martore 2003).

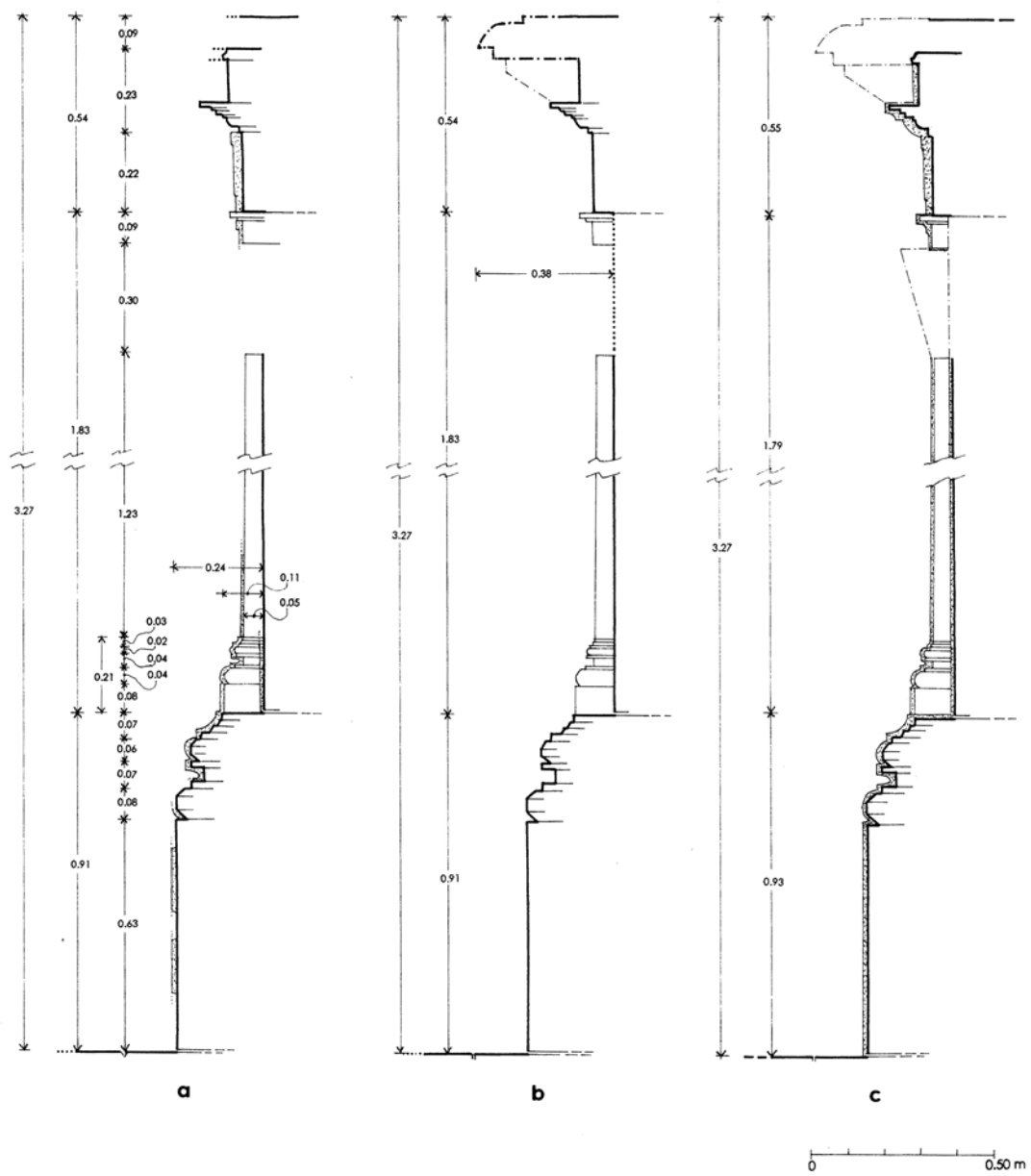

Fig. 268. Abbasahbchina, Stupa B. 1st storey. *a.* profile. *b.* reconstructed profile, without plaster. *c.* reconstructed profile, with plaster. (Sabelli 1993; Martore 2003).

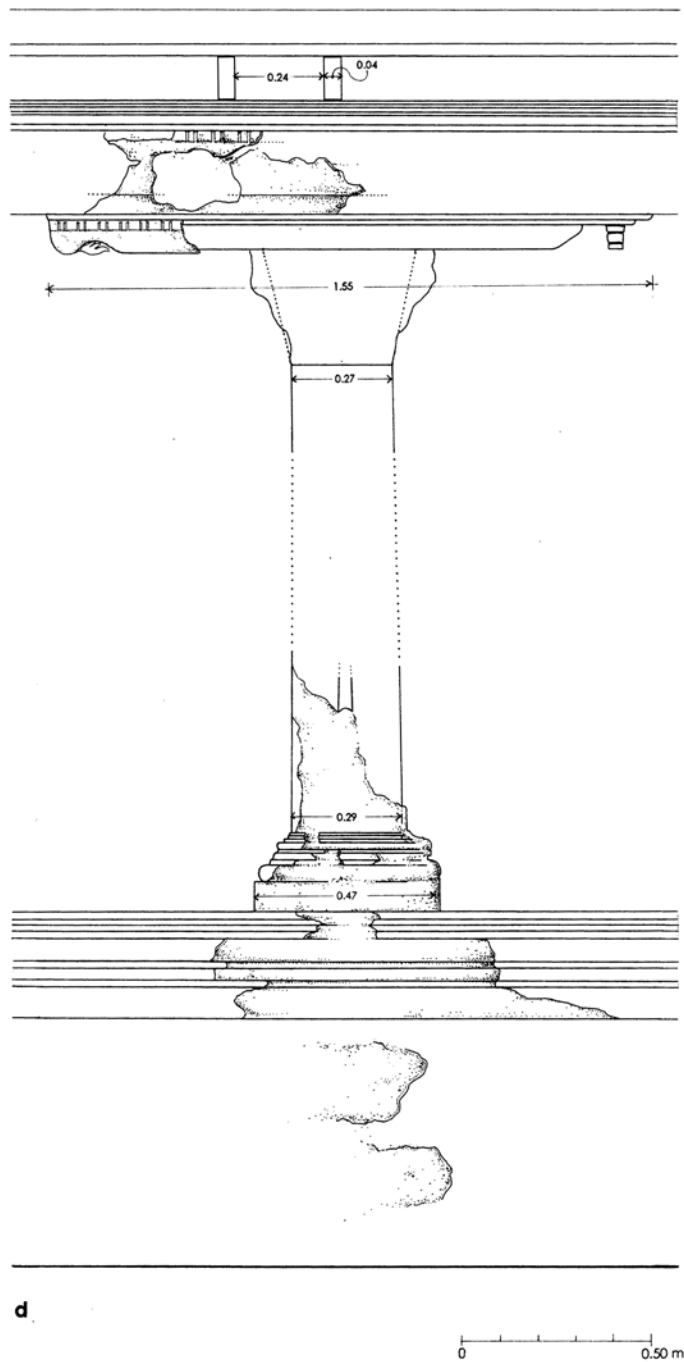

Fig. 269. Abbashehchina, Stupa B. 1st storey. *d.* elevation showing base, pilaster and cornice. (Sabelli 1993; Martore 2003).

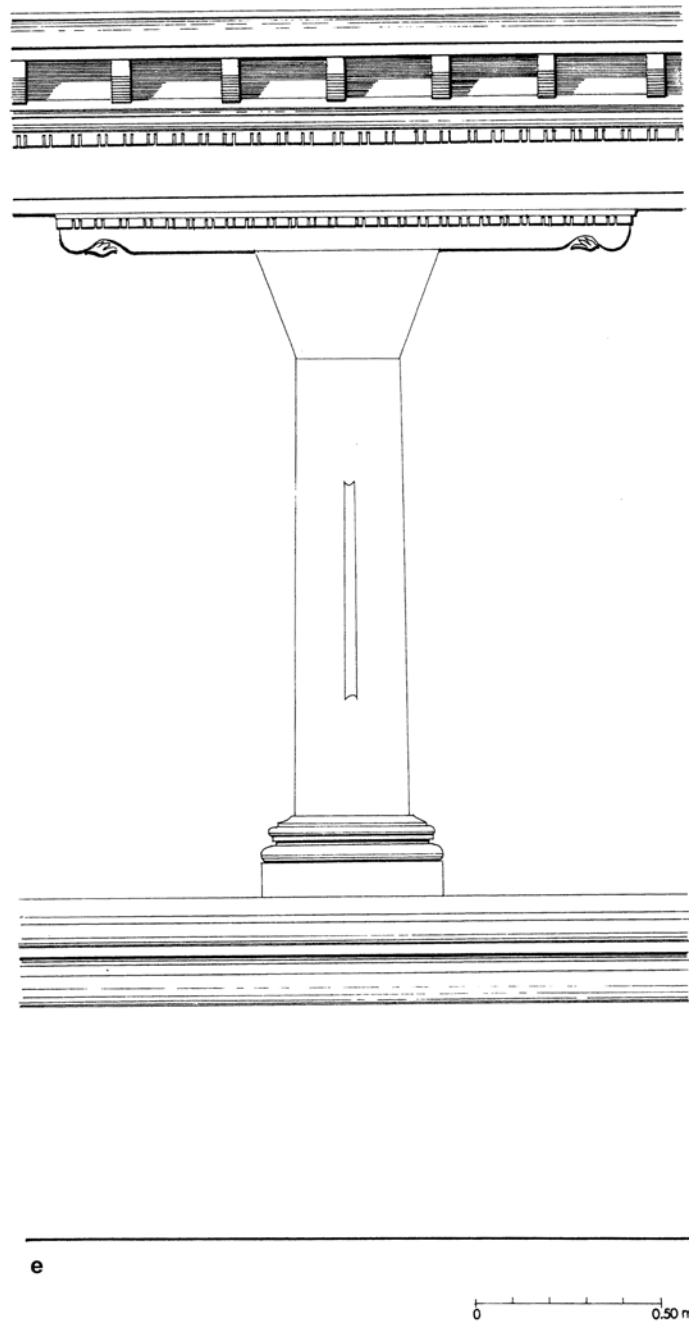

Fig. 270. Abbasahbchina, Stupa B. 1st storey. *e.* reconstructed elevation showing base, pilaster and cornice; reconstructed stuccowork. (Sabelli 1993; Martore 2003).

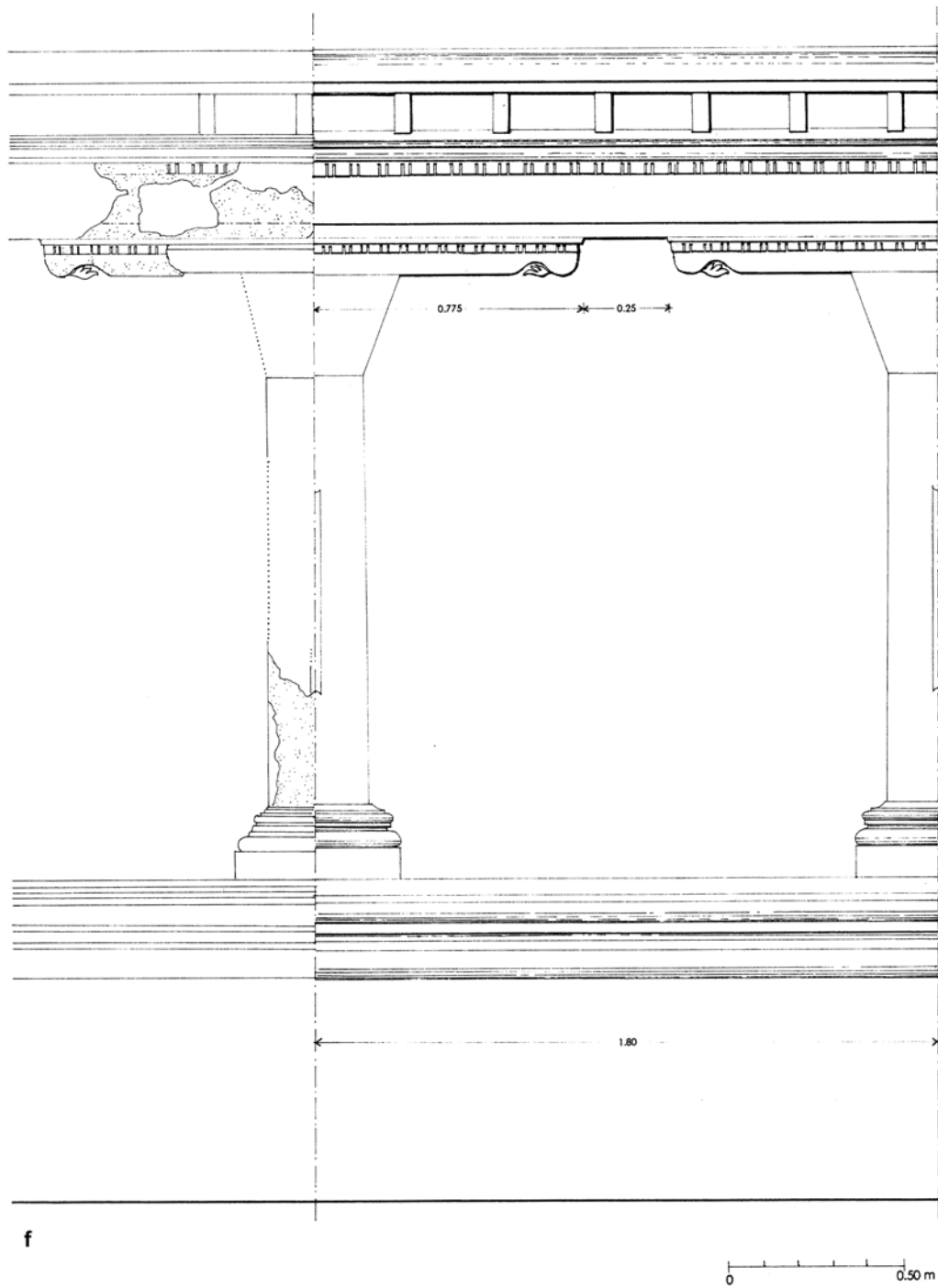

Fig. 271. Abbasahebchina, Stupa B. 1st storey. *f.* actual and reconstructed elevation showing base, interaxis between two pilasters and cornice; stuccowork. (Sabelli 1993; Martore 2003).

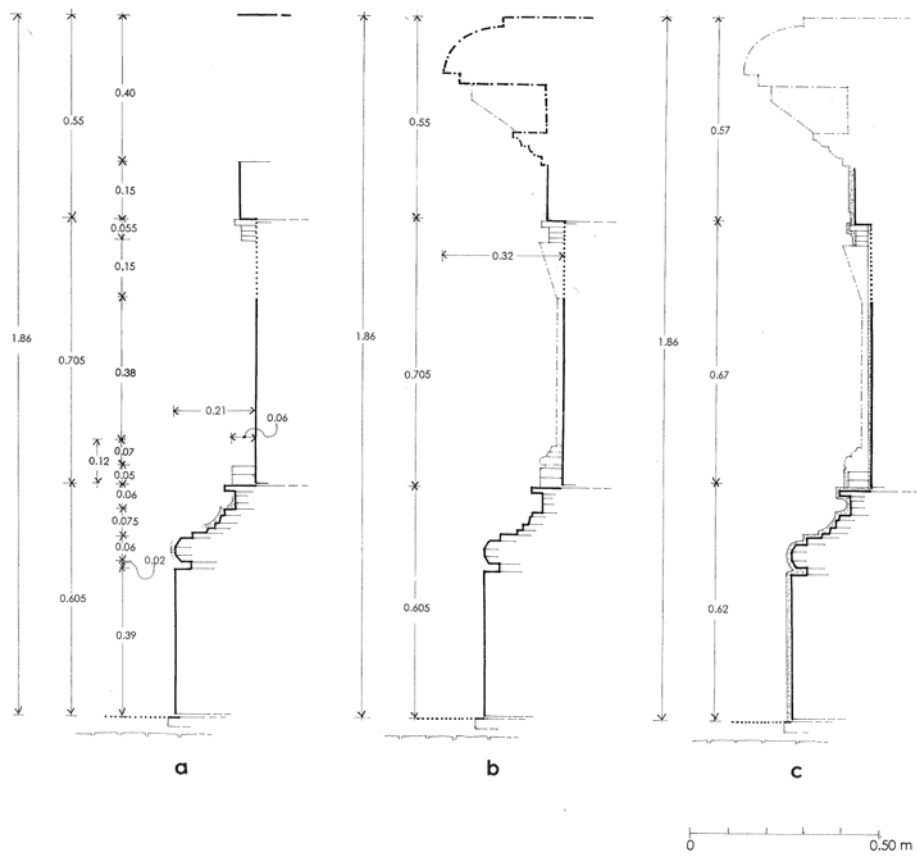

Fig. 272. Abbashehchina, Stupa B. 2nd storey. a. profile. b. reconstructed profile, without plaster. c. reconstructed profile, with plaster. (Sabelli 1993; Martore 2003).

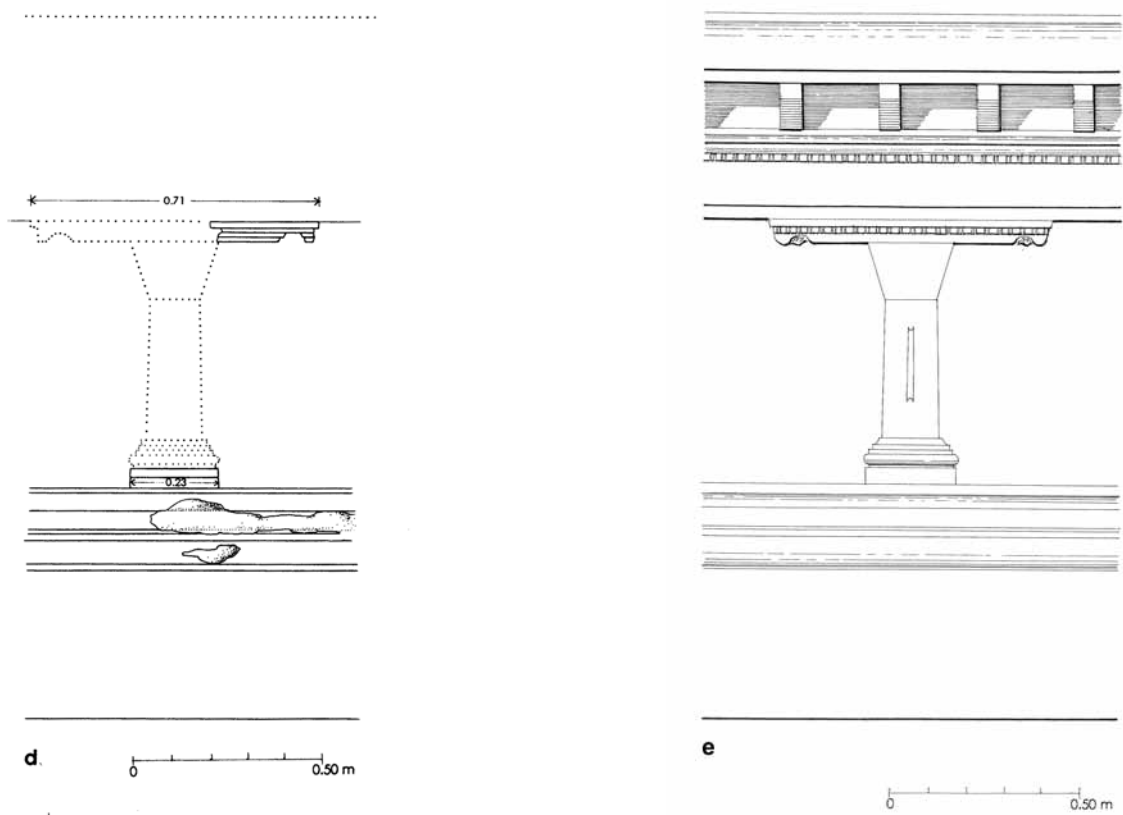

Fig. 273. Abbasahbchina, Stupa B. 2nd storey. *d.* elevation showing base, pilaster and cornice. *e.* reconstructed elevation showing base, pilaster and cornice; stuccowork. (Sabelli 1993; Martore 2003).

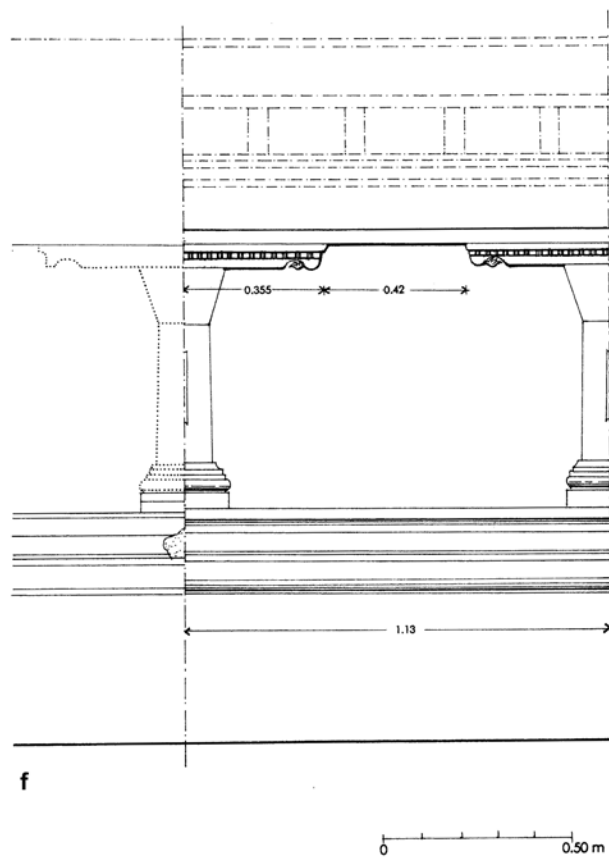

Fig. 274. Abbasahebchina, Stupa B. 2nd storey. *f.* actual and reconstructed elevation showing base, interaxis between two pilasters and cornice; stuccowork. (Sabelli 1993; Martore 2003).

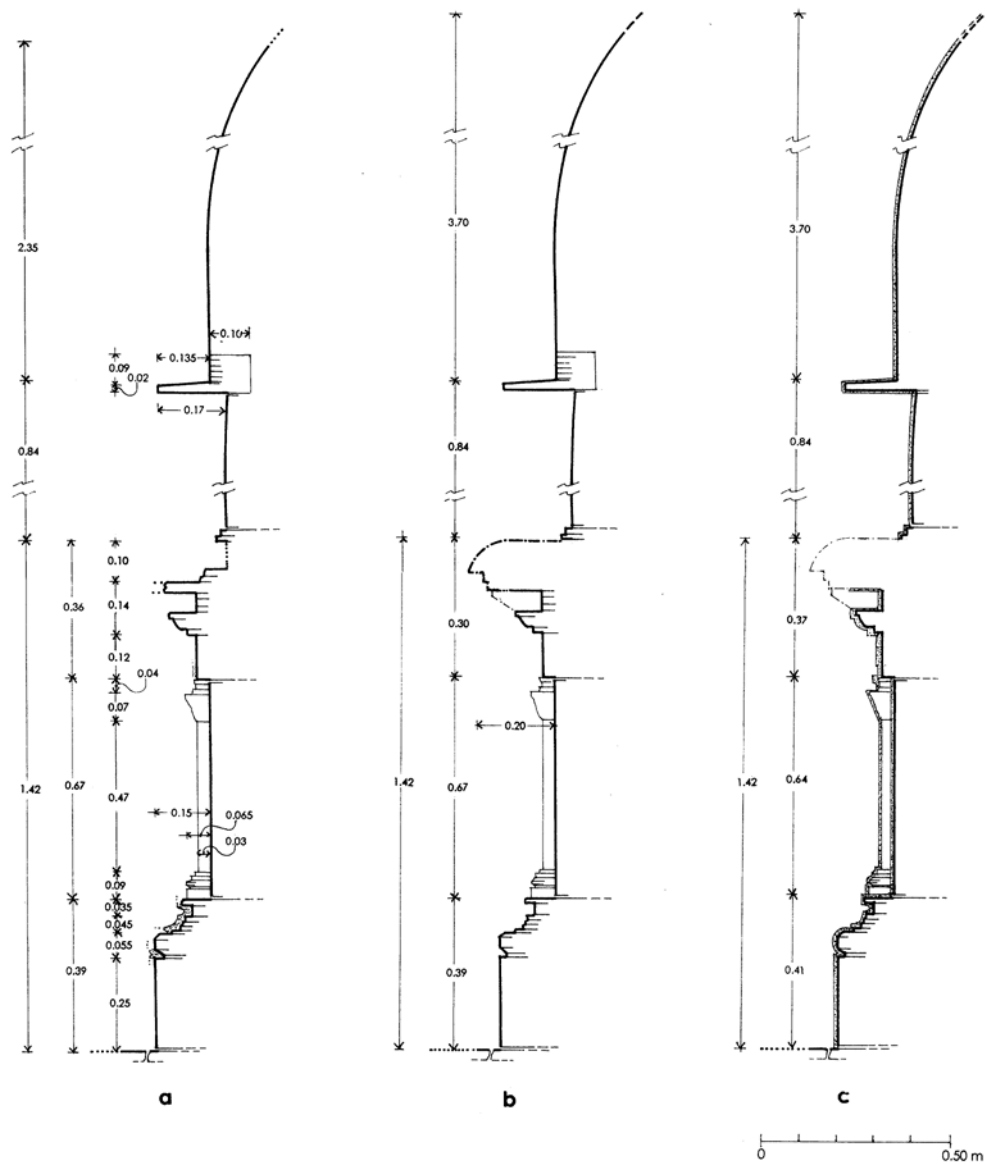

Fig. 275. Abbasahebchina, Stupa B. 3rd storey (drum), 4th storey (transition storey of the composite dome), 5th storey (raised dome). *a.* profile. *b.* reconstructed profile, without plaster. *c.* reconstructed profile, with plaster. (Sabelli 1993; Martore 2003).

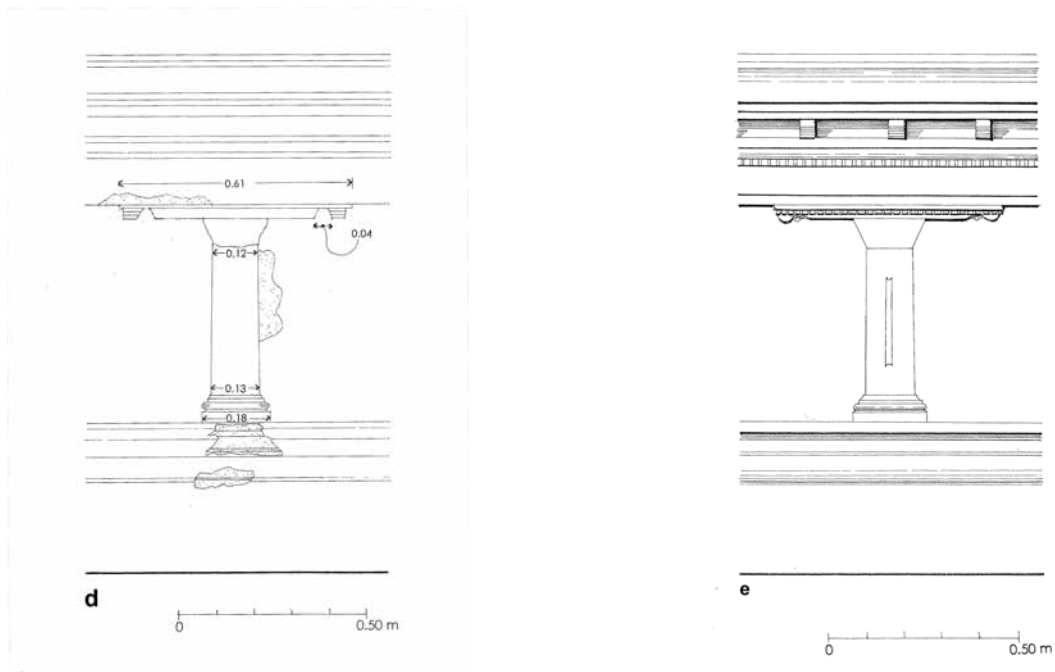

Fig. 276. Abbasahebchina, Stupa B. 3rd storey (drum). *d.* elevation showing base, pilaster and cornice; traces of plaster. *e.* reconstructed elevation showing base, pilaster and cornice; stuccowork. (Sabelli 1993; Martore 2003).

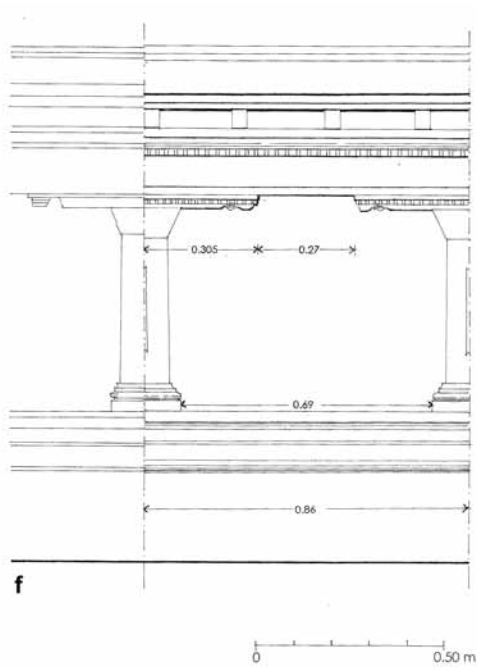

Fig. 277. Abbasahabchina, Stupa B. 3rd storey (drum). *f.* actual and reconstructed elevation showing base, interaxis between two pilasters and cornice; stuccowork. (Sabelli 1993; Martore 2003).

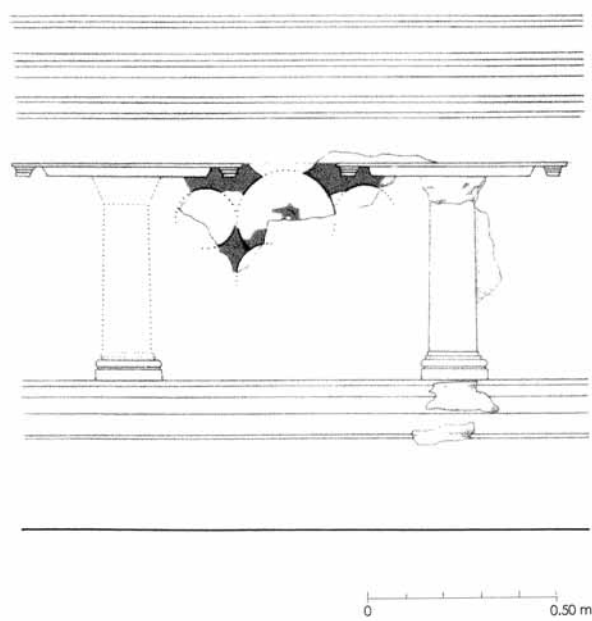

Fig. 278. Abbasahabchina, Stupa B. 3rd storey (drum). W side; remains of painting (probably Buddha sided by two figures with nimbus) in the field between two pilasters. (Sabelli 1993).

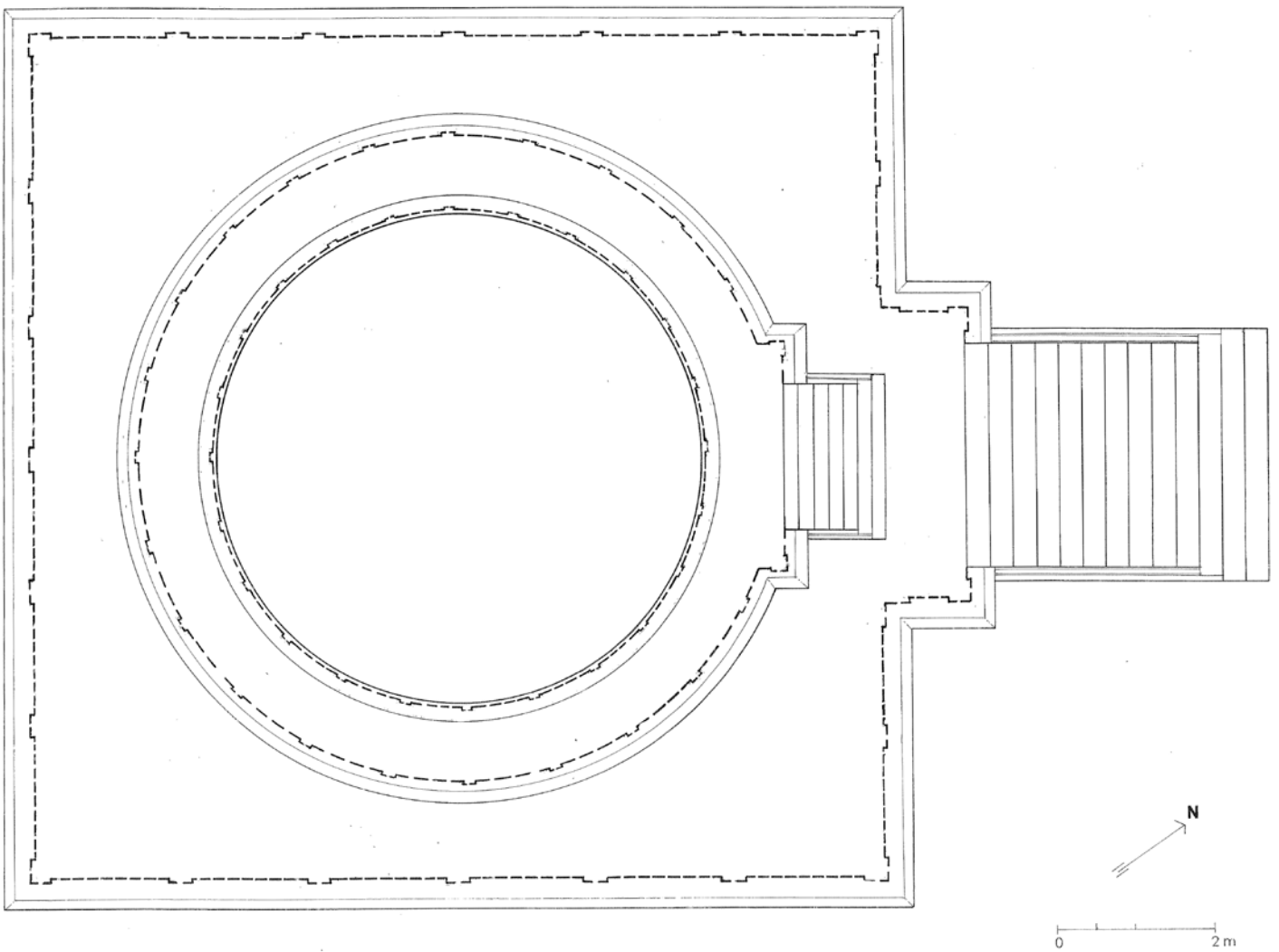

Fig. 279. Abbasahebchina, Stupa B. Reconstructed plan. (Sabelli 1993).

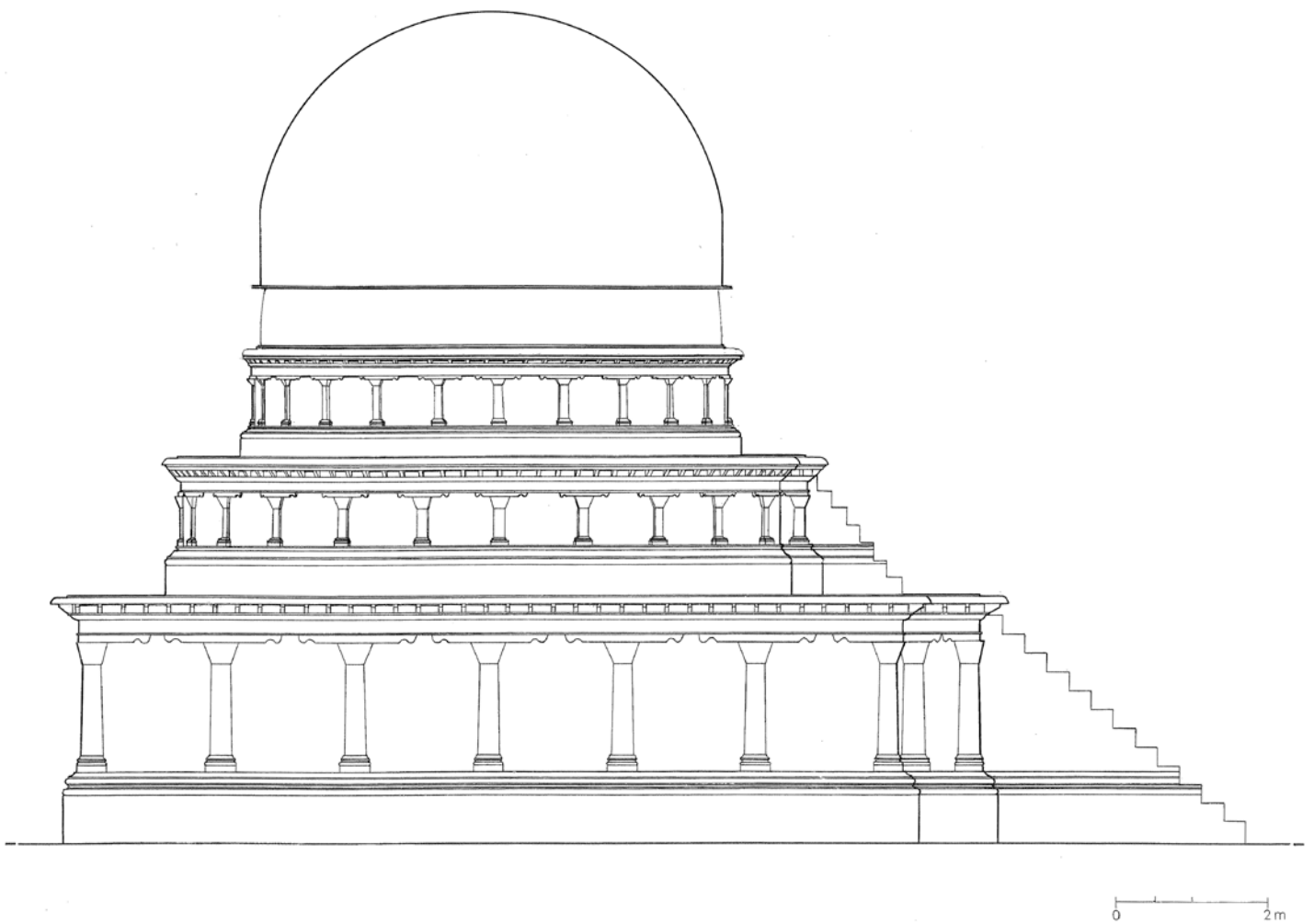

Fig. 280. Abbasahbchina, Stupa B. Reconstructed elevation. (Sabelli 1993).

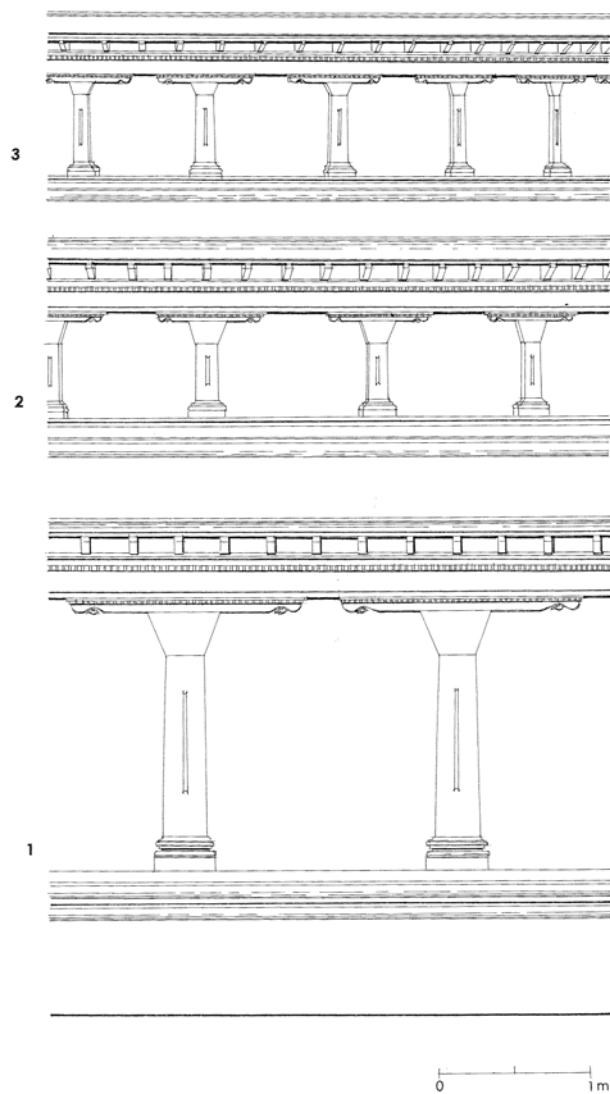

Fig. 281. Abbasahebchina, Stupa B. Reconstruction of a stretch of the 1st, 2nd, 3rd storeys. (Sabelli 1993; Martore 2003).

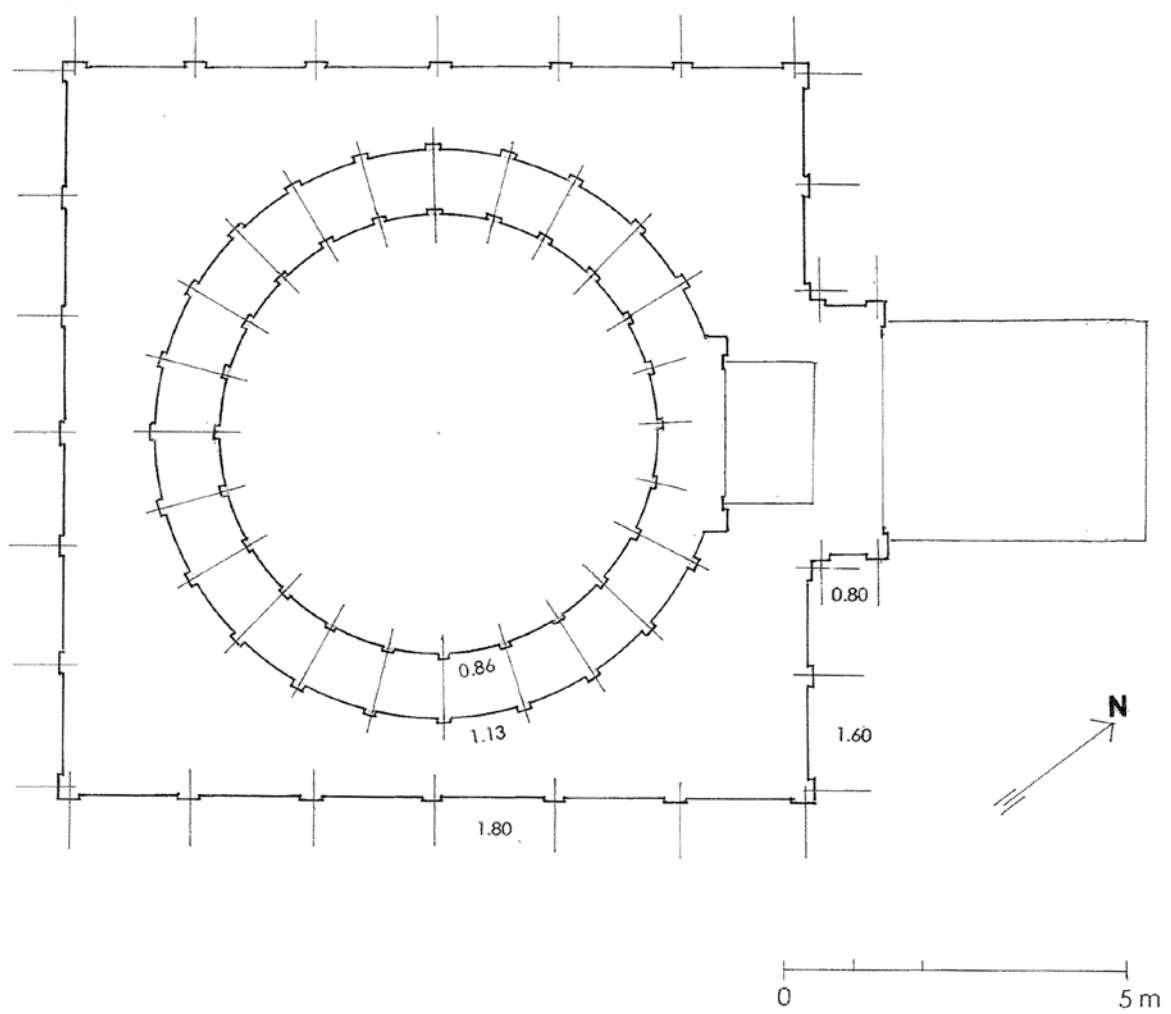

Fig. 282. Abbasahbchina, Stupa B. Plan showing the scheme of the pilasters axes. (Martore 2003).

A. Stupas

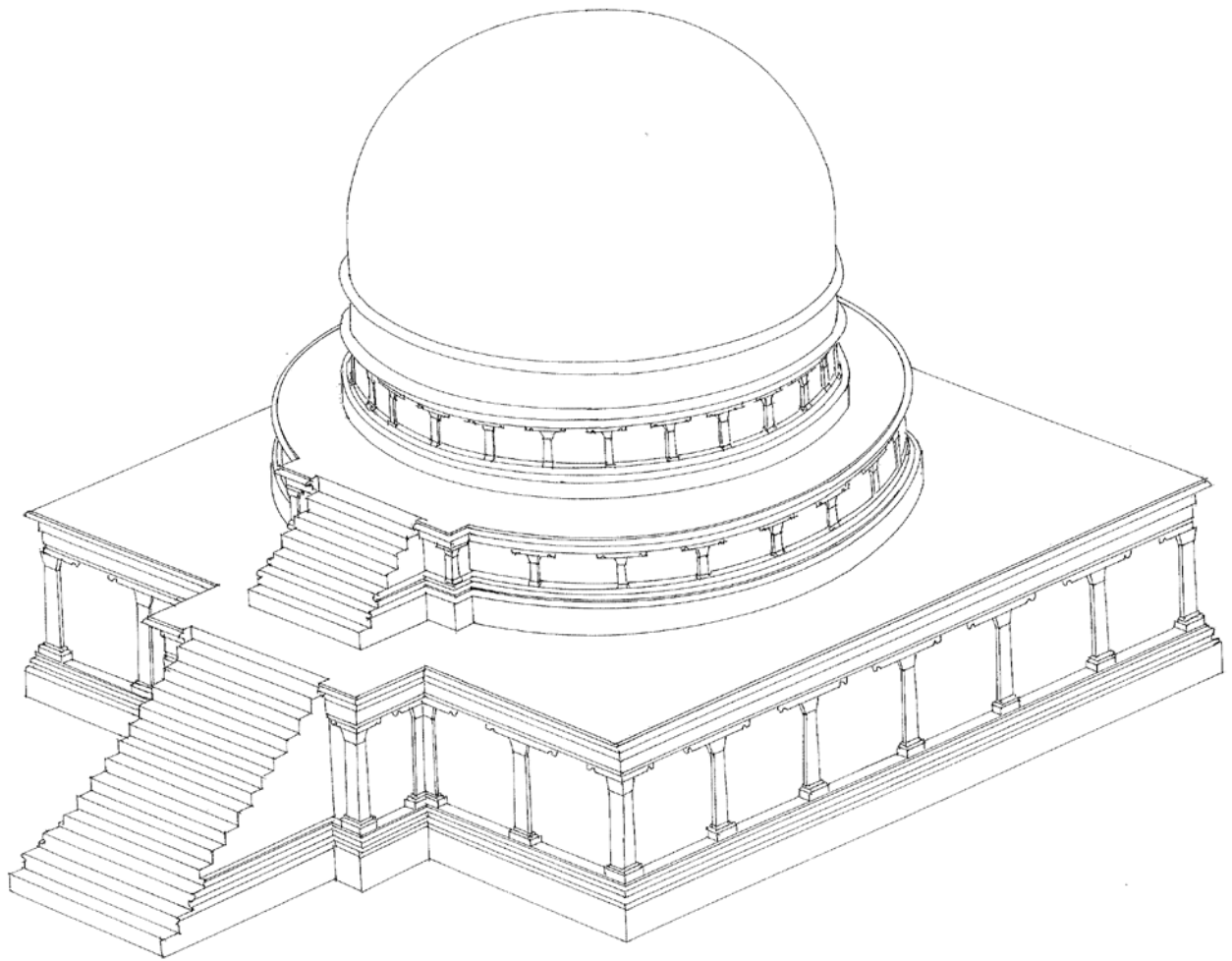

Fig. 283. Abbasahebchina, Stupa B. Axonometric view. (Martore 2003).



Fig. 284. Abbashehchina. Stupa C with monuments (vihara D, F) on the left and substruction structure. (After Behrendt 2004: fig. 111).

A. Stupas

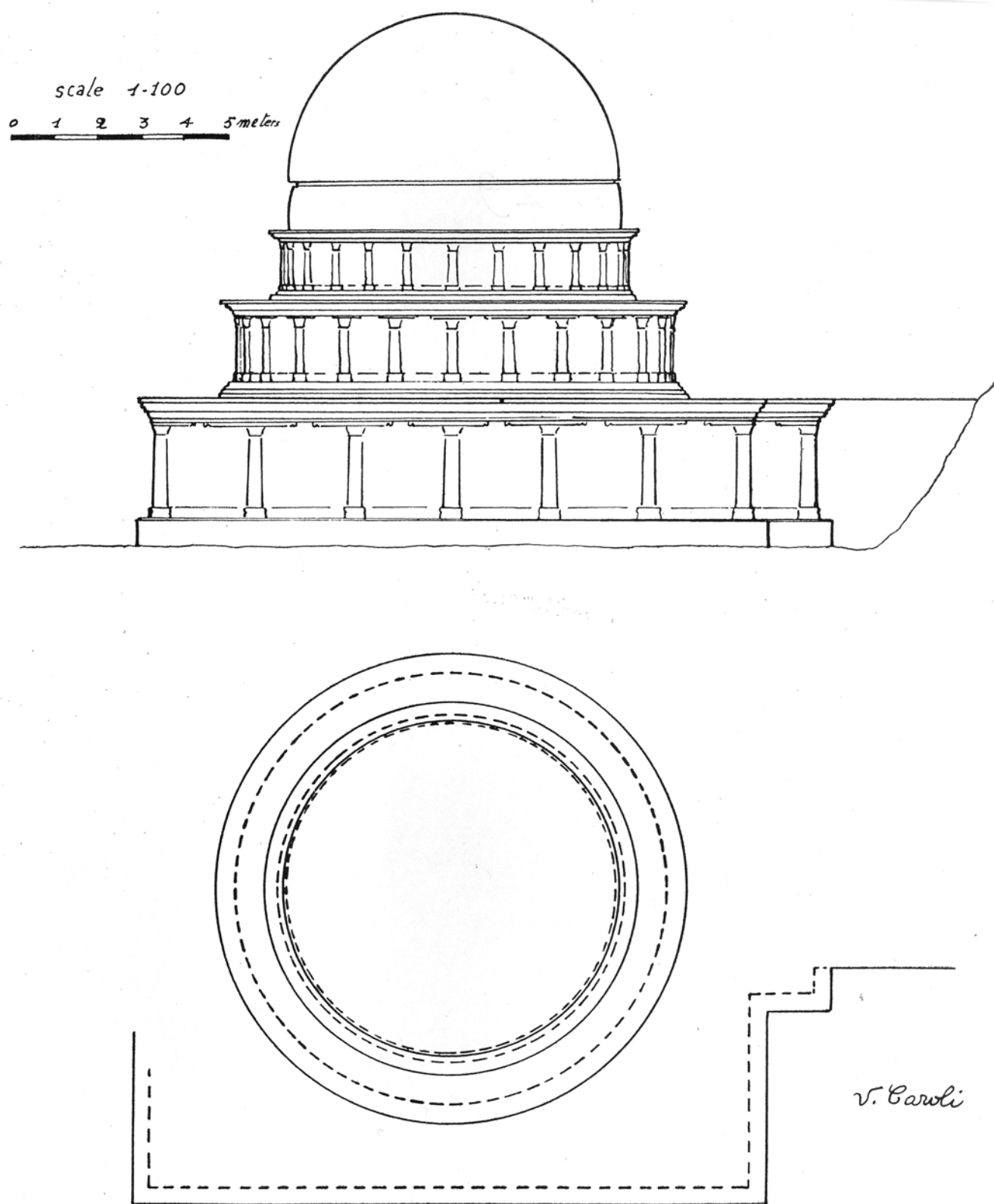

Fig. 285. Abbasahebchina. Stupa C. Elevation and plan. (After Tucci 1958: fig. 32; drawing by Cairoli).



Fig. 286. Abbasahchina. Stupa C. E side. (Spagnesi 2005).



Fig. 287. Abbasahchina. Stupa C. E side, 1st storey, N stretch; with plaster remains. (Spagnesi 2005).



Fig. 288. Abbasahebchina. Stupa C. E side, 1st storey, N stretch; detail of plaster remains. (Spagnesi 2005).



Fig. 289. Abbasahbchina. Stupa C. N side with stairway projection and inner corner pilaster. (Kuwayama 1993).



Fig. 290. Abbasahebchina. Stupa C. E side, 1st storey. (Kuwayama 1993).



Fig. 291. Abbasahbchina. Stupa C. General view on the SE corner. (Kuwayama 1993).

A. Stupas



Fig. 292. Abbasahebchina. Stupa C. E side, 3rd, 4th and 5th storey. (Kuwayama 1993).



Fig. 293. Abbasahchina. Stupa C. S side, 3rd, 4th and 5th storey; plaster remains.
(Kuwayama 1993).



Fig. 294. Abbasahebchina. Stupa C. S side, 3rd storey; plaster remains. (Kuwayama 1993).



Fig. 295. Abbashehchina. Stupa C. E side, 3rd storey; plaster remains. (Kuwayama 1993).

A. Stupas

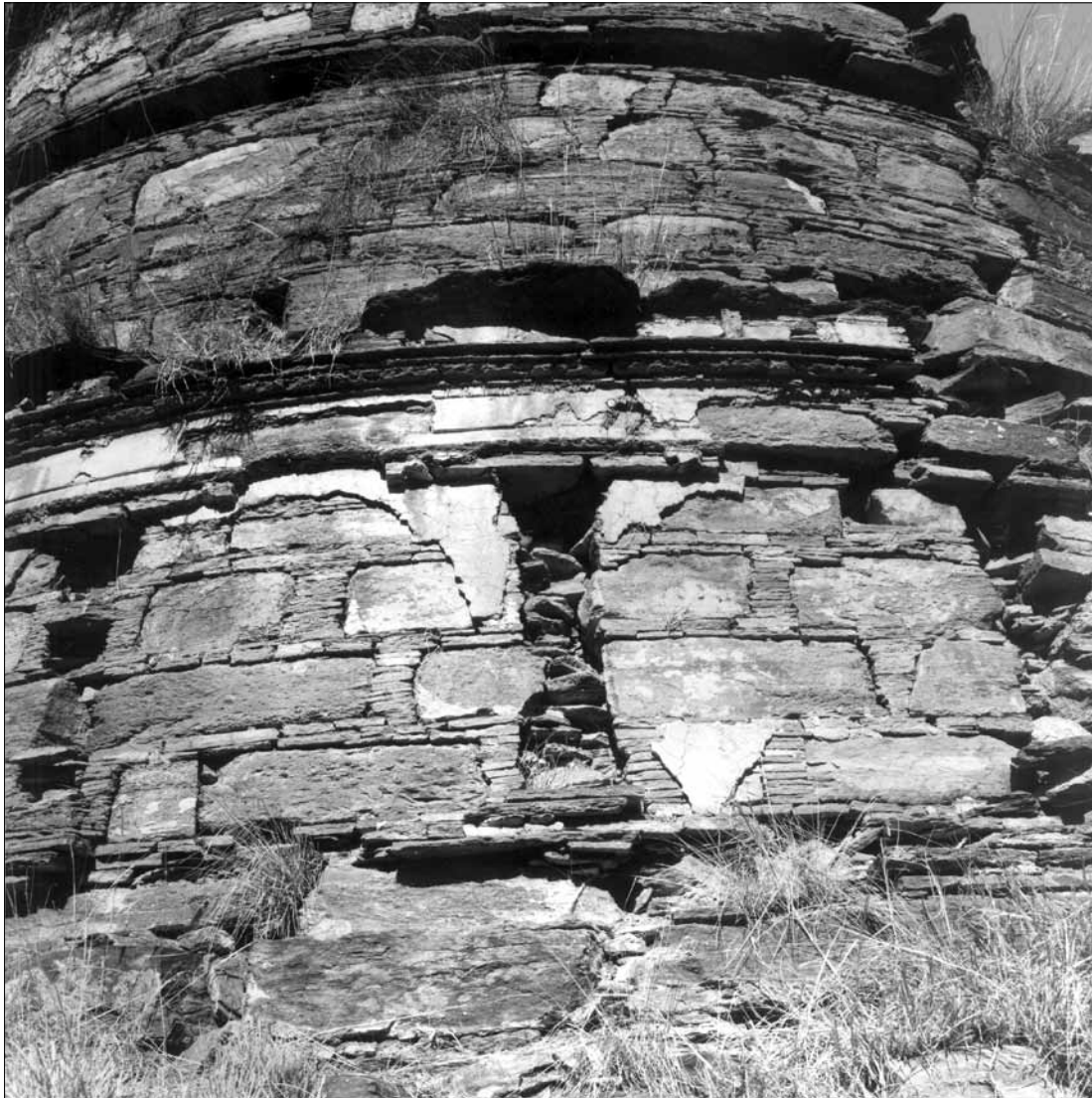

Fig. 296. Abbasahebchina. Stupa C. E side, 3rd and 4th storey; plaster remains. (Kuwayama 1993).



Fig. 297. Abbashehchina. Stupa C. E side, 3rd, 4th and 5th storey with socket lacking projecting slabs; profile. (Taddei 1957).

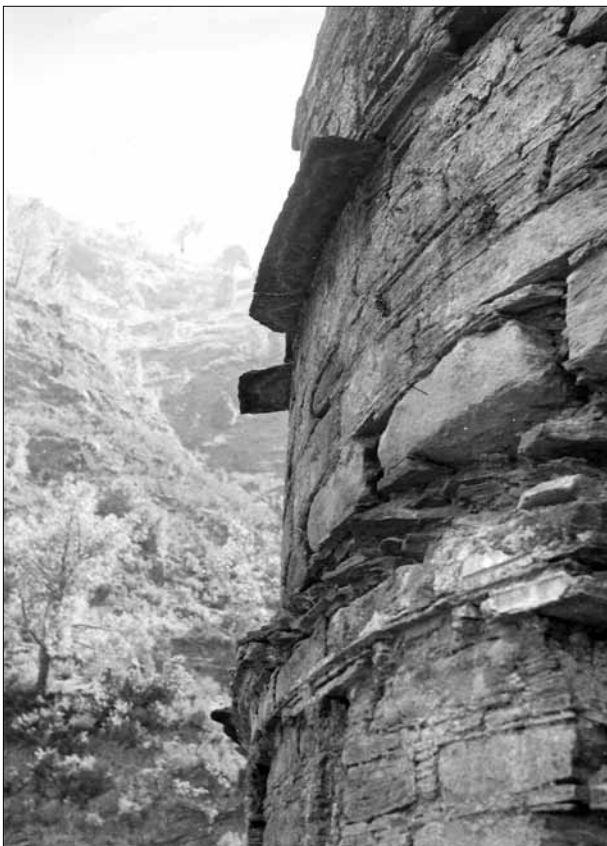

Fig. 298. Abbashehchina. Stupa C. E side, 3rd, 4th and 5th storey with socket with projecting slabs; profile. (Taddei 1957; Neg. CS).

A. Stupas



Fig. 299.
Abbasahebchina.
Stupa C. E side,
4th and 5th storey
with socket with
projecting slabs.
(Taddei 1957; Neg.
CS).

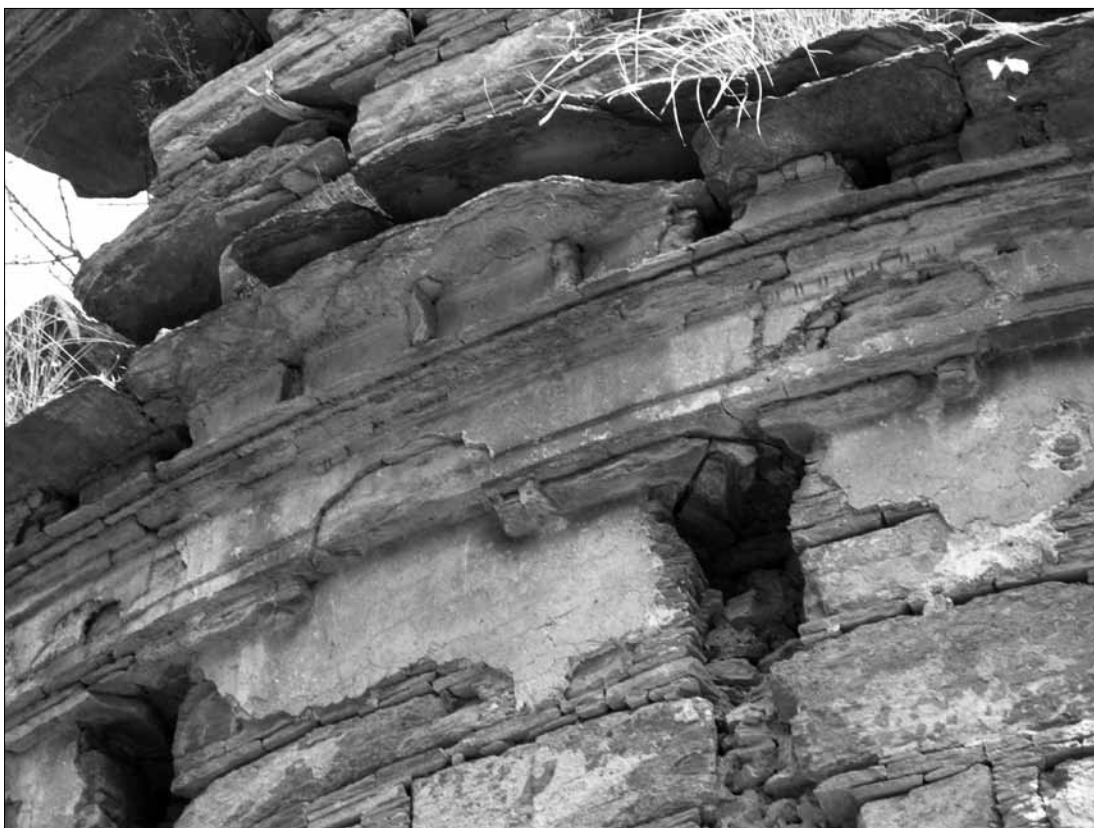

Fig. 300. Abbasahebchina. Stupa C. SE side, 3rd storey; modillions of pilasters, stretch of architraved and bracketed cornice; plaster remains. Detail. (Spagnesi 2005).



Fig. 301. Abbashehchina. Stupa C. SE side, 3rd storey; modillions of pilasters, stretch of architraved and bracketed cornice; plaster remains. (Spagnesi 2005).



Fig. 302. Abbashehchina. Stupa C. SE side, 3rd storey; modillions of pilasters, stretch of architraved and bracketed cornice; plaster remains. (Spagnesi 2005).



Fig. 303. Abbasahbchina. Stupa C. SE side, 3rd storey; modillions of pilasters, stretch of architraved and bracketed cornice; plaster remains. (Spagnesi 2005).



Fig. 304. Abbasahbchina. Stupa C, SE side, 3rd storey; modillions of pilasters, stretch of architraved and bracketed cornice; plaster remains. (Spagnesi 2005).

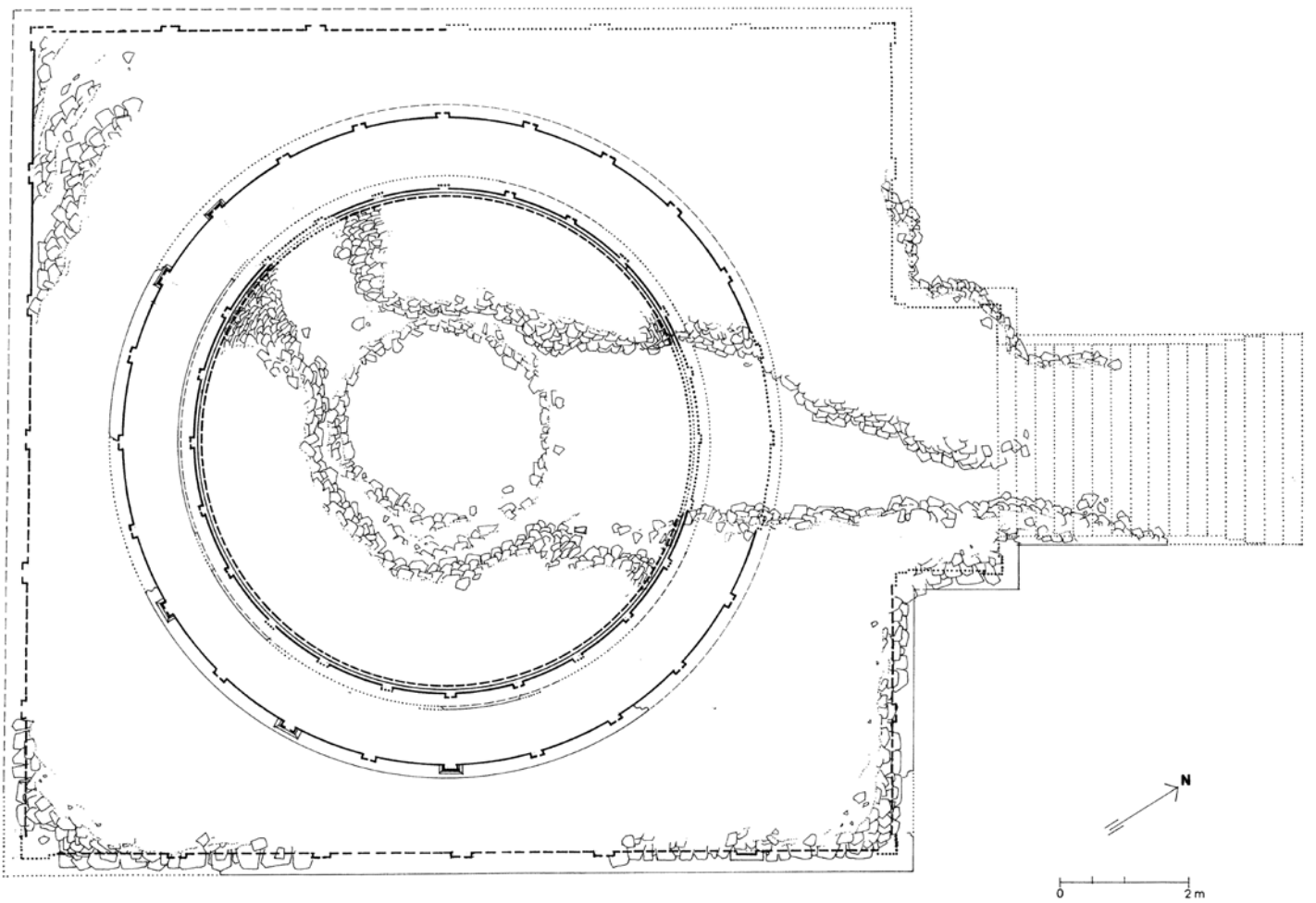

Fig. 305. Abbasahchina, Stupa C. Plan. (Sabelli 1993; Martore 2003).

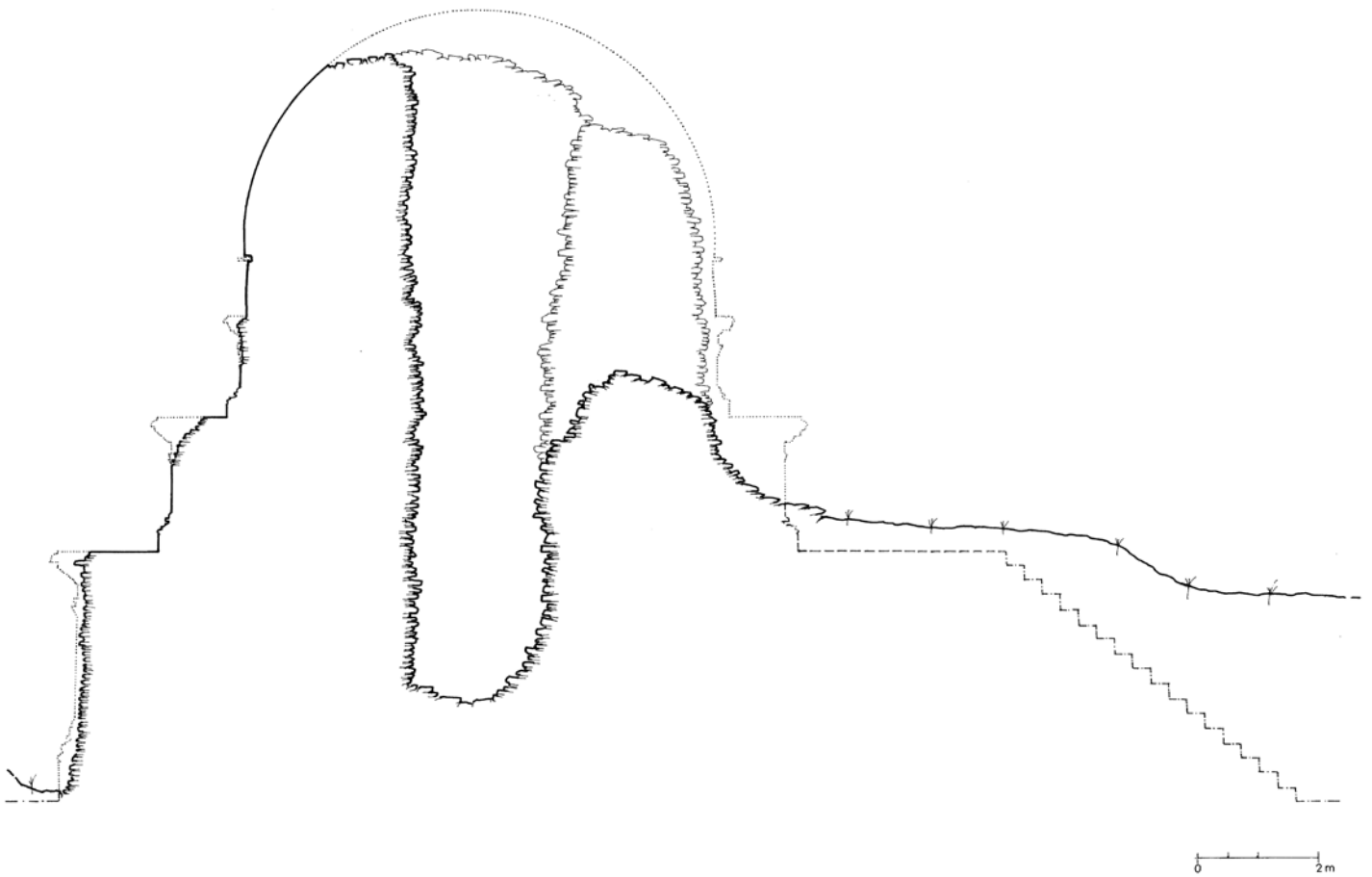

Fig. 306. Abbasahebchina, Stupa C. N-S cross section. (Sabelli 1993; Martore 2003).

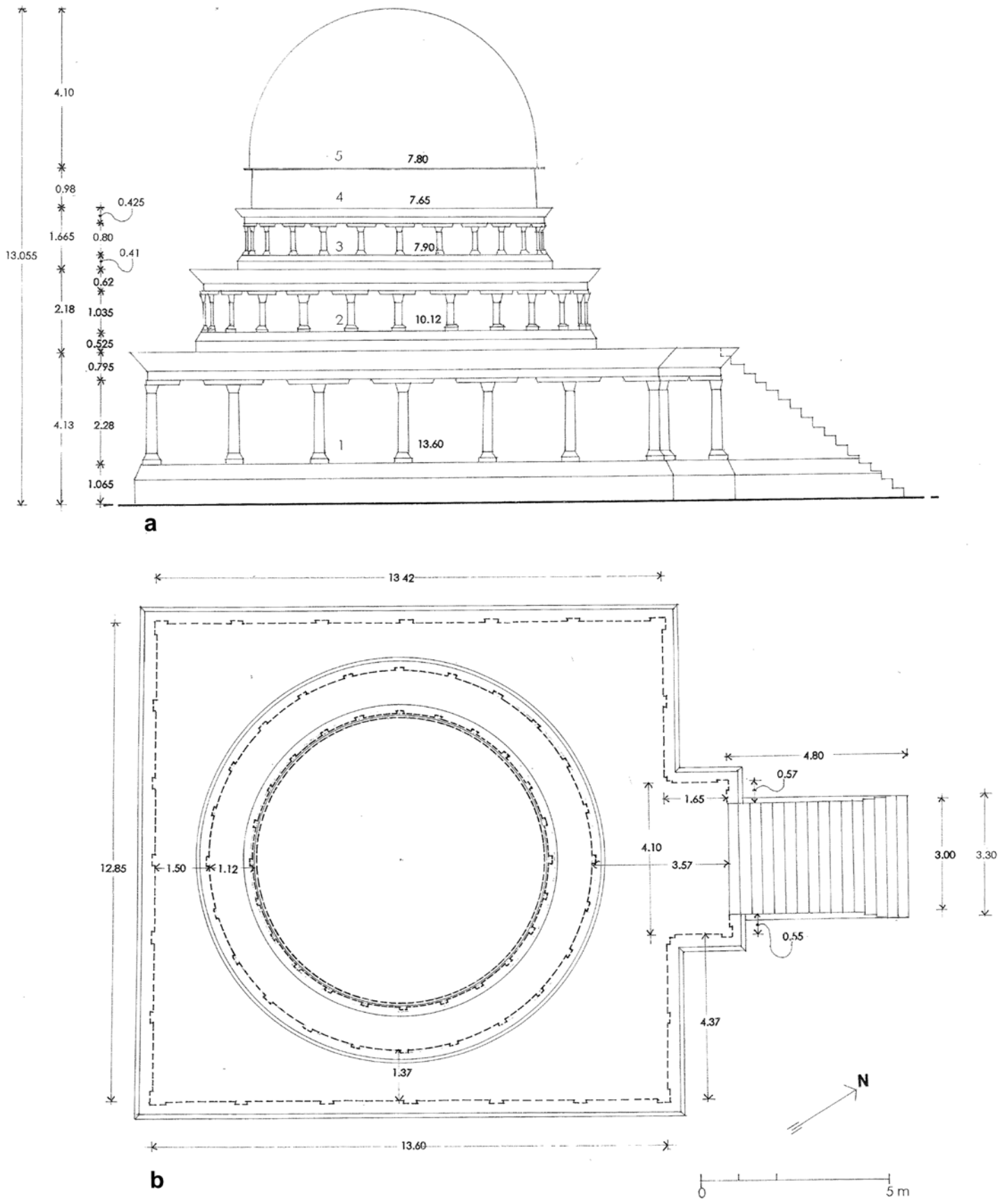

Fig. 307. Abbasahebchina, Stupa C. a, b. sketch plan and elevation showing the measures. (Martore 2003).

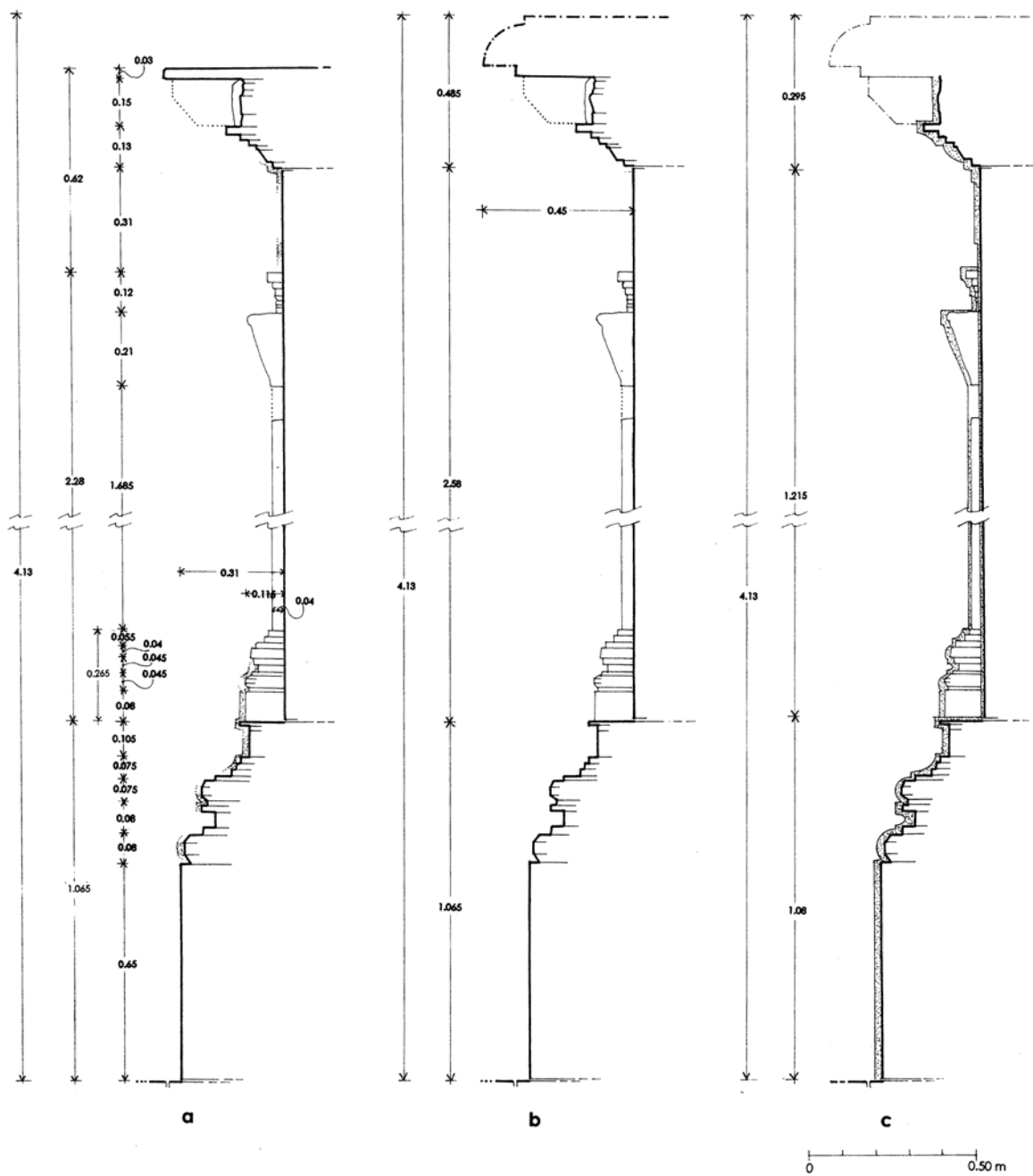

Fig. 308. Abbasahebchina, Stupa C. 1st storey. *a.* profile. *b.* reconstructed profile, without plaster. *c.* reconstructed profile, with plaster. (Sabelli 1993; Martore 2003).

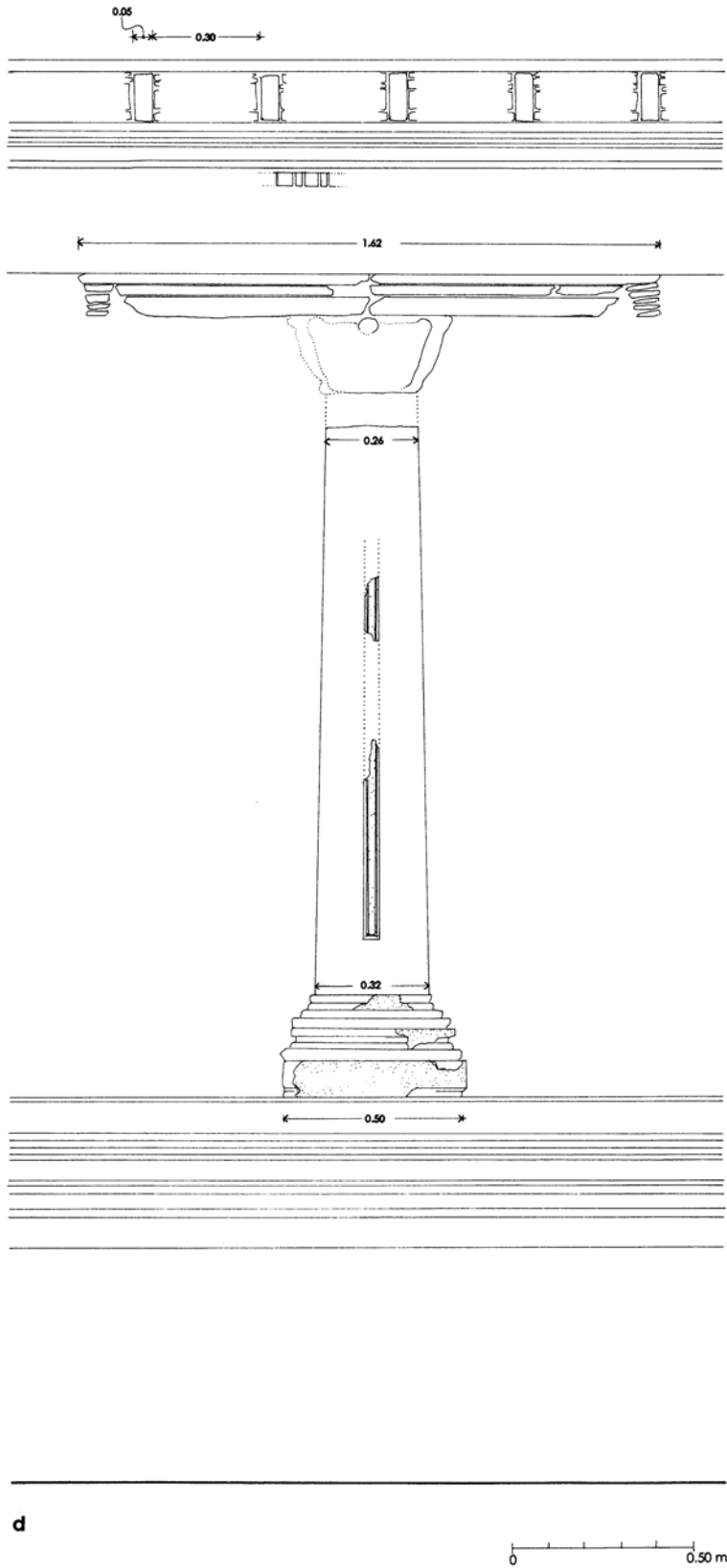

Fig. 309.
Abbasahbchina, Stupa
C. 1st storey. *d.* elevation
showing base, pilaster
and cornice. (Sabelli
1993; Martore 2003).

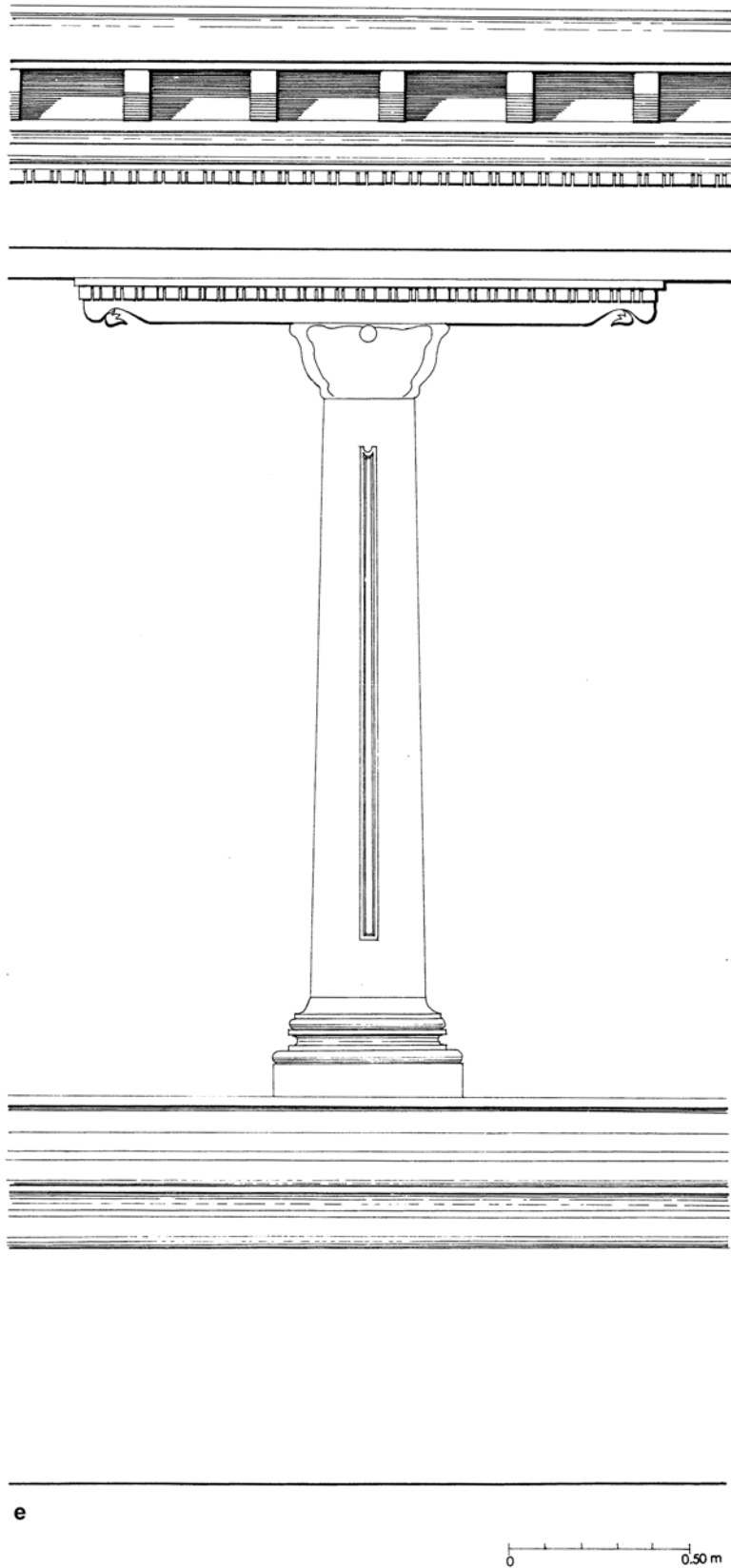

Fig. 310.
Abbasahbchina,
Stupa C. 1st storey.
e. reconstructed
elevation showing
base, pilaster
and cornice; and
reconstructed
stuccowork. (Sabelli
1993; Martore 2003).

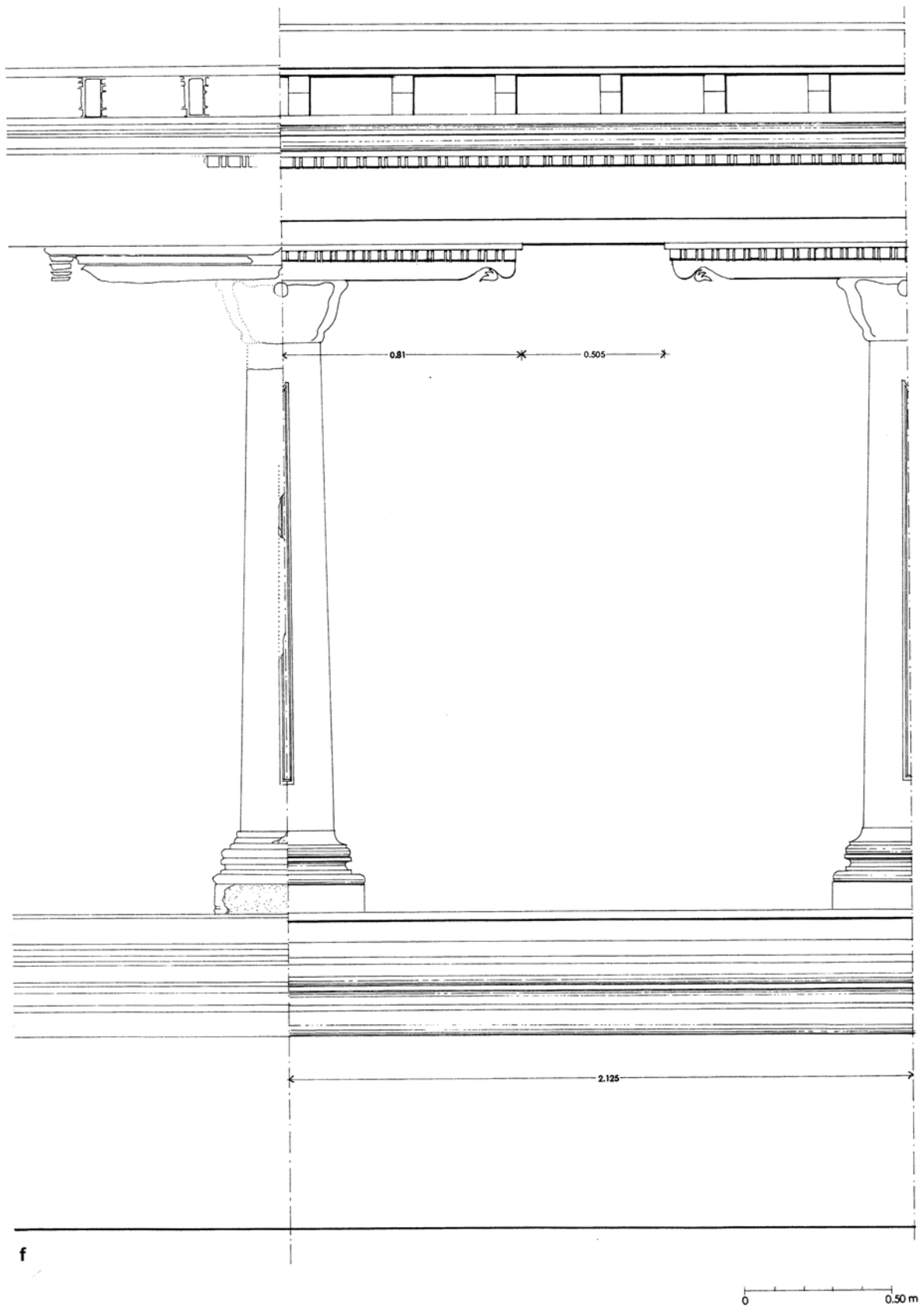

Fig. 311. Abbasahebchina, Stupa C. 1st storey. *f.* actual and reconstructed elevation showing base, interaxis between two pilasters and cornice; and stuccowork. (Sabelli 1993; Martore 2003).

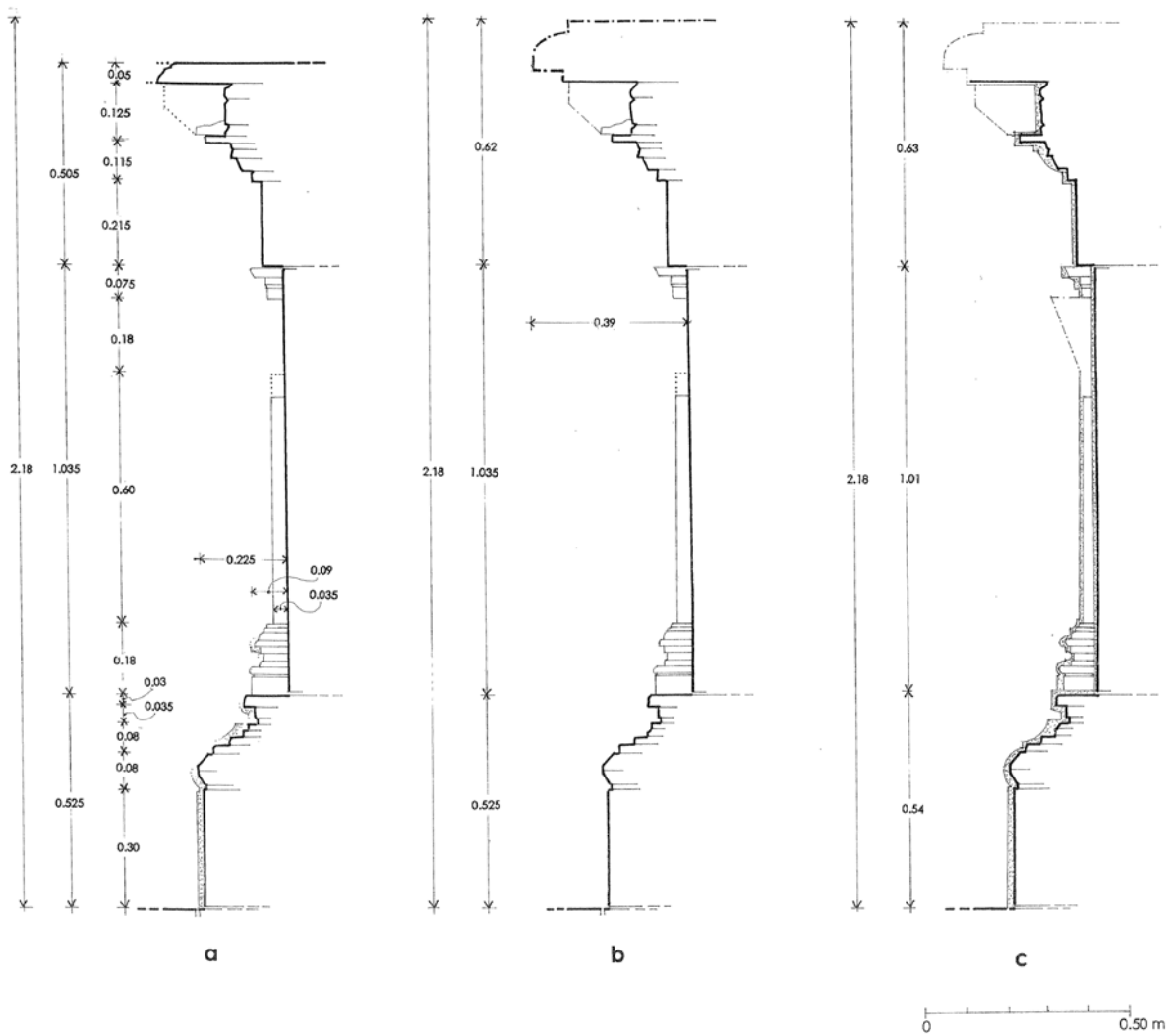

Fig. 312. Abbasahbchina, Stupa C. 2nd storey. *a.* profile. *b.* reconstructed profile, without plaster. *c.* reconstructed profile, with plaster. (Sabelli 1993; Martore 2003).

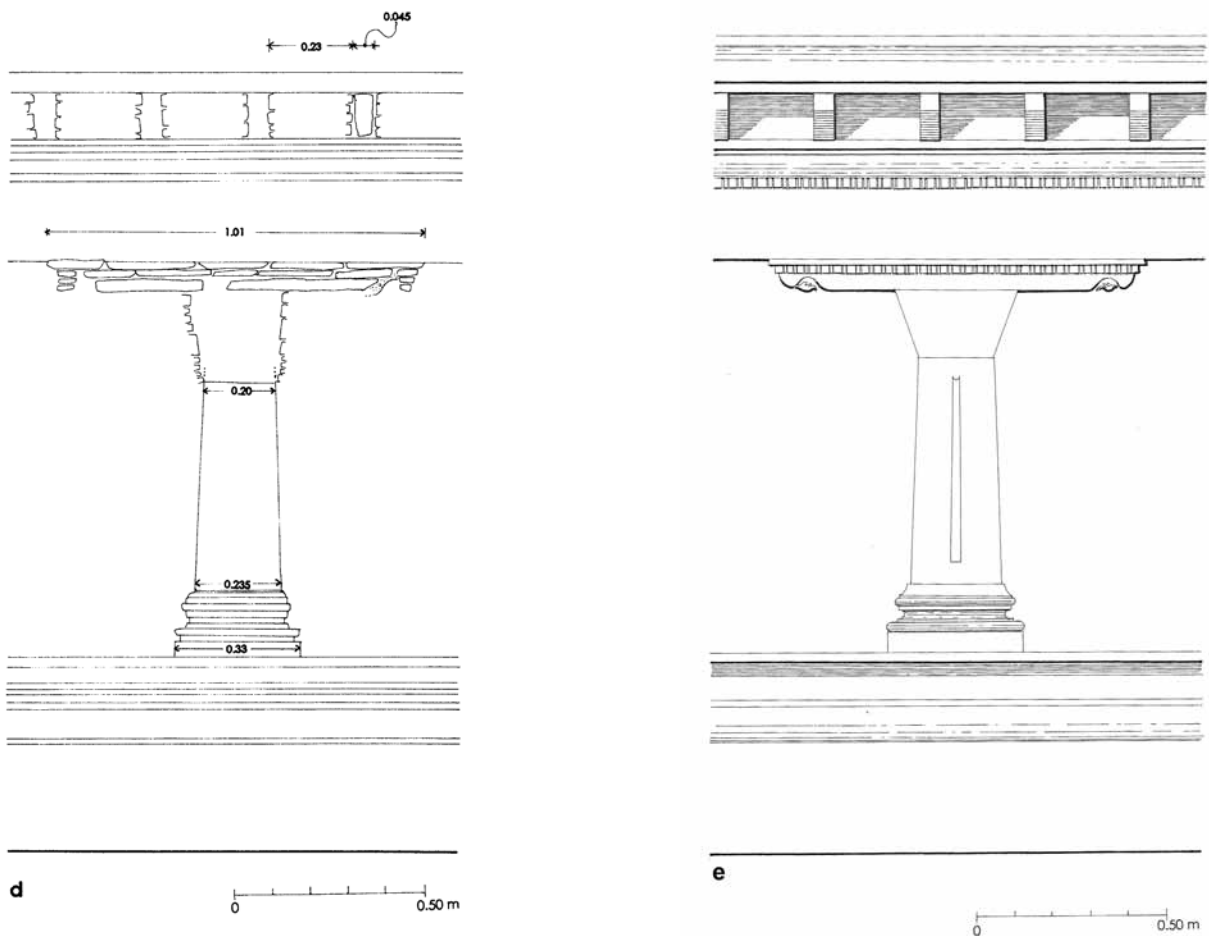

Fig. 313. Abbasahebchina, Stupa C. 2nd storey. *d.* elevation showing base, pilaster and cornice; with stuccowork. *e.* reconstructed elevation showing base, pilaster and cornice; and reconstructed stuccowork. (Sabelli 1993; Martore 2003).

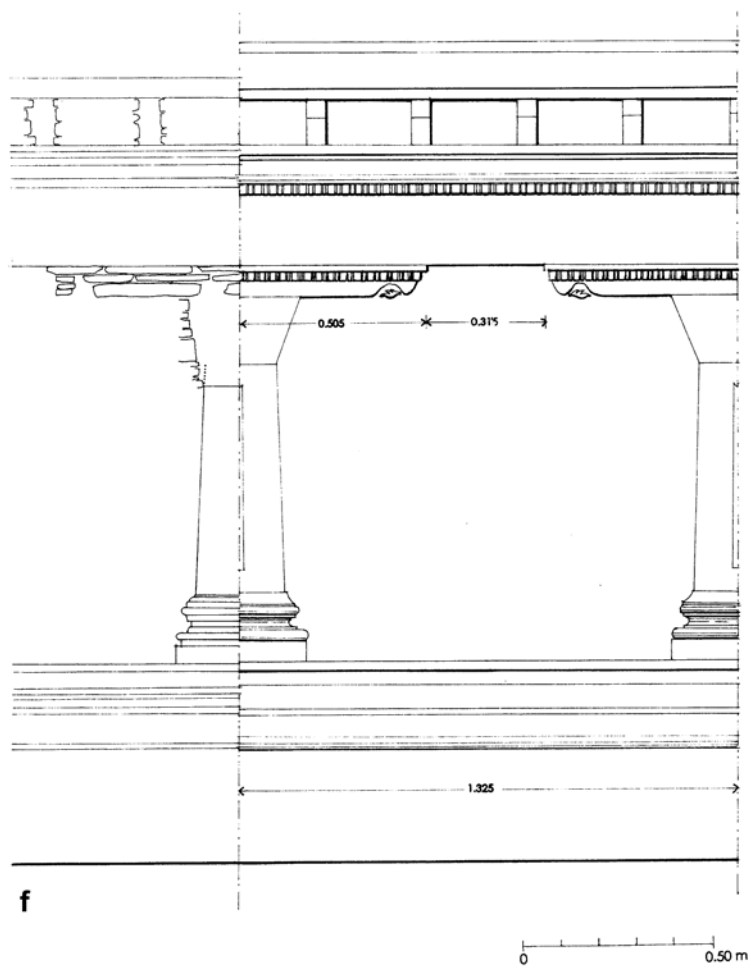

Fig. 314. Abbasahbchina, Stupa C. 2nd storey. *f*. actual and reconstructed elevation showing base, interaxis between two pilasters and cornice; and stuccowork. (Sabelli 1993; Martore 2003).

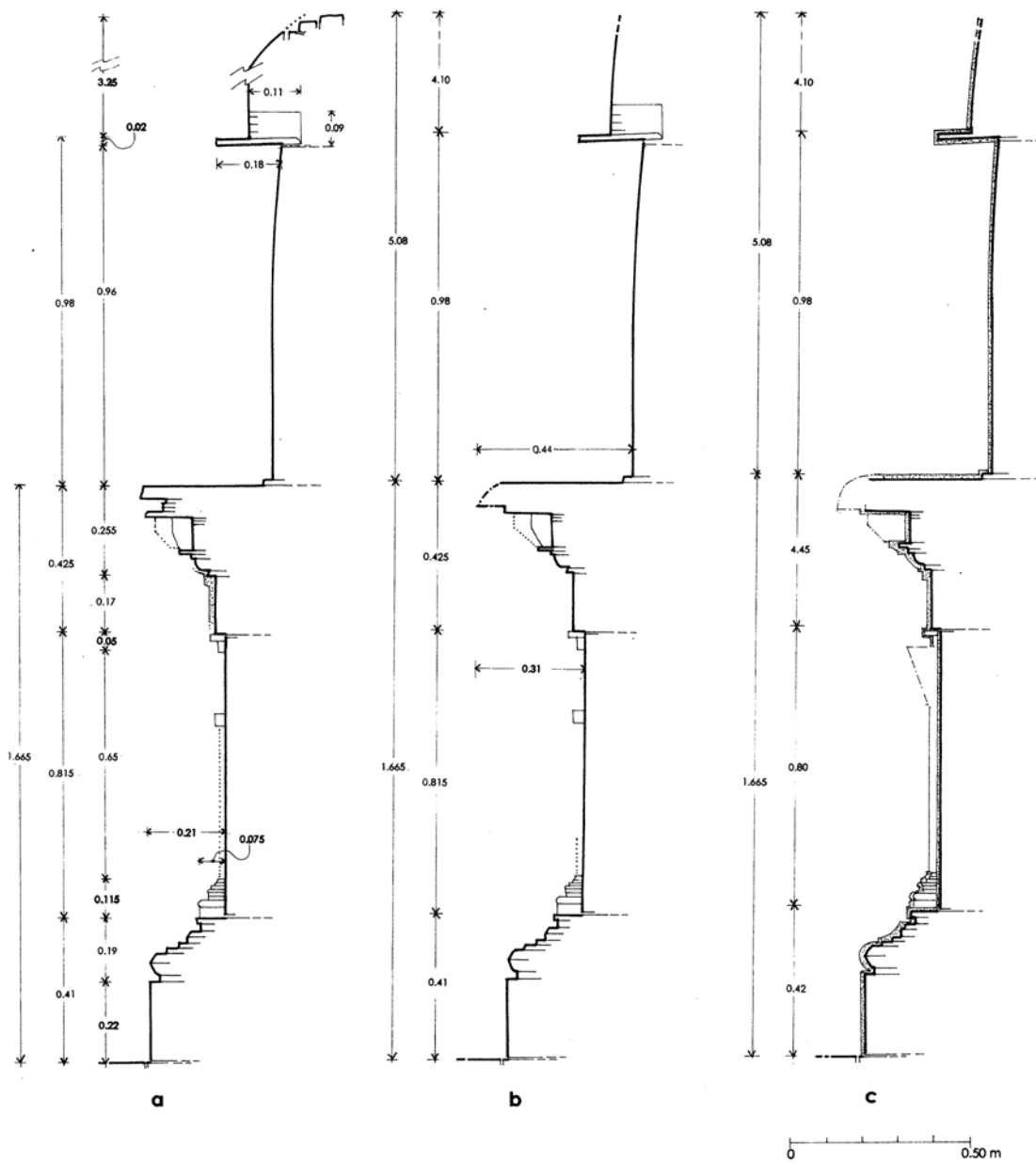

Fig. 315. Abbasahebchina, Stupa C. 3rd storey (drum), 4th storey (transition storey of the composite dome), 5th storey (raised dome); socket between 4th and 5th storey for projecting slabs. *a.* profile. *b.* reconstructed profile, without plaster. *c.* reconstructed profile, with plaster. (Sabelli 1993; Martore 2003).

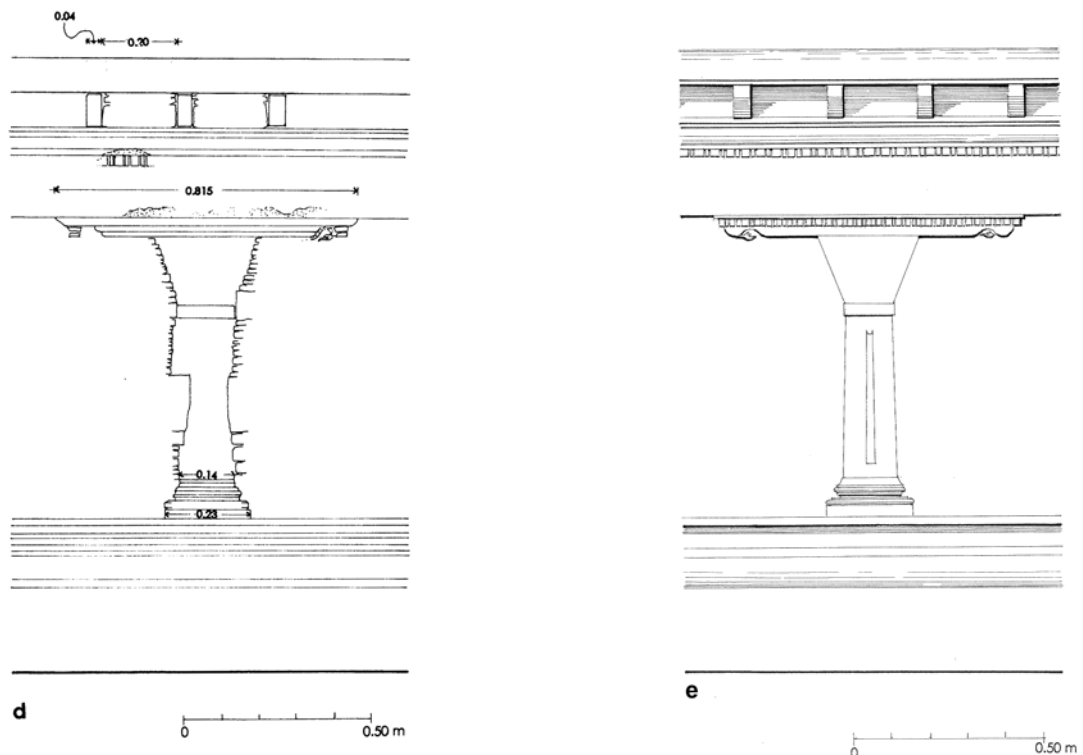

Fig. 316. Abbashehchina, Stupa C. 3rd storey (drum). *d.* elevation showing base, pilaster and cornice; traces of plaster. *e.* reconstructed elevation showing base, pilaster and cornice; and stuccowork. (Sabelli 1993; Martore 2003).

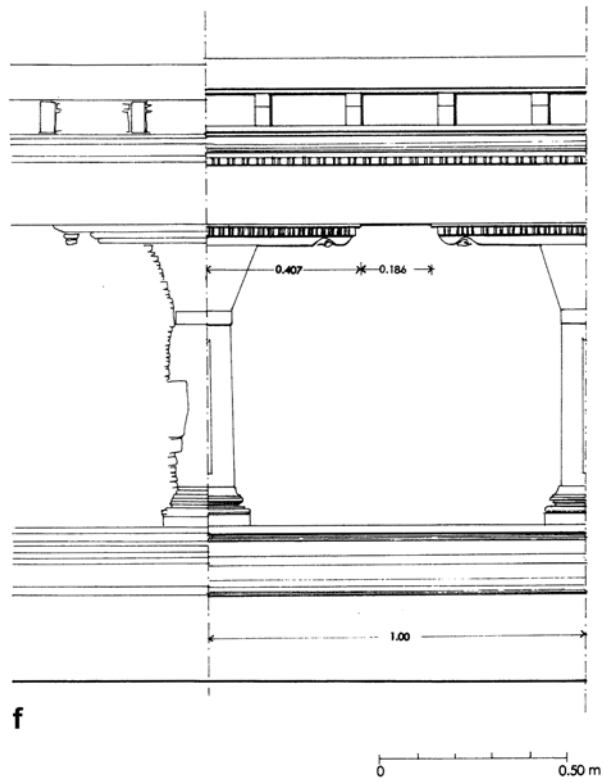

Fig. 317. Abbasahebchina, Stupa C. 3rd storey (drum). *f.* actual and reconstructed elevation showing base, interaxis between two pilasters and cornice; and stuccowork. (Sabelli 1993; Martore 2003).

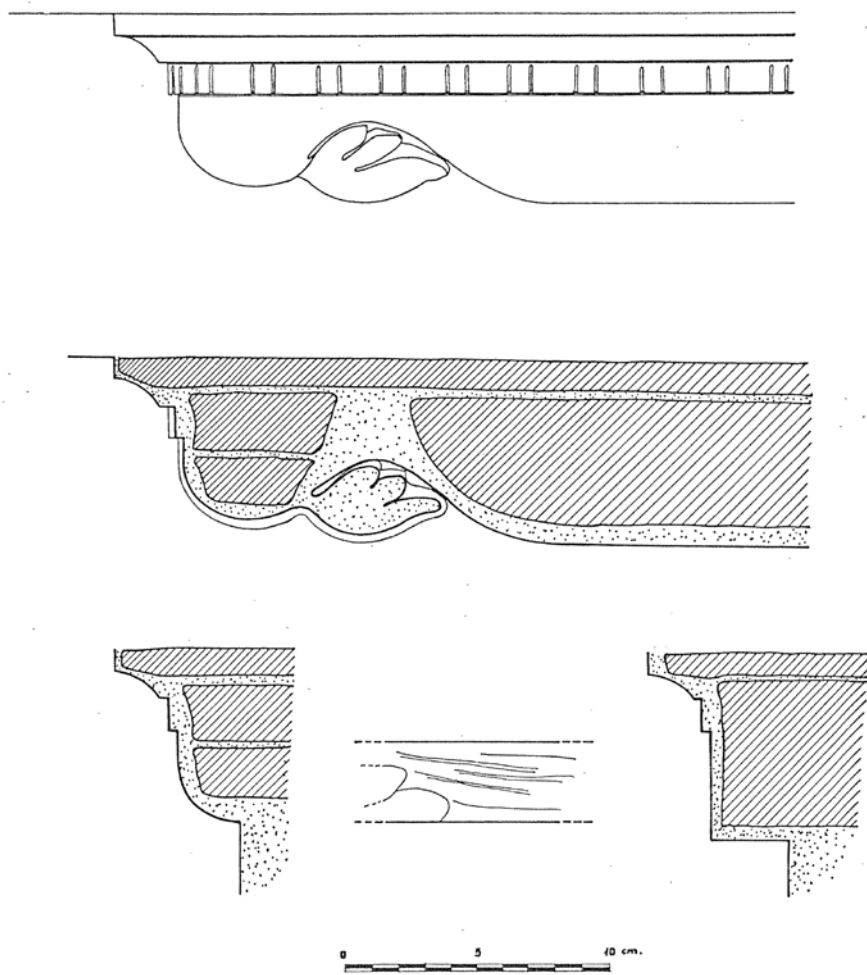

Fig. 318. Abbasahebchina, Stupa C. 3rd storey (drum). Use of stucco for architectural elements (modillion, architraved cornice) and the technique employed to apply stuccowork. (Gui 1965).

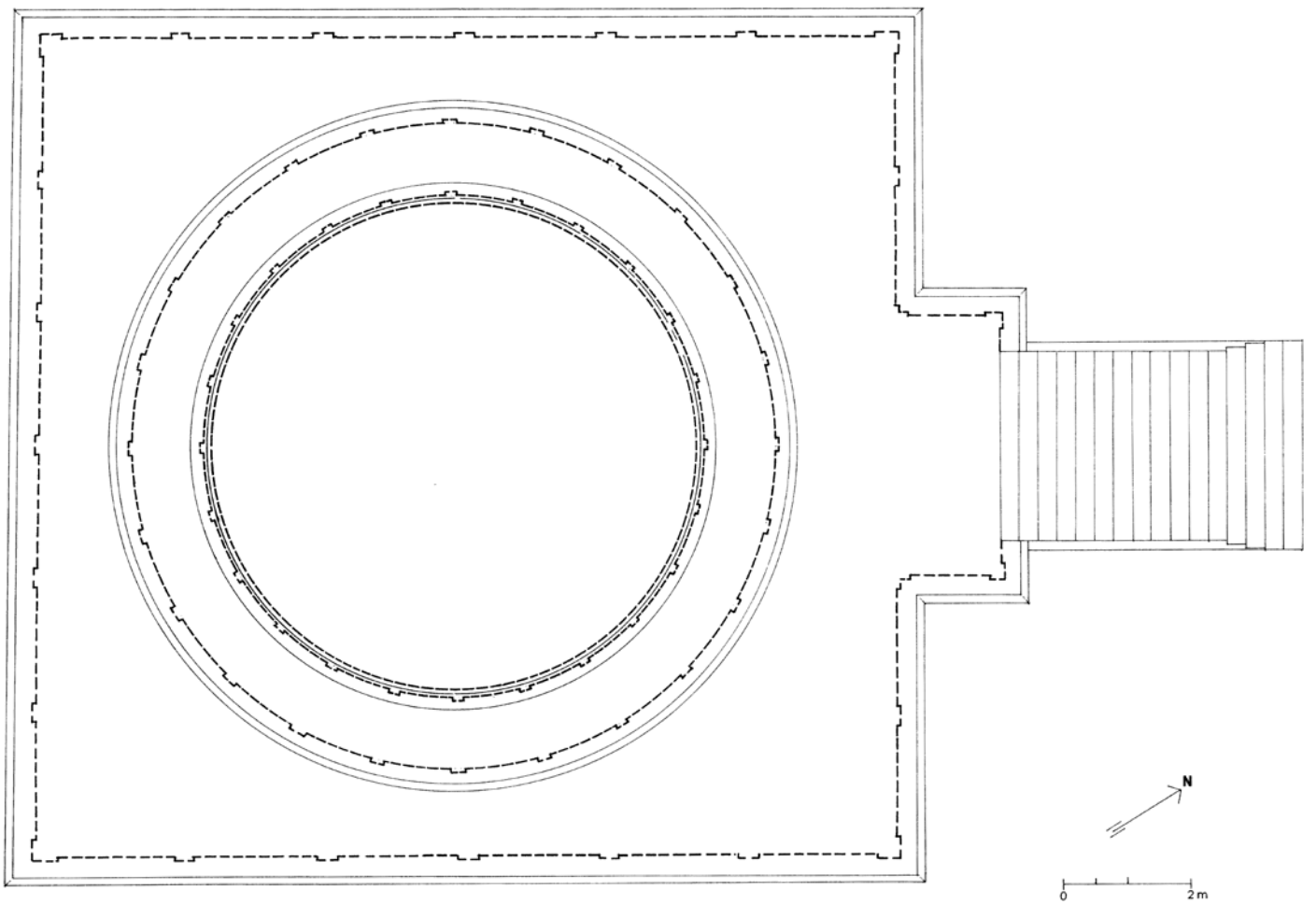

Fig. 319. Abbasahbchina, Stupa C. Reconstructed plan. (Sabelli 1993; Martore 2003).

A. Stupas

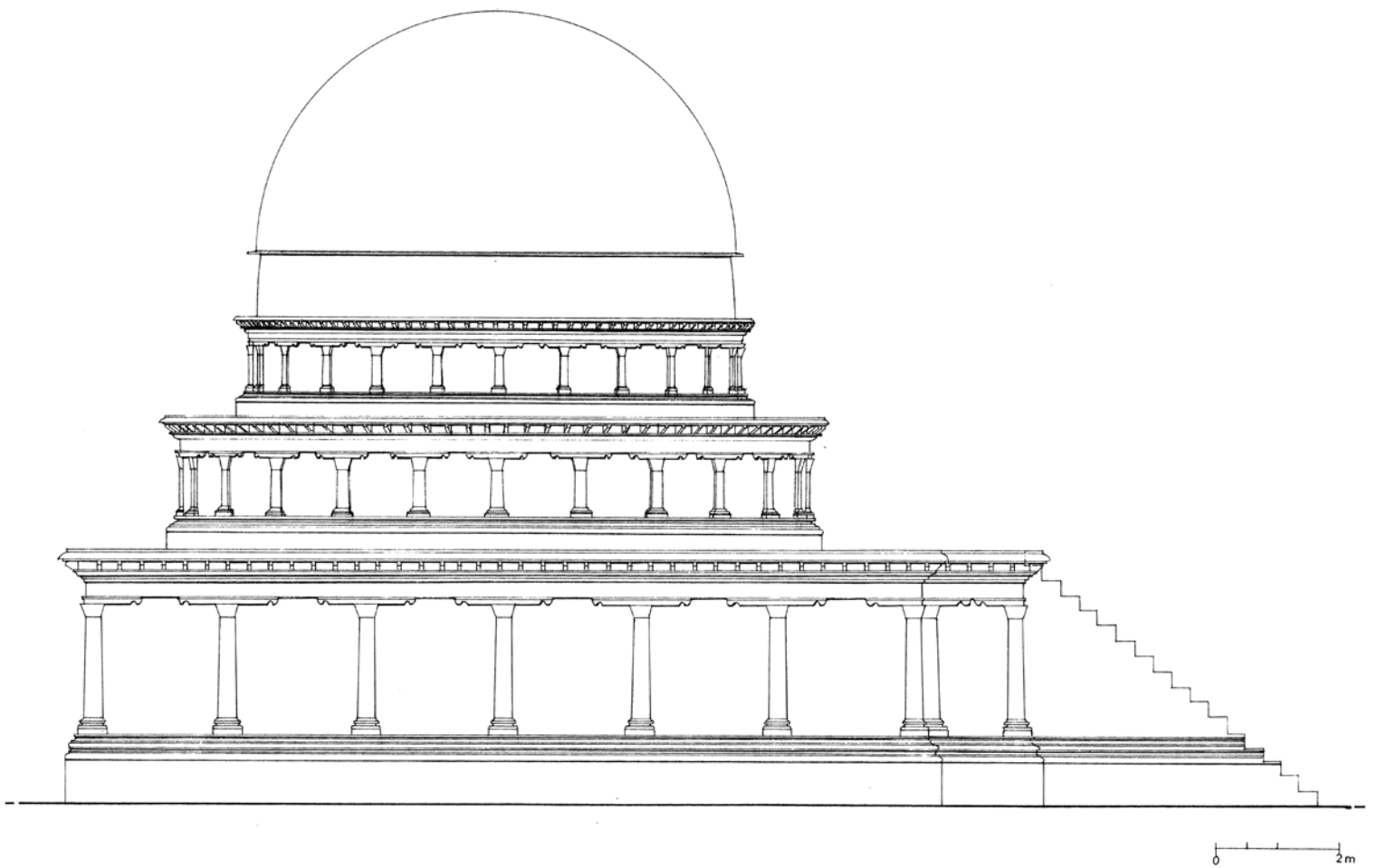

Fig. 320. Abbasahebchina, Stupa C. Reconstructed elevation. (Sabelli 1993; Martore 2003).

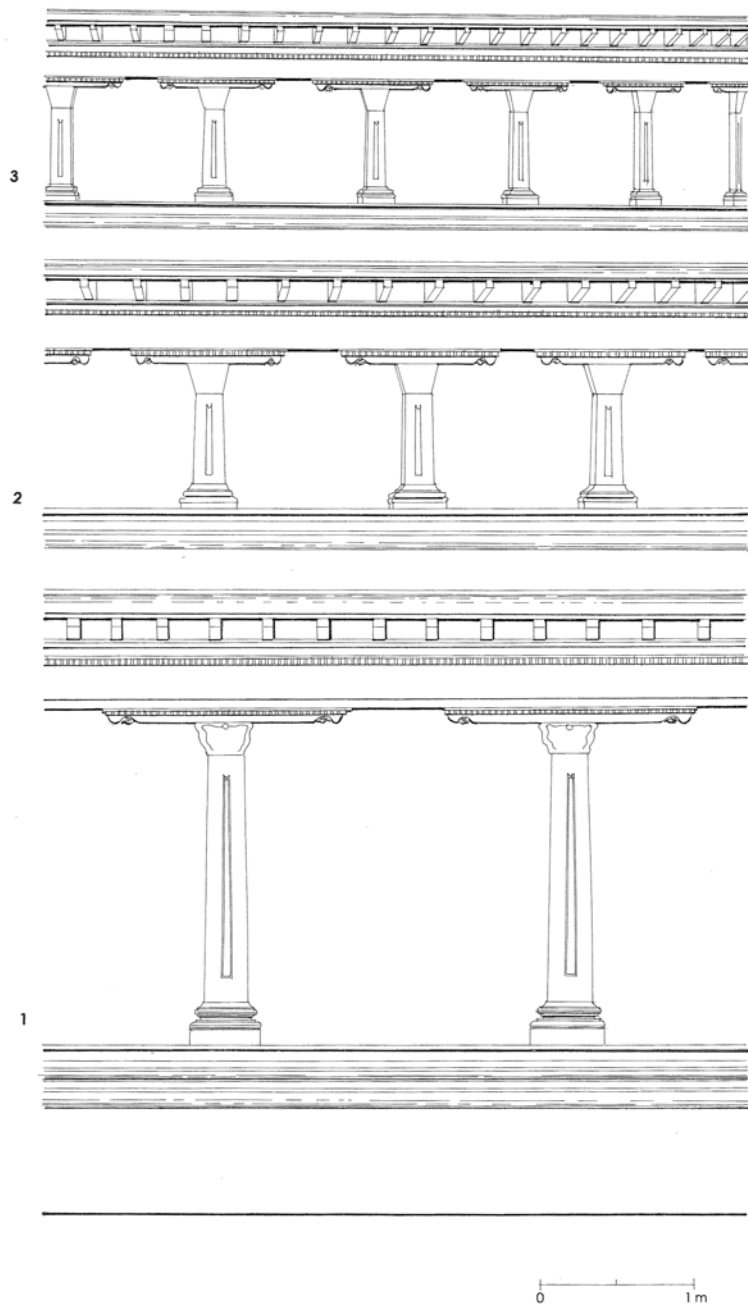

Fig. 321. Abbasahebchina, Stupa C. Reconstruction of a stretch of the 1st, 2nd, 3rd storeys. (Sabelli 1993; Martore 2003).

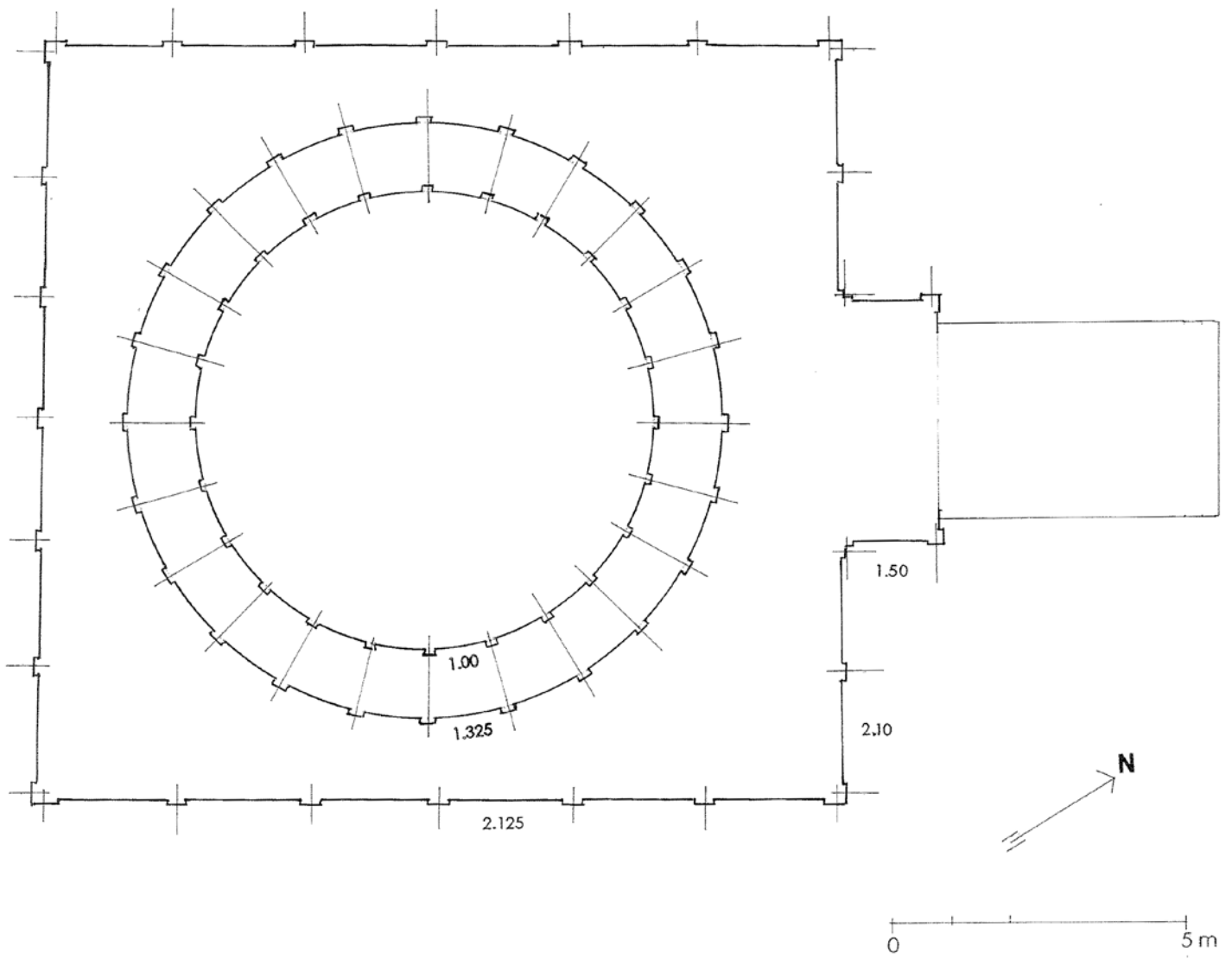

Fig. 322. Abbashehchina, Stupa C. Plan showing the scheme of the pilasters axes. (Martore 2003).

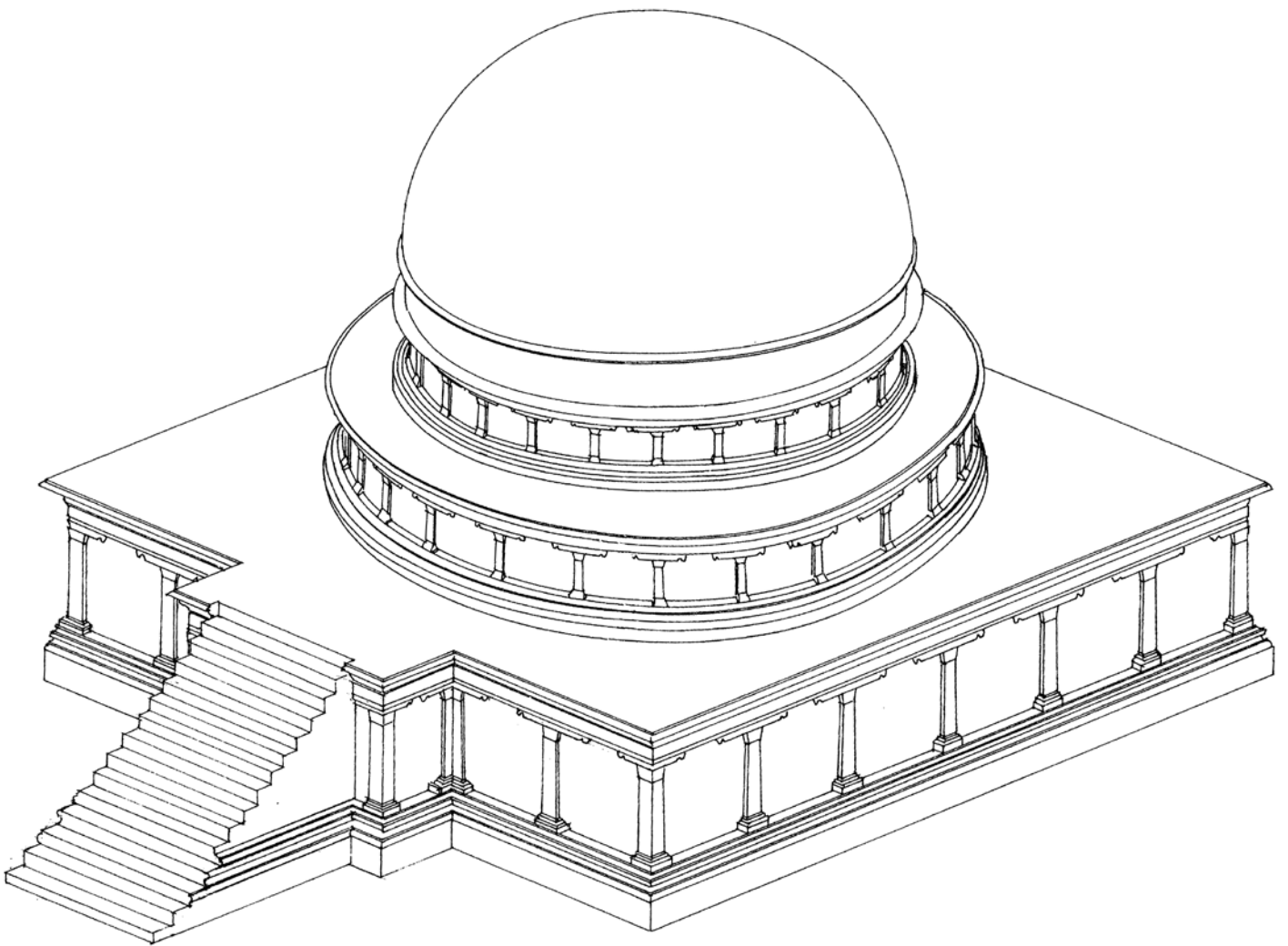

Fig. 323. Abbasahebchina, Stupa C. Axonometric view. (Martore 2003).

A11. Stupa of Tokar Dara (Najigram)

(Figs. 324-371)

The Site

Zone of Barikot.

Position: Lat. 34° 38' N; Long. 72° 13' E; SPM 43 B/2.

A short distance from Najigram, on the eastern slopes of Mt Sur-ghar, at the entrance to a narrow valley passing through them, the massive bulk of the stupa occupies a dominant position on a hill. The surrounding area abounds in ruins. To the E, near the Najigram khwar, lies a complex of structures belonging to a system constructed to regulate and distribute water; to the S, behind the stupa lies the monastery with its large courtyard; then comes a vihara on a tall base inside an enclosure. The valley narrows as it continues, with numerous constructions (dwellings, religious buildings), on the two opposite sides of the mountains; enhanced by two water springs.

The importance of this complex of ruins was fully understood by Stein who was the first to visit it in March 1926 (1930: 17) ⁽¹⁾.

⁽¹⁾ 'That the site of Tōkar-gumbat would offer a good field for systematic excavations is evident, and it must be wished that until they can be undertaken the goodwill of the enlightened ruler may put a stop to further destructive operations of those who have exploited the Buddhist sites of Swāt for the benefit of amateur collectors and more recently of antique sellers'.

Bibliography and Documentation

Stein 1929: 35-36, figs. 14-16 ⁽²⁾; 1930: 15, figs. 8-10, pl. 3 ⁽³⁾; 15-16, fig. 8 (monastery and dwellings); 16-17, figs. 10-11 (water regulating structures). Figs. 8, 10 and 9 in Stein 1930 correspond to Figs. 14, 15, 16 in Stein 1929.

Barger & Wright 1944: 24 ⁽⁴⁾.

Tucci 1958: 316-17 ⁽⁵⁾.

⁽²⁾ 'From Bīr-koṭ I visited another big Buddhist site, quite as picturesque as that just described and if anything larger (fig. 14). It lies in a small wooded dale opposite Najigrām village which is known as Tōkar-dara. Being more easily accessible it has suffered more damage at human hands. But this was amply compensated by the interesting discovery of an elaborately constructed barrage work, immediately below the big Stūpa (fig. 15). It was obviously intended to secure a permanent supply of water for what, judging from the extensive ruins of monastic quarters, must have been a very large community. The spring which once may have fed it lies far up on the hill-side (fig. 16). At the same time I found evidence that the reservoir had also been planned for the supply of systematic irrigation to the terraced fields below. It is the first example so far known to me on the Frontier of an ancient engineering work designed for this double purpose. Months would probably be needed for the complete excavation of the ruins higher up; they are thickly overgrown by thorny jungle and include a large quadrangle with monastic quarters. Even confining myself to mere rough survey and photographic work, I found it difficult to do it justice in a day'.

⁽³⁾ 'Stūpa di Tōkar-dara. — From the village of Najigrām, which nestles at the western foot of this spur and was reached after about three miles' march from Bīr-koṭ, there came into view westwards the conspicuous ruined Stūpa known as *Tōkar-gumbat*. It lies about half a mile from the village at the entrance of a small picturesque glen known as *Tōkar-gumbat* (fig. 9), wooded on its higher slopes and filled with thick thorny jungle below. The site proved far more extensive and interesting than expected at first sight, a series of structures up the glen being hidden behind the large ruined Stūpa. This rises close to the left bank of the torrent bed and, though dug into both from the north and south-east, has suffered less destruction than the Stūpas nearer to Bīr-koṭ. As shown by the sketch-plan, pl. 3 [lower left], its dome is raised on three bases of which the lowest measures 66 by 68 feet. The second is square and carries the third which is circular as in all Swat Stūpas.

'The drum of the dome which rises above this measures 35 feet in diameter. It is decorated with two cornices formed as usual by thin vertical slabs of stone projecting at intervals between horizontal courses. The dome proper appeared to be of hemispherical shape. It had suffered too much damage for the height to be exactly determined. On its broken top the inner face of walls lining a shaft, 4 feet square, and descending towards the centre could be distinguished. Through it treasure-seekers had burrowed downwards.

'[...] The whole of the drum and dome had been faced with roughly dressed white slabs and the interstices between them filled in Gandhāra fashion with columns of small pieces of dark stone. The same material was used for the packing which divides the courses. A flight of stairs 8 feet wide led up to the second base from the east. Rank vegetation covered the whole of the Stūpa bases and rendered exact measurement difficult'.

⁽⁴⁾ 'On the opposite side of the valley, about half a mile south-west of Najigram village, a narrow rift in the hills shelters the ruins of Tokargumbat — the large stūpa, monastery buildings and barrage described by Sir Aurel Stein. An experimental clearance of the western side of the stūpa base produced a few extremely battered stone carvings, and portions of the fallen umbrella of the stūpa'.

⁽⁵⁾ 'After Natmera, the ruins of Najigram come in sight, consisting mainly of walled terraces of Gandhāra type. Following the ridge of the hill one finds after climbing up the rocks the ruins of a big stūpa, and one enters the old street which passes through a narrow gate; in some places the steps are preserved. To the left, a wide square space is delimited and supported by huge walls in diaper work. Since there is no trace of any building and the walls end abruptly, my impression is that a big water reservoir was there: this impression is corroborated by the local tradition, according to which right at the corner of the opposite slope there was, until a few years ago, a spring now dried up. But the trees which always shelter the springs are here still, generously bestowing their shade. Of course the real destination of the ruins will be disclosed by the spade of the archaeologist. A little higher up are the ruins of a stūpa, greatly damaged. Extensive remains are scattered all over the slopes of the steep hill.

'To the S. W. of Najigram at a distance of about two km., stands Tokar. In this locality I was much impressed by the barrage works, but what surprises one is rather the extensiveness of the remains. In Togar, Tokar we

Faccenna 1986: 60-61, ns. 23-24, figs. 5-6, pls.5-6; Faccenna, Nabi Khan and Nadiem 1993: 265, n. 3.

Gui and Cimmino 1965: graphic survey of the stupa.

Tilia 1980.

Martore 1986, 2003: graphic survey of the stupa.

Khan M. Ashraf 1993: 59-62, pl. VII, figs. 46-47.

Nascari 1993: short photographic campaign.

Sabelli 1993: graphic survey of the stupa.

Faccenna 1995a: 502-509, figs. 230-237 (sketches by F. Martore); 1995b: 2, figs. 7-10.

Behrendt 2004: *passim*, figs. 112-113.

Khan A. Nazir 2004: 302-16.

Photographic campaigns were carried out over time, mainly by Taddei in 1958 and 1959, and by Scerrato 1959.

In more recent years, after 1993, several events have been reported that produced changes both in the monument as a whole and in its details: excavation of the sides of the 1st storey and stairway, the room on the S side of the ramp, the basement of the corner columns; also of several stupas along the sides by the Department of Archaeology Government of Pakistan (Khan M. Ashraf); reconnaissance work for the execution of the Archaeological Map of the Swat Valley by Vidale and Olivieri with the collaboration of Spagnesi (2005), in which it is reported (Olivieri & Vidale 2006: 99, fig. 48; Spagnesi 2006: 161-62, figs. 17-22); photographic campaign of Spagnesi (2005) to survey the monument and the smaller stupas; lastly, a more detailed investigation of the water system (Olivieri & Vidale 2006: 131-38) and of buildings located in the valley beyond the monastery (vihara on a basement inside an enclosure, dwelling units along the mountain slopes enclosing the valley). The principal monument and the complex as a whole are undergoing constant transformation. This 'dynamic' situation, consequent to the various phases of cleaning and excavation work, both preceding and following 1993, is reflected in the sketches and photos.

find two big stūpas; one of them is well preserved, while of the second to the south east only the plinth and the basement remain, although it is clear that this also was of huge proportions. Between the two ruins the *vihāra*, the north-western wall of which presents a row of square rooms, all vaulted: then we find the high walls still extant of a big room which was probably the Assembly Hall. A little below the big stūpa the ruins of another stūpa are visible. In the narrow valley enclosed by the steep slopes of the towering mountain there are many ruins of small buildings.

'The place is certainly one of the greatest monastic settlements of the whole Swat. Below, stretches a fertile valley gently sloping towards the river; foundations and walls are everywhere visible.

'That the Najigram settlements and stūpas were of considerable interest, is shown by a well-preserved casket in steatite which was found among their ruins, containing a small golden box with some relics, and also it seems a birch-tree leaflet which has since disappeared: according to what I was told the casket was given to the Wali Saheb'.

The Stupa

Recently excavated (after 1993) in the lower aprt of the quadrangular shaped storey, previously largely covered by collapsed material, with dome and core corroded, the stupa is still impressive with its massive construction.

It consists of a 1st storey, rectangular in plan, with stairway facing W, three storeys with circular plan, the lowest one of which having a larger diameter than the two above, and the dome, with the same diameter. The stairway continues through the 2nd storey, as far as the 3rd, in the front of which there is a niche. On the 1st storey, four columns rise in the four corners, part of the pedestals have been conserved.

The facing is made of rows of relatively small (striated) marble or fine-grained gneiss blocks or fine-grained gneiss, roughly dressed, abundantly at the side of and between the rows of blocks of small relatively thick fine-grained gneiss slabs. The core consists of slabs and chips laid in horizontal rows, bonded with clayey soil. Traces of plaster and red colour are still visible.

1st Storey, Quadrangular in Plan

Previously largely buried, the full height of the wall and the base were not visible. We learned about them from the sketches made by Gui and Cimmino (1965); we now have a more extensive view of them.

The cornice is composed of small and thin slabs, which make up the profile of fillet, ovolo, reverse cavetto; above this are the brackets made of vertically laid small slabs separated by bracket spacers made of superimposed small slabs. Several (eight) are conserved on the N side. The bracket slabs have a worn and indefinable profile; brackets and bracket spacers are included between two projecting filleted slabs. Of the upper part of the cornice, terminating in a reverse ovolo and with a coping slab, only the core is left, which thus reaches as far as the 2nd storey. Extensive traces of plaster have been conserved on the walls and the mouldings.

The plaster defines the profile of the cornice mouldings. The various phases of its working are visible. The plaster first applied to the wall underlies that of the various mouldings applied in three stages, thus revealing the procedure of working from bottom up (fillet and ovolo, cavetto, fillet).

Traces of band of red colour appear between the fillet and the cavetto of the cornice probably to mark the moulded parts.

The base is composed of cavetto, torus and plinth made using larger and smaller slabs with a plaster coating of which sections appears with several superimposed layers.

On the W side lies the stairway with its ramp of steps and projection with landing, visible in the profile, still covered with collapsed material. On the basis

of the known mean measures it is possible to calculate 26 steps and an inclination of 36° with the point of landing with the tread of the last step. It is not possible to determine the presence of the base or the cornice of the ramp, which is thus depicted without them in the sketch.

On the S side of the projection a small opening is found opening into a quadrangular shaped room with a raised hemispherical domed vault (width 1.64, depth 2.50; h. at the top of the dome 2.335 with wall 1.435 and dome 0.90). The doorway with a threshold raised above the base moulding (c. 0.80, and h. c. 1.55 above the external plane) has an undecorated opening with a monolithic architrave, jambs slightly tapering above (lower width 0.54 and thickn. 0.50 at two sections of different level of the architrave). While the right hand jamb is almost flush with the wall of the stupa storey, the doorway is wholly shifted leftwards with respect to the internal room.

The outer wall containing the doorway displays a simple vertical abutting joint at nearly half the width of the projection which is partly contradicted by blocks connecting it to the rest of the project, particularly in the part above the roof covering of the room itself. This solution is probably linked to the execution of the entire work. It recalls other examples (Stupa of Jurjurai); it is difficult to determine its function and use – practical or religious.

2nd Storey, Circular in Plan

Set back from the 1st storey by 2.35 to the S and 2.40 to the E, with a diam. at the wall of 15.50, it has retained the base with the plinth made of blocks and small slabs, and torus and cavetto made of small slabs. The cornice displays a fillet and an ovolo; the remaining upper part of the projection is missing, the profile of which, on the basis of the alternation of the slabs of varying thickness may be assumed to have repeated the shape of the 1st storey cornice; it reaches as far as the reverse ovolo and the coping slab.

Abutting this to the W is the stairway with its flight of steps and short projection, most of which is missing. On the latter, viewed in the N corner, the base and cornice mouldings continue, while they are missing on the ramp; the latter, now missing, may be reconstructed as having 12 steps and an inclination of 35° .

Springing from the four corners of the upper plane of the 1st storey, corresponding to the 2nd, are the columns, of which the remains of the dado of the pedestals provided with base with plinth, three-sided bevelled torus and cavetto, made of slabs are visible. The columns are very close to the circular storey, leaving a wide passage free on the outside.

3rd Storey, Circular in Plan

Set back from the 2nd storey by 1.25, with a diam. at the wall of 13.00, lays on small foundation slabs at the level of the wall base. Both base and cornice repeat the structure and profile of the lower storey. An interesting construction event should be noted in the upper part of the cornice. The section comprising the brackets and the bracket spacers abuts the wall of the 4th storey, in which the slabs above of the fillet and ovolo are inserted. This section was implemented subsequently as is confirmed also by the plaster found under the small slabs of the bracket spacers. The reason underlying this solution may conceivably depend on the way the work was organized. As usual, the cornice lacks a coping slab above the reverse ovolo.

In the section corresponding to the ramp of steps of the 2nd storey there are traces of a linear podium. The mouldings of the base of the circular storey give way to a wall made of blocks and small slabs, very short sections of which are still conserved. Blocks and slabs protrude here and there, probably associated with the core, wall and base mouldings of the podium. It may be conceived of as protruding slightly beyond the line of the body of the stupa with an elevation suggesting a wall, also linear, in the shape of a shallow niche. It is not possible to determine the transition between this and the cornice of the circular storey nor whether it continued as far as the 4th storey.

4th Storey, Circular in Plan (Drum)

The wall, with no base mouldings, springs from the cornice of the 3rd storey, almost flush with the wall of the latter storey and rises vertically. From the construction standpoint, as we have already seen, it is supported by means of a row of blocks on the lower part (ovolo and cavetto) of the 3rd storey cornice. Between the first and second row of blocks the projecting slabs of the fillet and of the reverse ovolo above the brackets have been inserted.

The wall has a reduced cornice composed of brackets and bracket spacers between two fillets; above this is the reverse ovolo, lacking a coping slab.

5th Storey, Dome

The dome springs directly from the cornice of the storey below and is flush with the relative wall. Nothing is left of the facing.

Towards the top of the core there is a quadrangular shaped room, three sides of which have been conserved; Stein (1930: 15, pl. 3) observed it intact and defined it as having a square plan with a side length of 4 feet, which was again measured by Gui (1965) as indicated in the plan and cross section of its present conditions.

A. Stupas

Situated half way along the width of the dome, about 3.80 above the wall base and c. 2.00 below its hypothetical top, with an undefined plan view, it has a max. conserved depth of 1.30; it was built using parallelepiped shaped blocks probably using small slabs as transition elements.

Chattravali Elements

The collapsed elements on the surface of the 2nd storey (nos. 1-5) are deemed probably to belong to the stupa. No. 2 has not been included in the series of the pinnacle reconstruction as its diameter (c. 7.00) cannot be calculated accurately. Slab no. 6, lying in the collapsed section near the S wall of the stupa stairway, near the entrance to the small room which is visible only in section (Faccenna 1995a: figs. 230, 232) and has now been removed and placed elsewhere, was probably part of the harmika.



Fig. 324. Stupa of Tokar Dara (Najigram). General view, from S, towards the valley. (After Stein 1930: fig. 8 [=1929: fig. 14]).



Fig. 325. Stupa of Tokar Dara (Najigram). General view, from W. (After Stein 1930: fig. 9 [=1929: fig. 16]).

A. Stupas

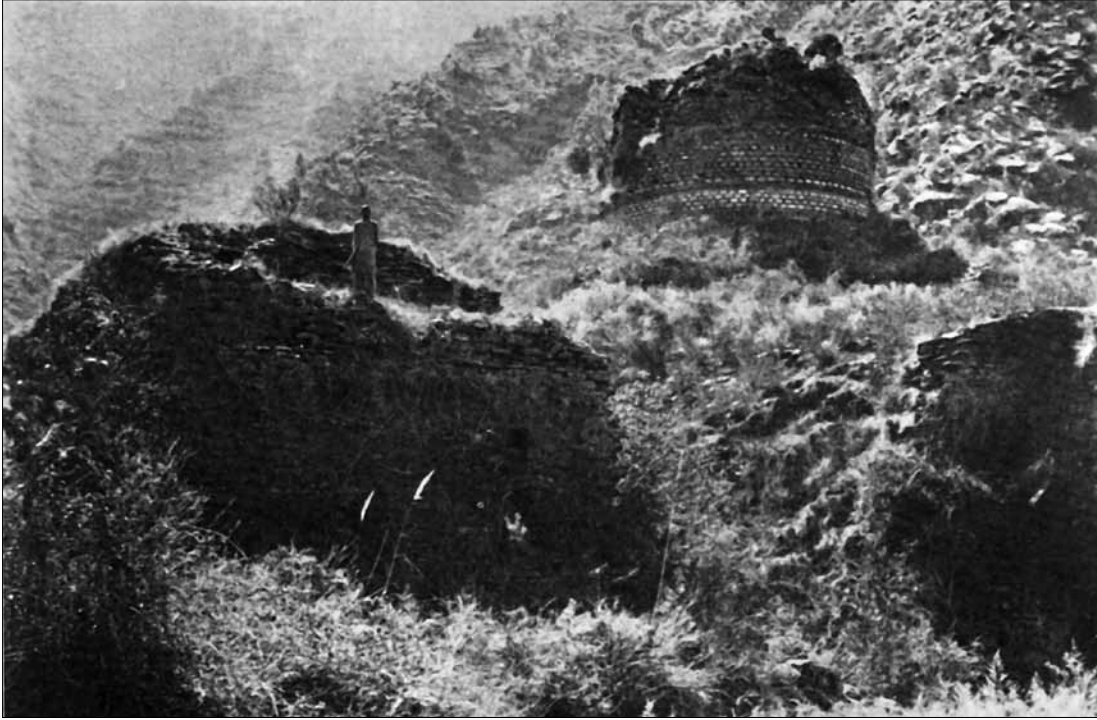

Fig. 326. Stupa of Tokar Dara (Najigram). General view, with an aqueduct in the foreground, from N. (After Stein 1930: fig. 10 [=1929: fig. 15]).



Fig. 327. Tokar Dara (Najigram). Stretch of the aqueduct, N side. (After Stein 1930: fig. 11).

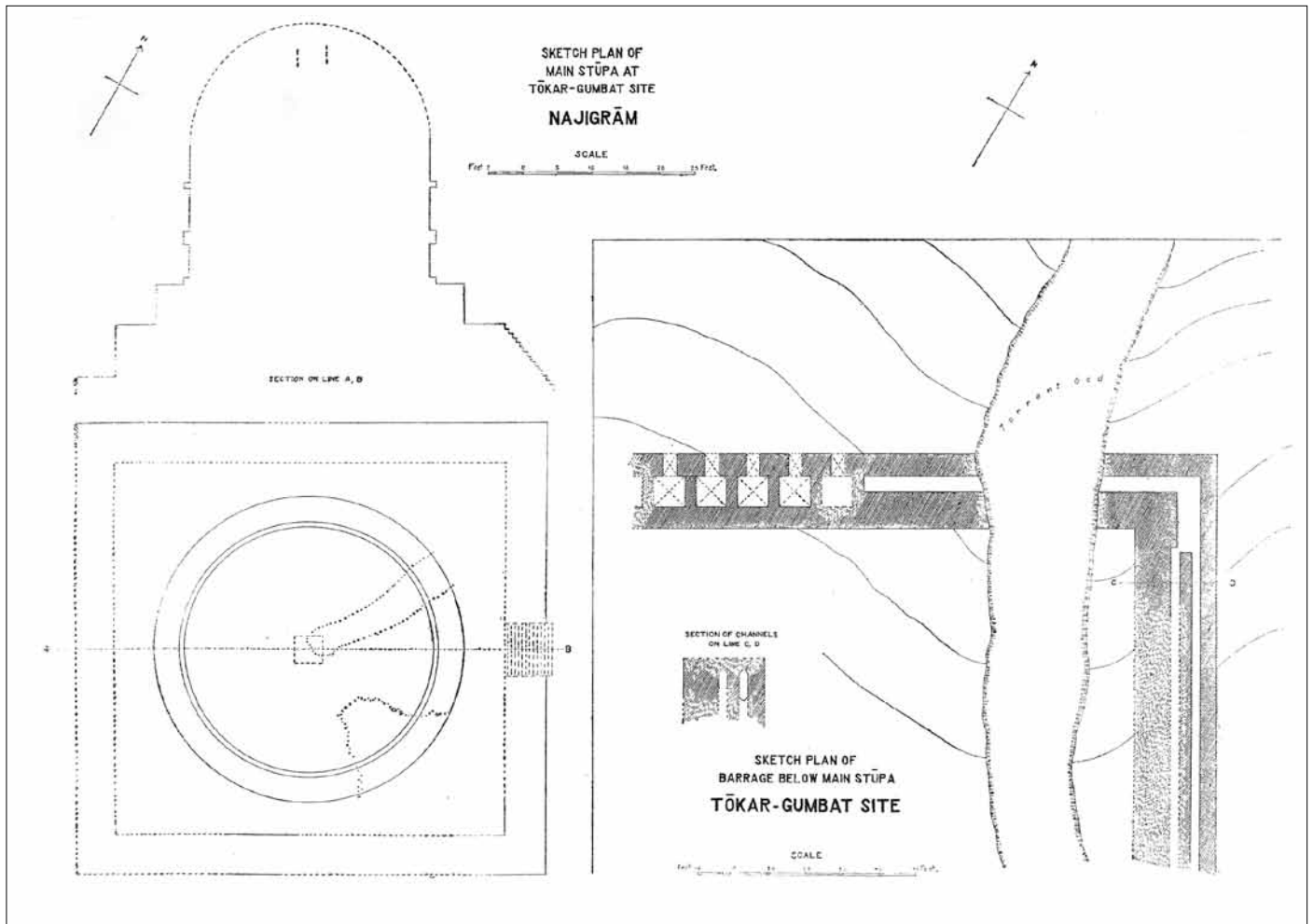

Fig. 328. Stupa of Tokar Dara (Najigram). Sketch plan and elevation, on the left, and stretch of the aqueduct (plan and cross section), on the right. (After Stein 1930: pl. 3, at the bottom).



Fig. 329. Tokar Dara (Najigram). View of the stupa. (Benuzzi 1955).

A. Stupas

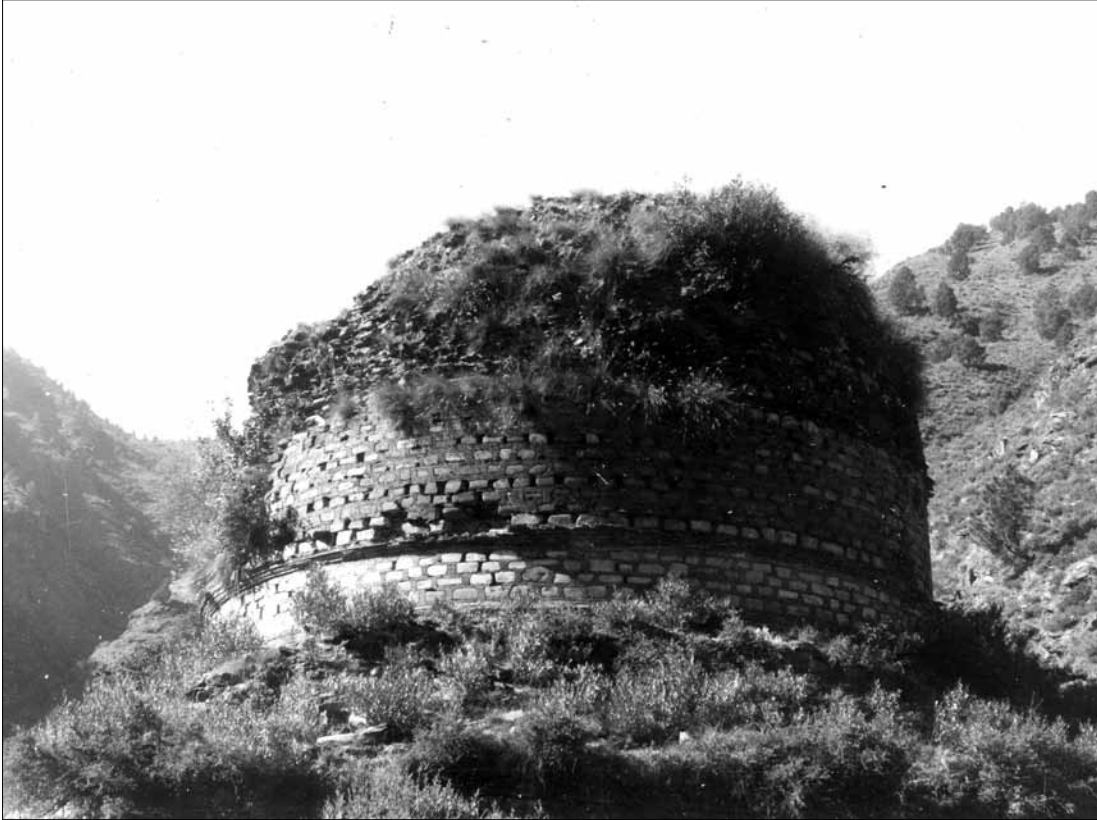

Fig. 330. Tokar Dara (Najigram). General view of the stupa. (Scerrato 1959; Neg. L 35/26).



Fig. 331. Tokar Dara (Najigram). General view of the complex; from N to S; from right to left: aqueduct, stupa, monastery, vihara. (Spagnesi 2005).



Fig. 332. Tokar Dara (Najigram). General view of the complex; from W to E; from right to left: stupa, monastery, vihara. (Spagnesi 2005).

A. Stupas





Fig. 333. Tokar Dara (Najigram). Monastery; detail of the dome of a cell. (Spagnesi 2005).



Fig. 334. Tokar Dara (Najigram).
Aqueduct. (Nascari 1993).



Fig. 335. Tokar Dara (Najigram). Vihara, N side with flight of steps. (Spagnesi 2005).



Fig. 336. Tokar Dara (Najigram). Vihara, N side, on the E of the flight of steps. (Spagnesi 2005).



Fig. 337. Stupa of Tokar Dara (Najigram). W side with the stairway. (Spagnesi 2005).

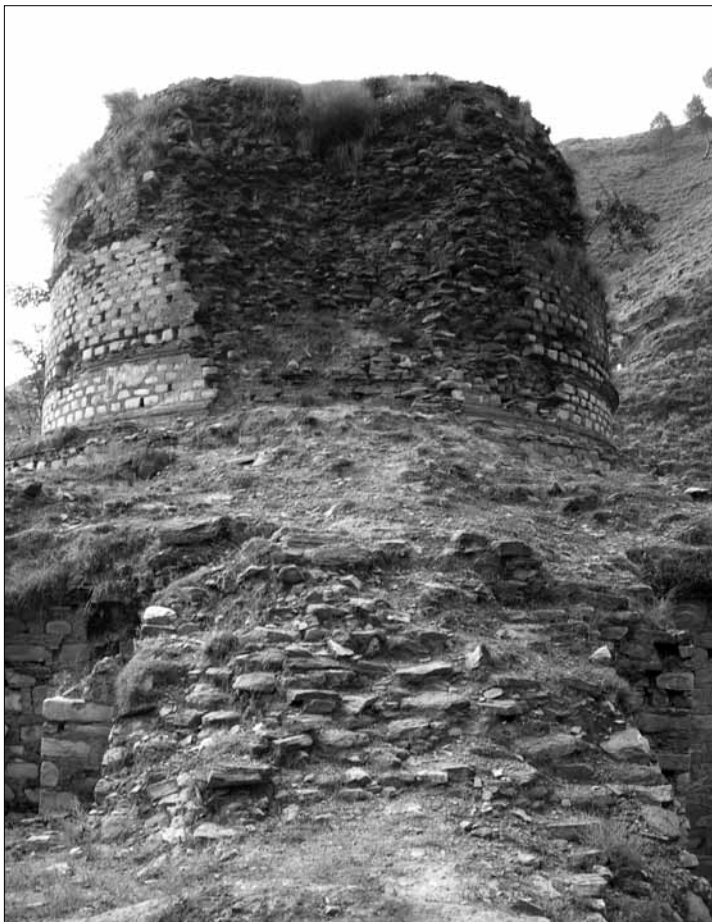

Fig. 338. Stupa of Tokar Dara (Najigram). W side with the stairway; detail. (Spagnesi 2005).

A. Stupas



Fig. 339. Stupa of Tokar Dara (Najigram). W side, detail showing the S side of stairway with projection and a stretch of the 1st storey. (Spagnesi 2005).

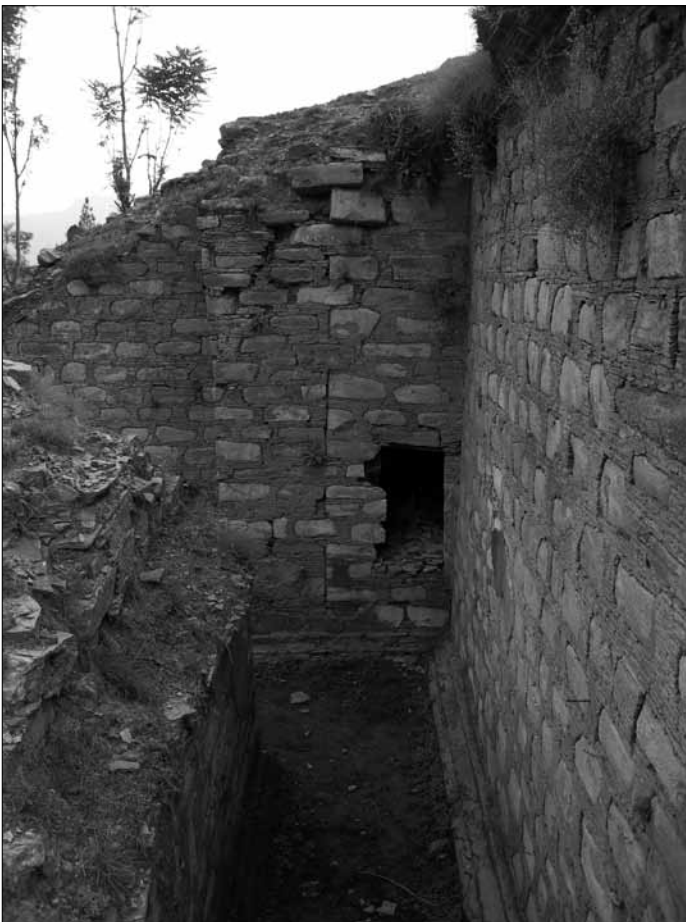

Fig. 340. Stupa of Tokar Dara (Najigram). 1st storey, W side, S side of the stairway with opening of the room in the projection. (Spagnesi 2005).

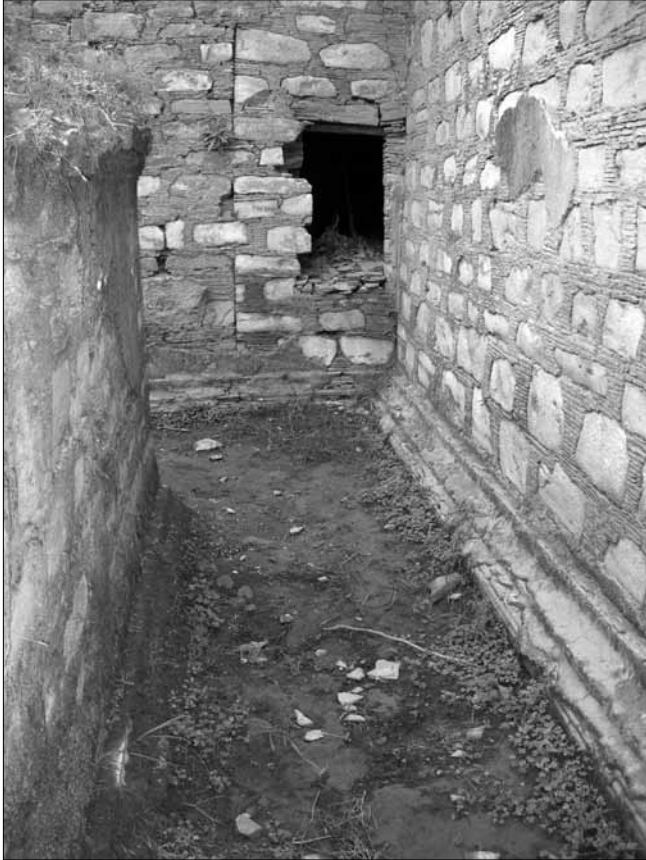

Fig. 341. Stupa of Tokar Dara (Najigram). 1st storey, W side, S side of the staircase strairway with opening of the room in the projection; detail. (Spagnesi 2005).



Fig. 342. Stupa of Tokar Dara (Najigram). 1st storey, W side, N side of the stairway with projection; detail. (Spagnesi 2005).

A. Stupas



Fig. 343. Stupa of Tokar Dara (Najigram). N side. (Spagnesi 2005).



Fig. 344. Stupa of Tokar Dara (Najigram). N side; detail. (Spagnesi 2005).

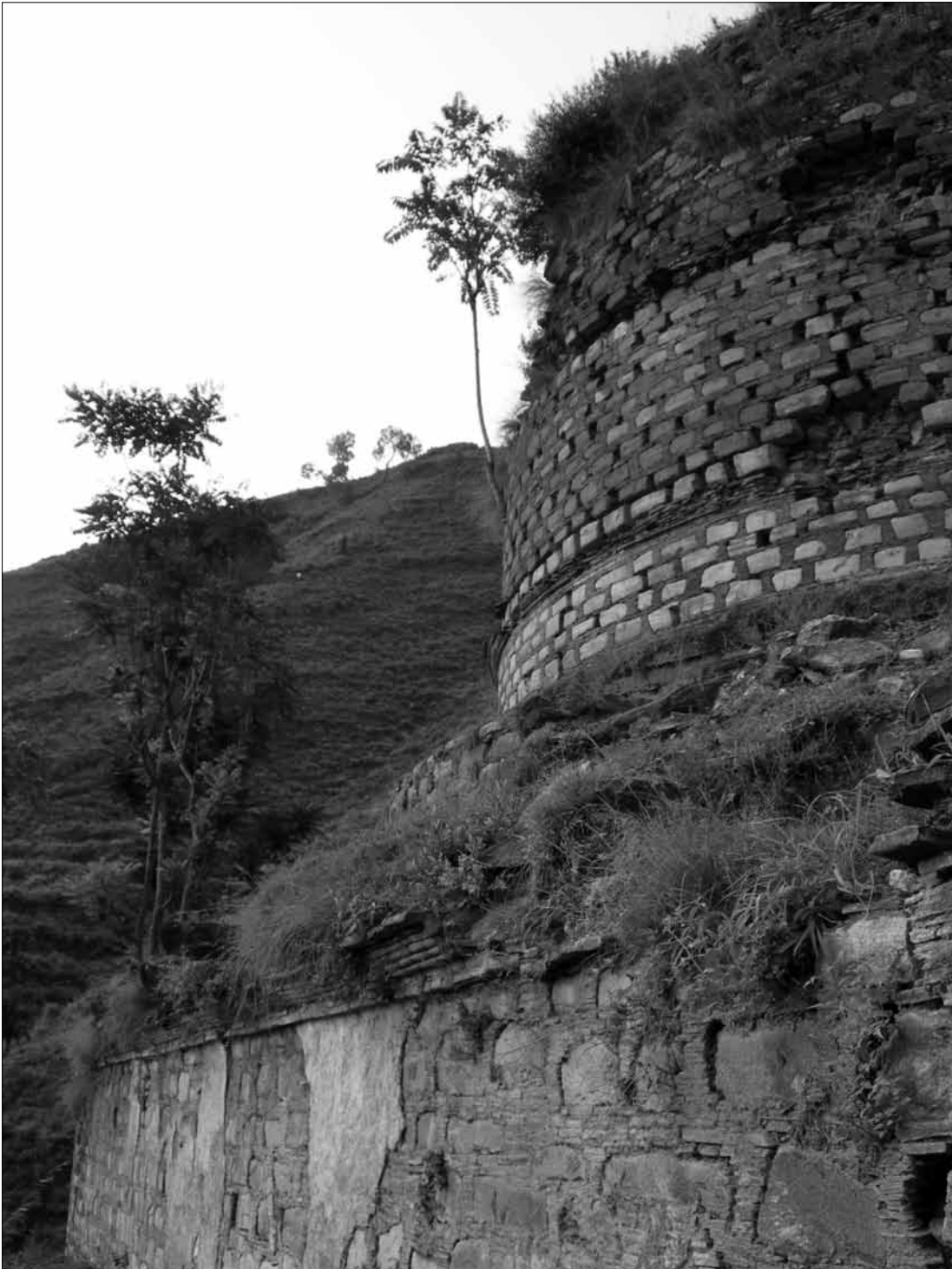

Fig. 345. Stupa of Tokar Dara (Najigram). N side; detail. (Spagnesi 2005).



Fig. 346. Stupa of Tokar Dara (Najigram). E side. (Spagnesi 2005).



Fig. 347. Stupa of Tokar Dara (Najigram). N (on the right) and E (on the left) corner. (Spagnesi 2005).



Fig. 348. Stupa of Tokar Dara (Najigram). S (on the left) and E (on the right) corner.
(Spagnesi 2005).



Fig. 349. Stupa of Tokar Dara (Najigram). N side, 1st, 2nd and 3rd storey showing visible stretches of the bases and cornices. (Spagnesi 2005).



Fig. 350. Stupa of Tokar Dara (Najigram). N side, 1st storey, cornice with brackets; detail. (Spagnesi 2005).



Fig. 351. Stupa of Tokar Dara (Najigram). N side, 1st storey, detail of a bracket. (Spagnesi 2005).

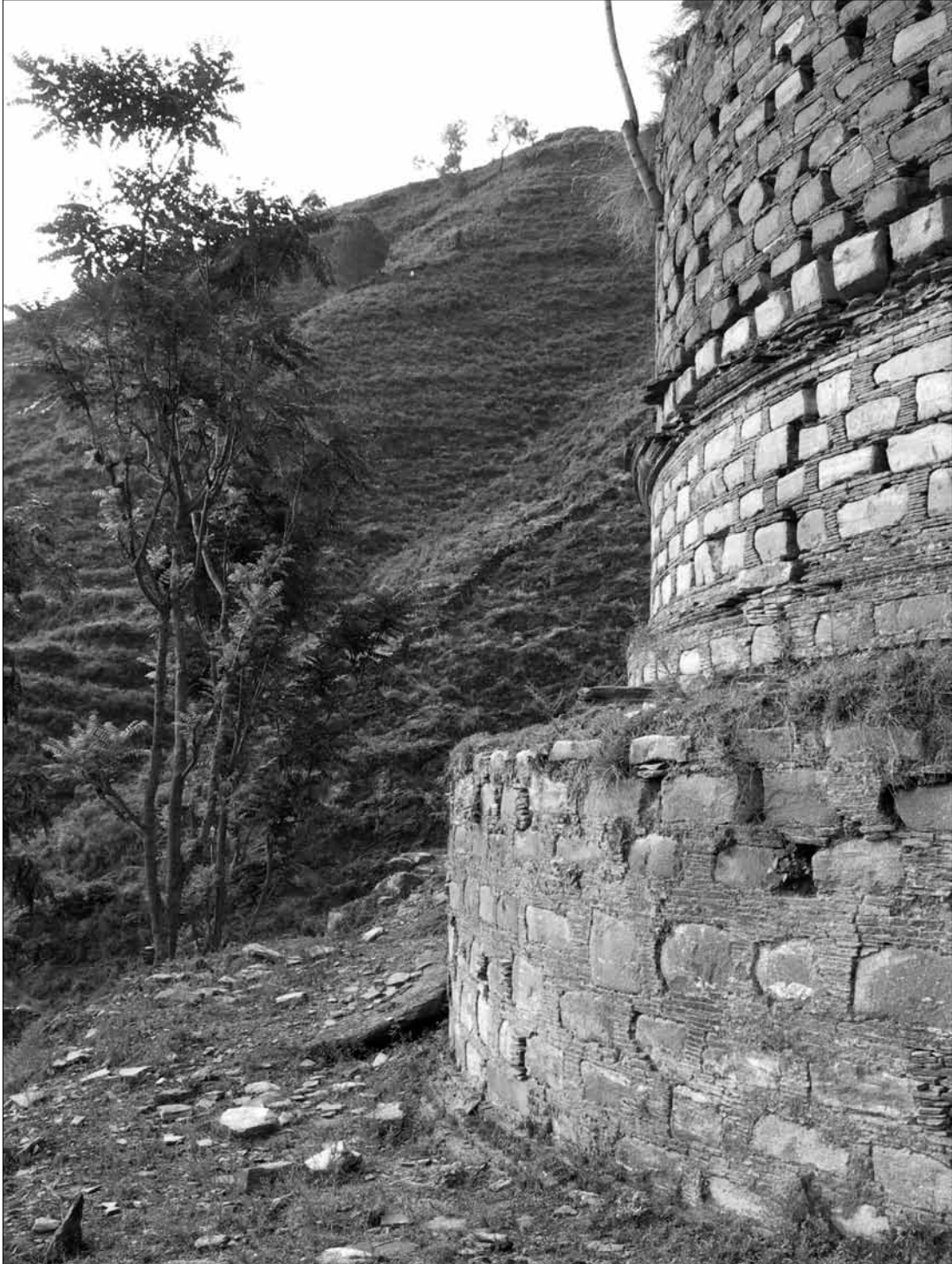

Fig. 352. Stupa of Tokar Dara (Najigram). N side, 2nd, 3rd and 4th storey, profile.
(Spagnesi 2005).



Fig. 353. Stupa of Tokar Dara (Najigram). N side, 3rd and 4th storey, with traces of plaster; profile. (Spagnesi 2005).



Fig. 354. Stupa of Tokar Dara (Najigram). W side, 2nd storey; stairway, projection, N side. (Nascari 1993).



Fig. 355. Stupa of Tokar Dara (Najigram). W side, 3rd storey, niche podium (?), front side. (Nascari 1993).



Fig. 356. Stupa of Tokar Dara (Najigram). W side, 3rd storey, cornice. (Nascari 1993).

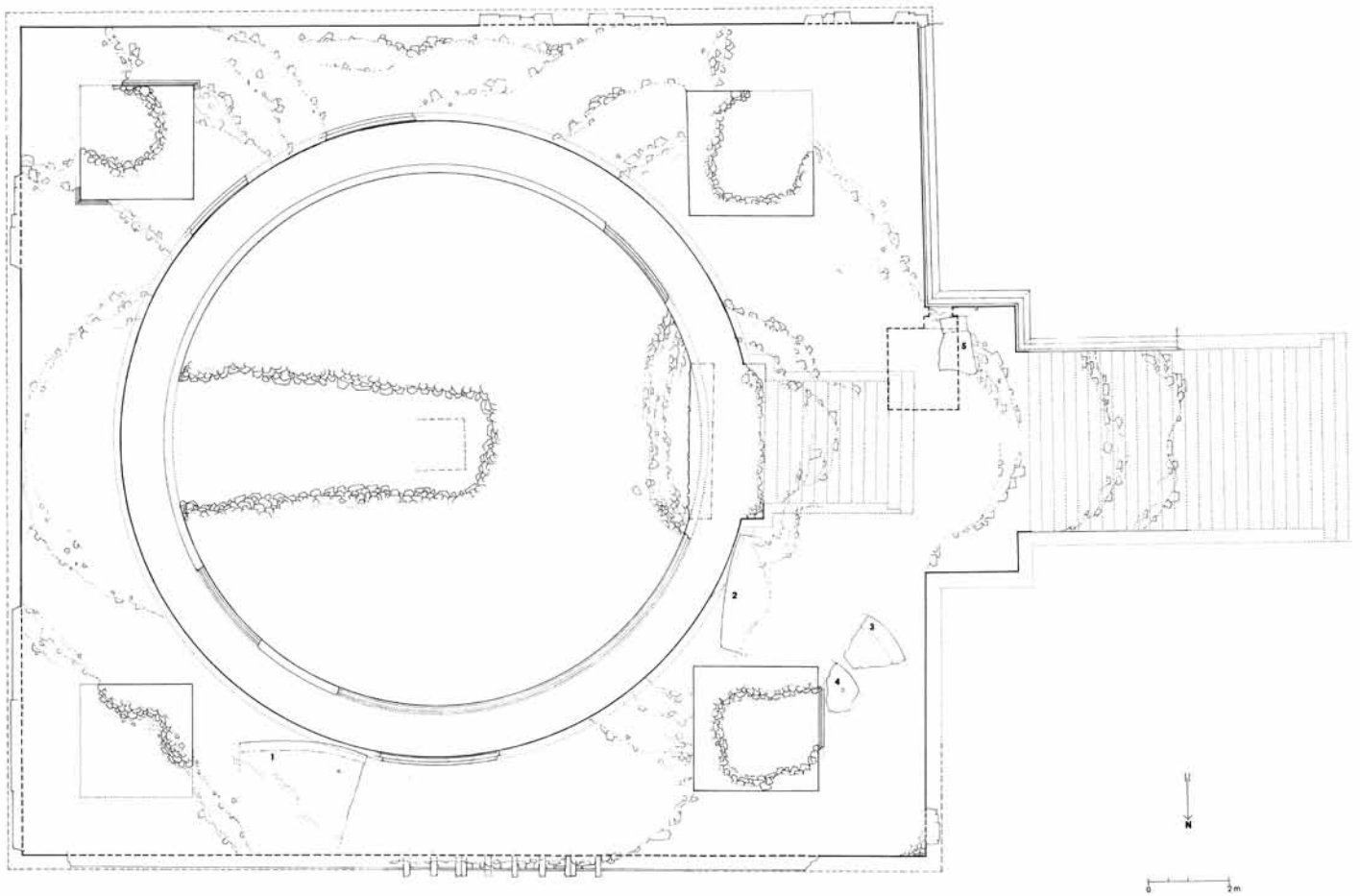

Fig. 357. Stupa of Tokar Dara (Najigram). Plan. (Spagnesi 2005; Martore 2006).

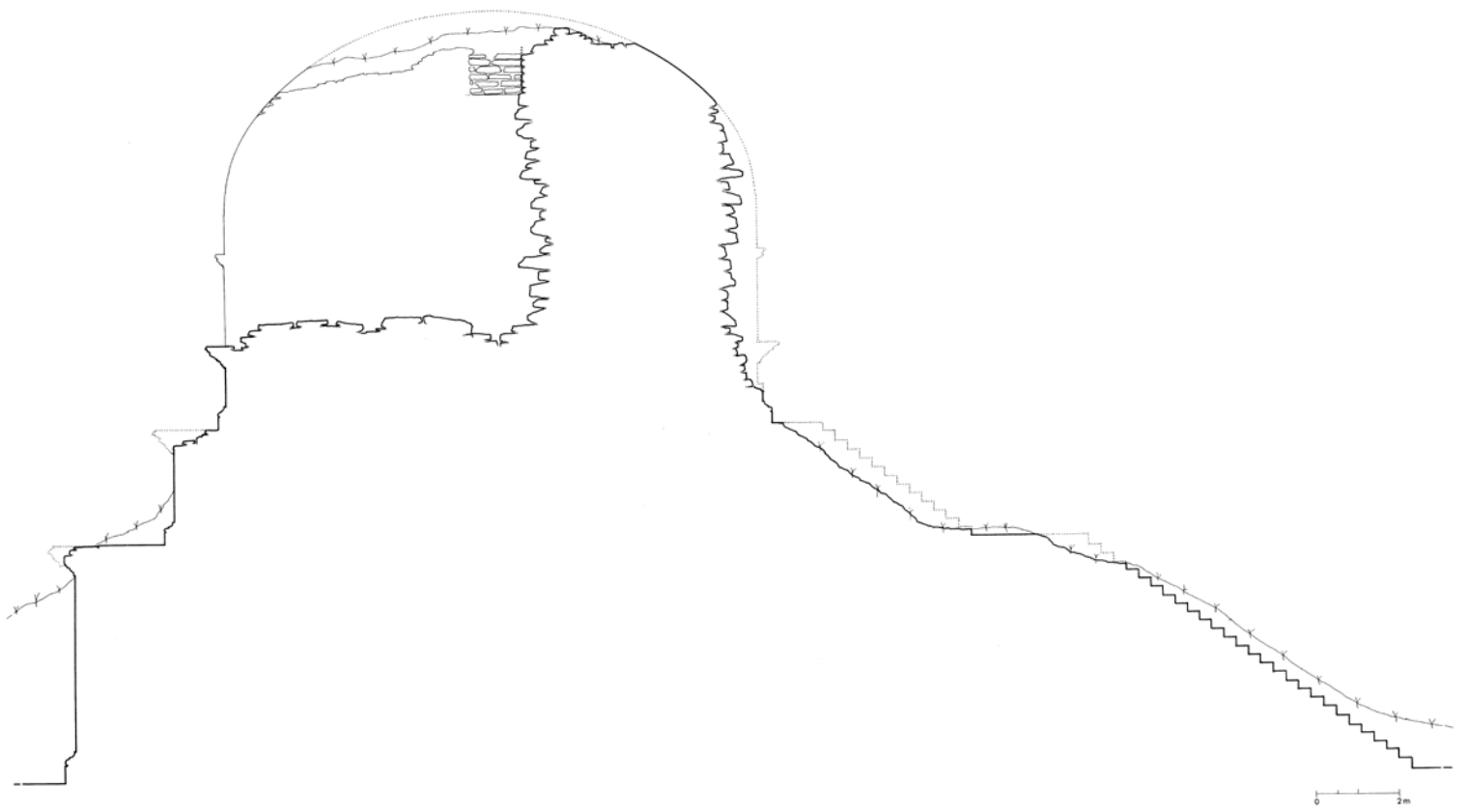

Fig. 358. Stupa of Tokar Dara (Najigram). E-W cross section. (Cimmino 1965; Martore 2003).

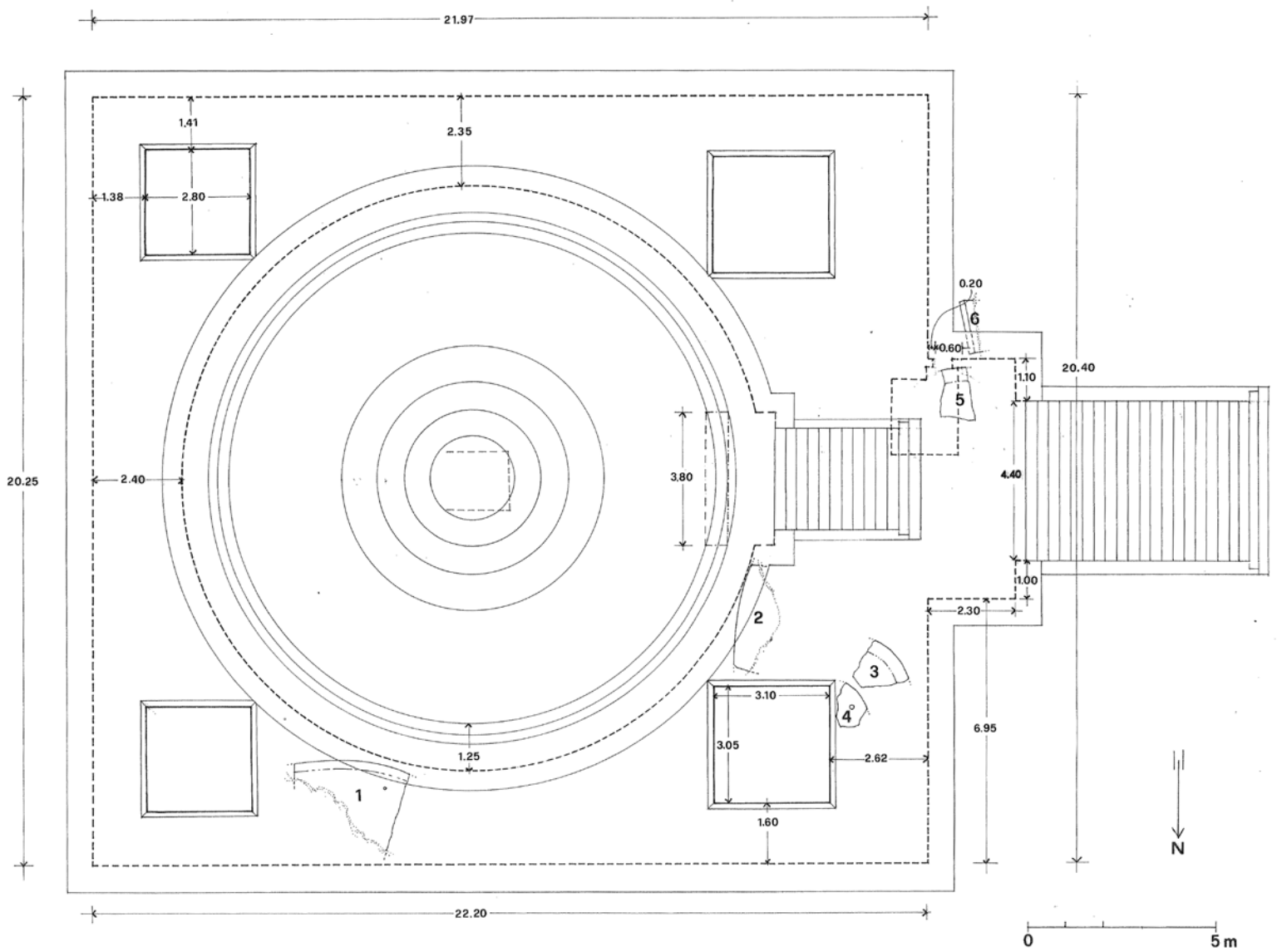

Fig. 359. Stupa of Tokar Dara (Najigram). Sketch plan showing the measures. (Martore 1986).

A. Stupas

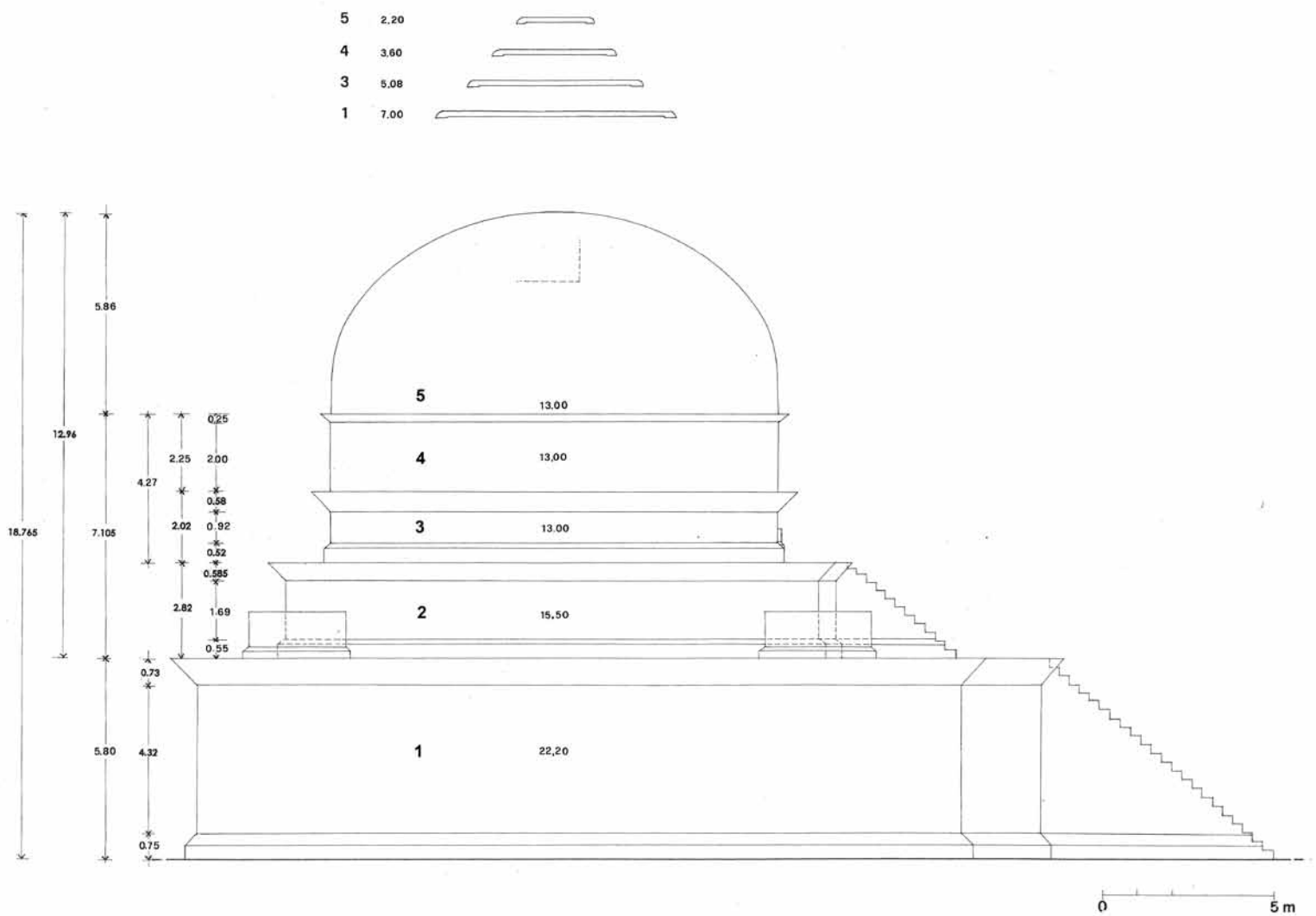

Fig. 360. Stupa of Tokar Dara (Najigram). Sketch elevation showing the measures. (Martore 1986).

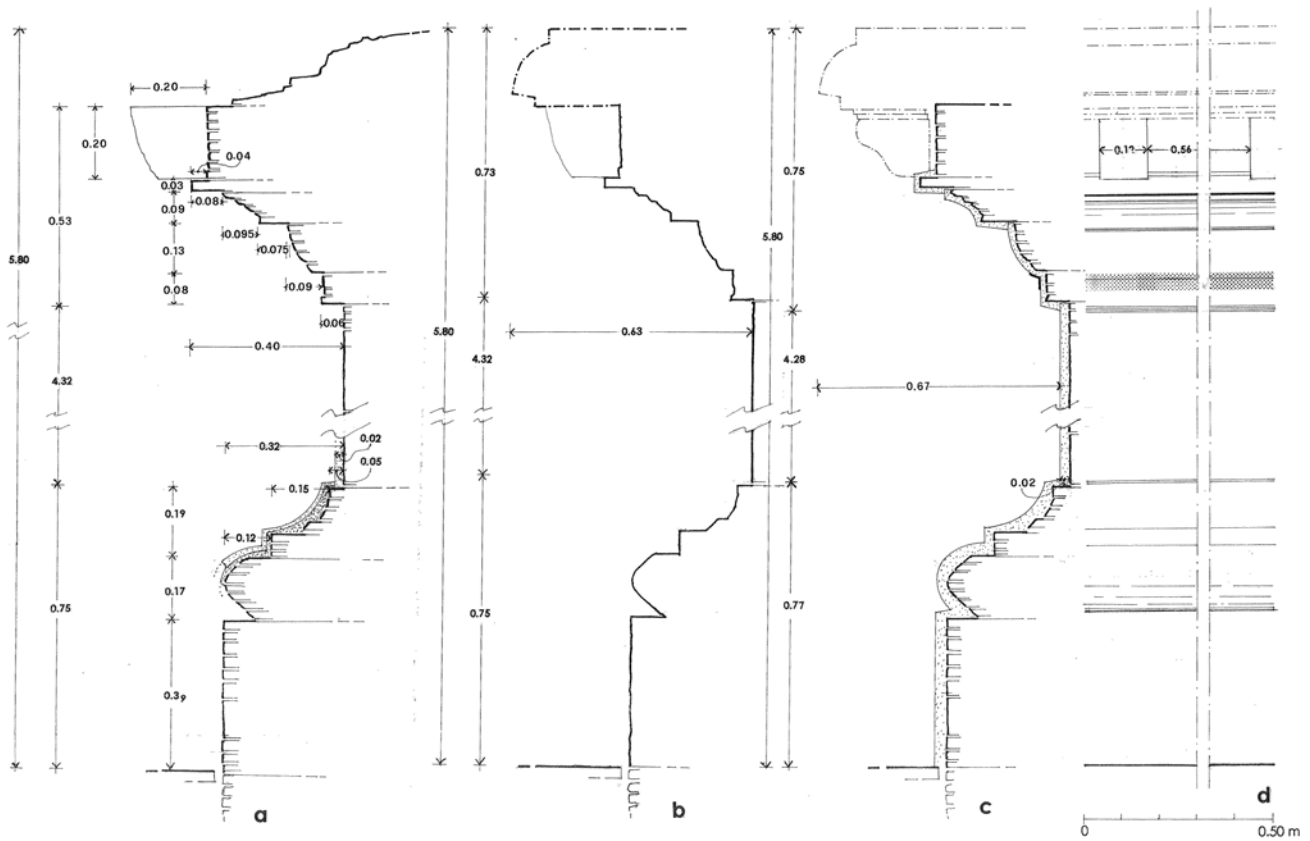

Fig. 361. Stupa of Tokar Dara (Najigram). 1st storey. *a.* profile. *b.* reconstructed profile, without plaster. *c.* reconstructed profile, with plaster. *d.* reconstructed elevation. (Martore 1986).

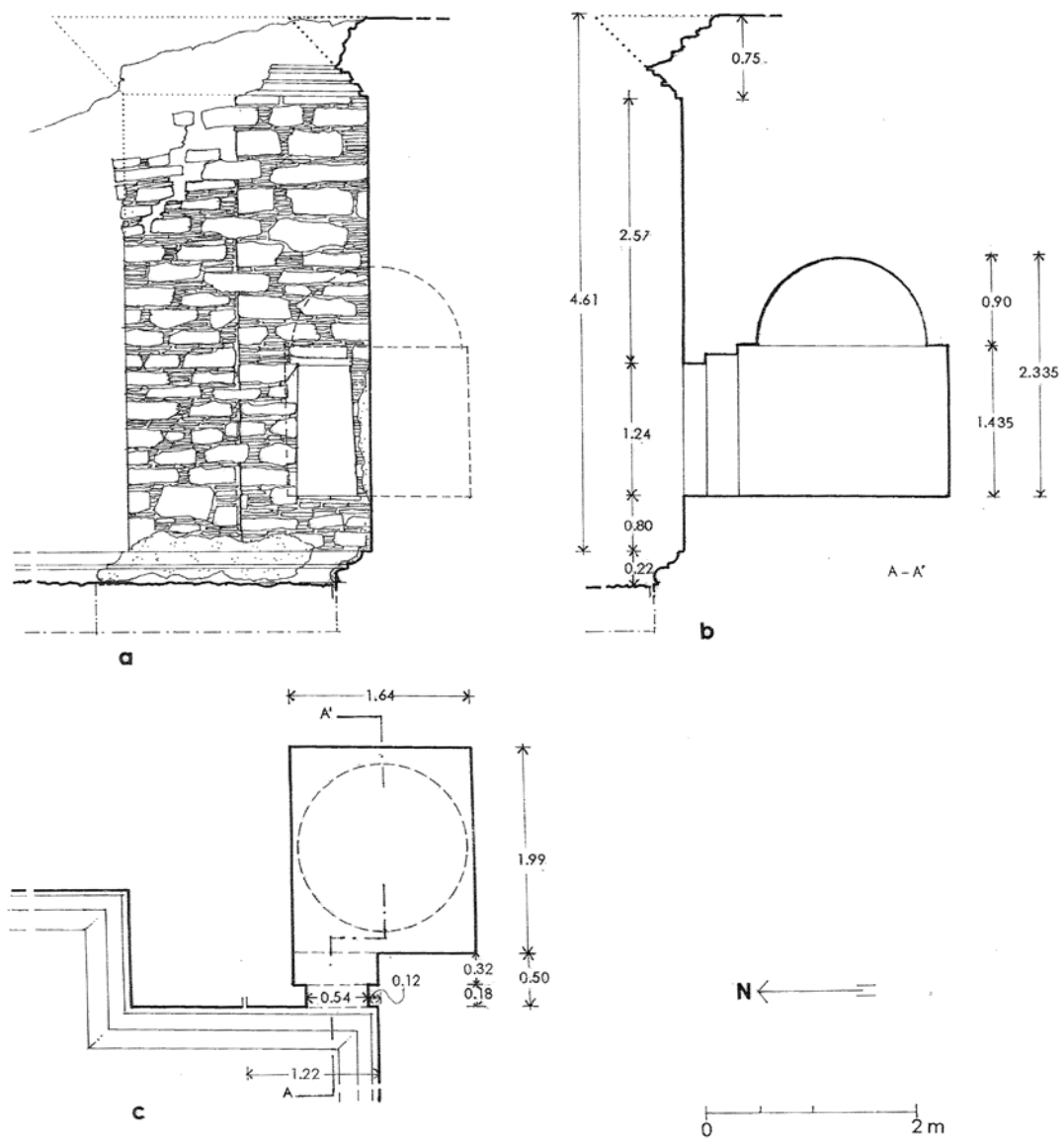

Fig. 362. Stupa of Tokar Dara (Najigram). 1st storey. Room inside the stairway projection; S side. *a.* elevation. *b.* A-A1 cross section. *c.* plan. (Spagnesi 2005; Martore 2005).

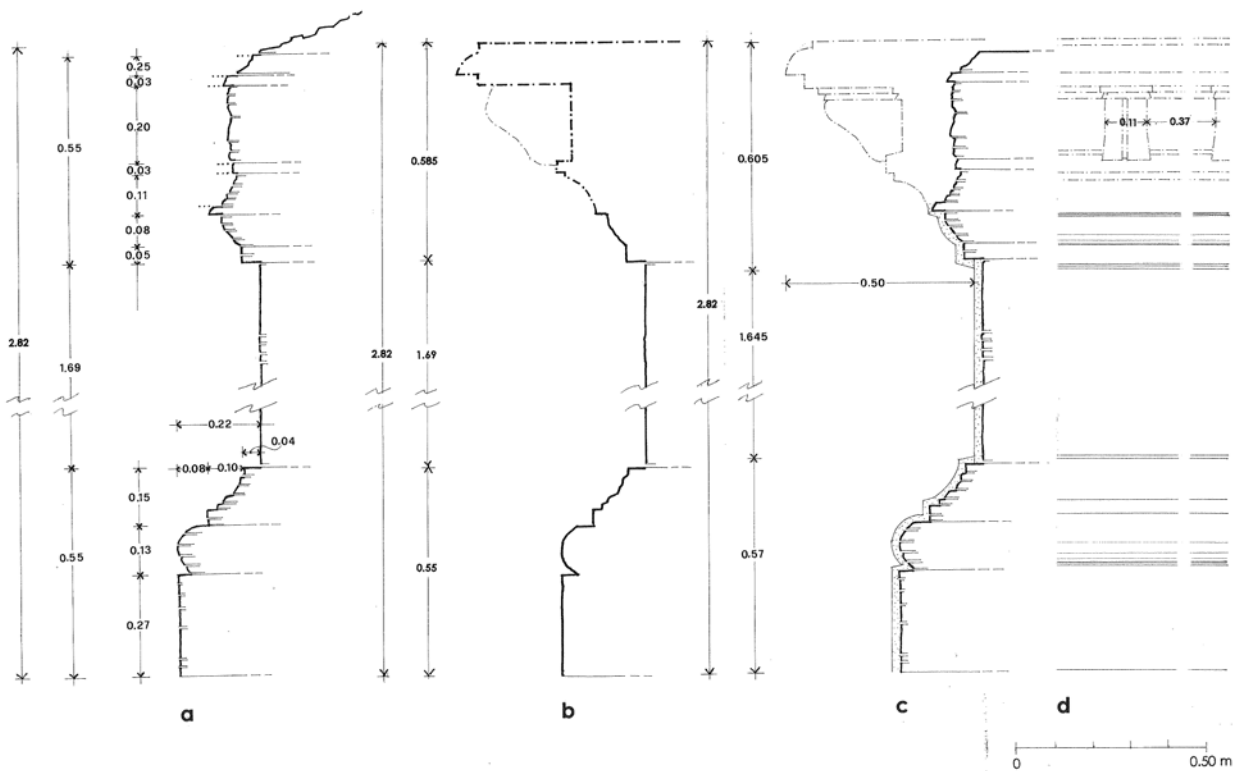

Fig. 363. Stupa of Tokar Dara (Najigram). 2nd storey. *a.* profile. *b.* reconstructed profile, without plaster. *c.* reconstructed profile, with plaster. *d.* reconstructed elevation. (Martore 1986).

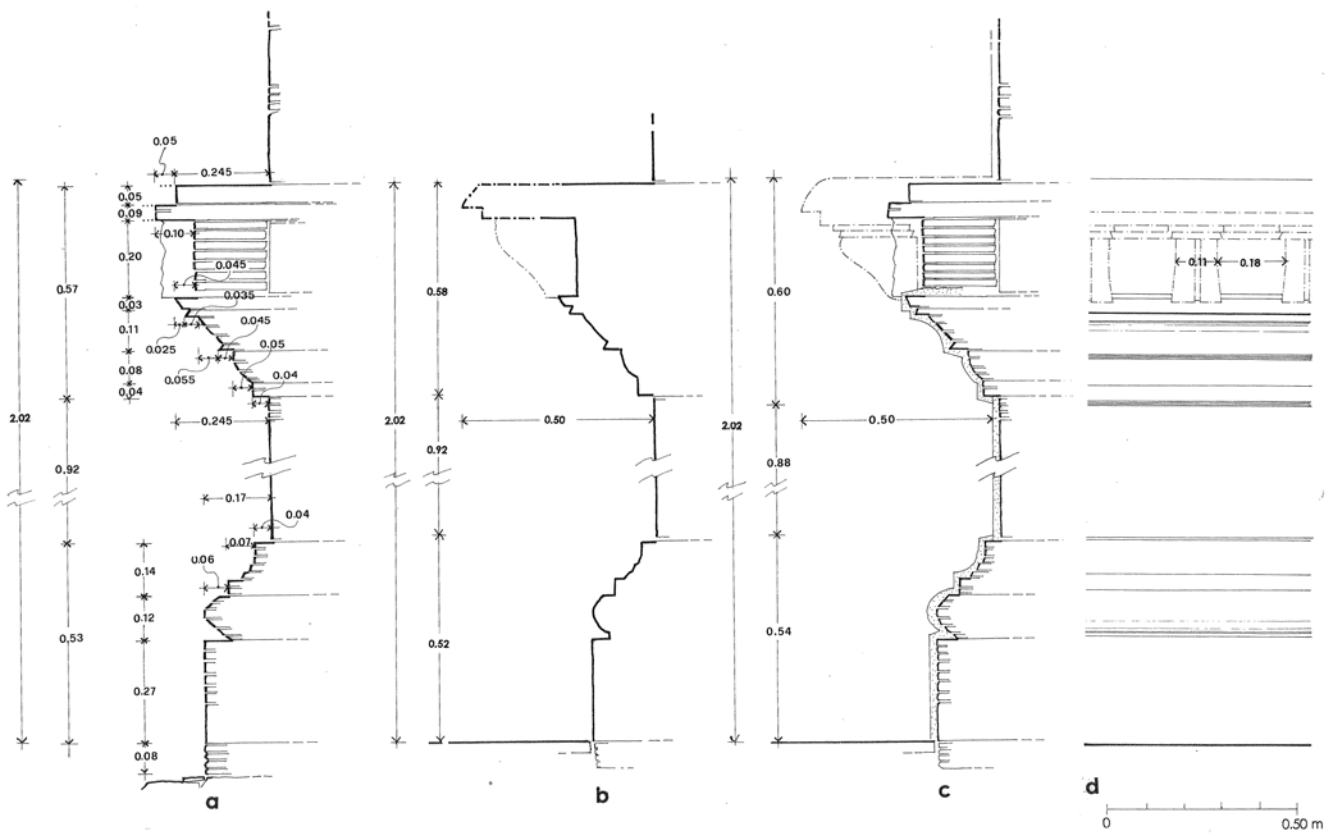

Fig. 364. Stupa of Tokar Dara (Najigram). 3rd storey. *a.* profile. *b.* reconstructed profile, without plaster. *c.* reconstructed profile, with plaster. *d.* reconstructed elevation. (Martore 1986).

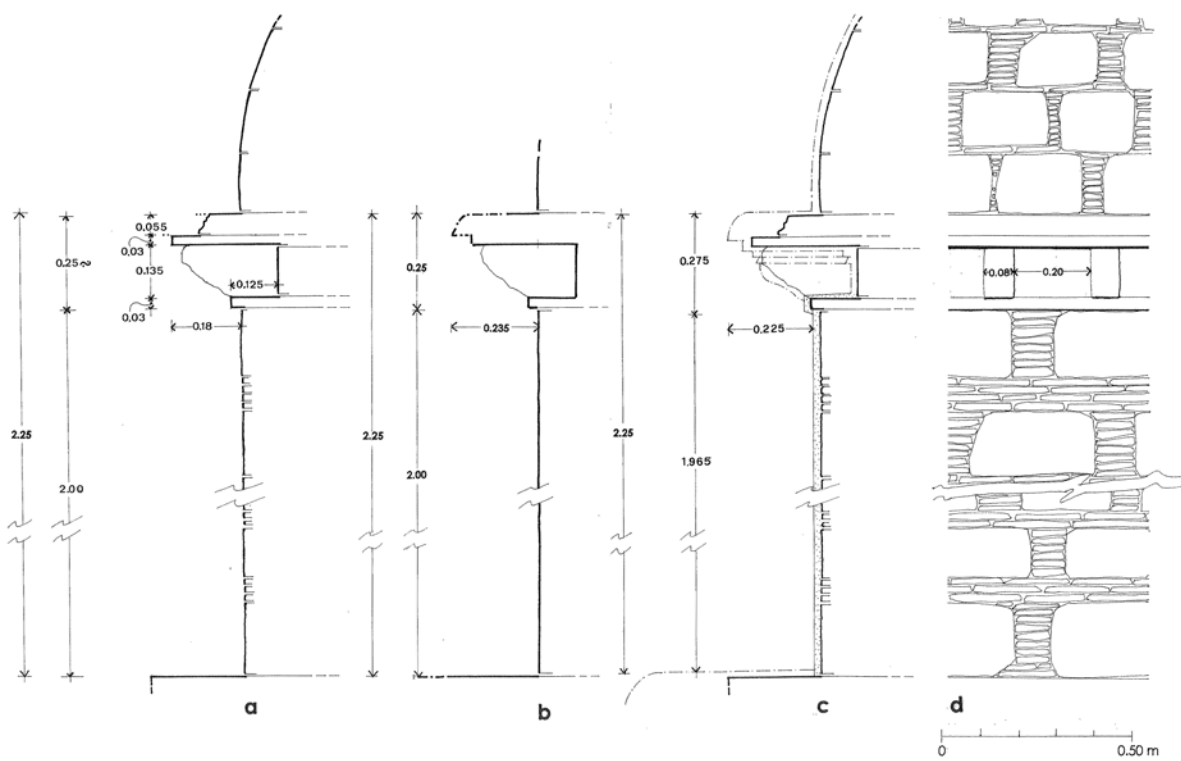

Fig. 365. Stupa of Tokar Dara (Najigram). 4th (drum) and 5th (cupola) storey. *a.* profile. *b.* reconstructed profile, without plaster. *c.* reconstructed profile, with plaster. *d.* reconstructed elevation. (Martore 1986).

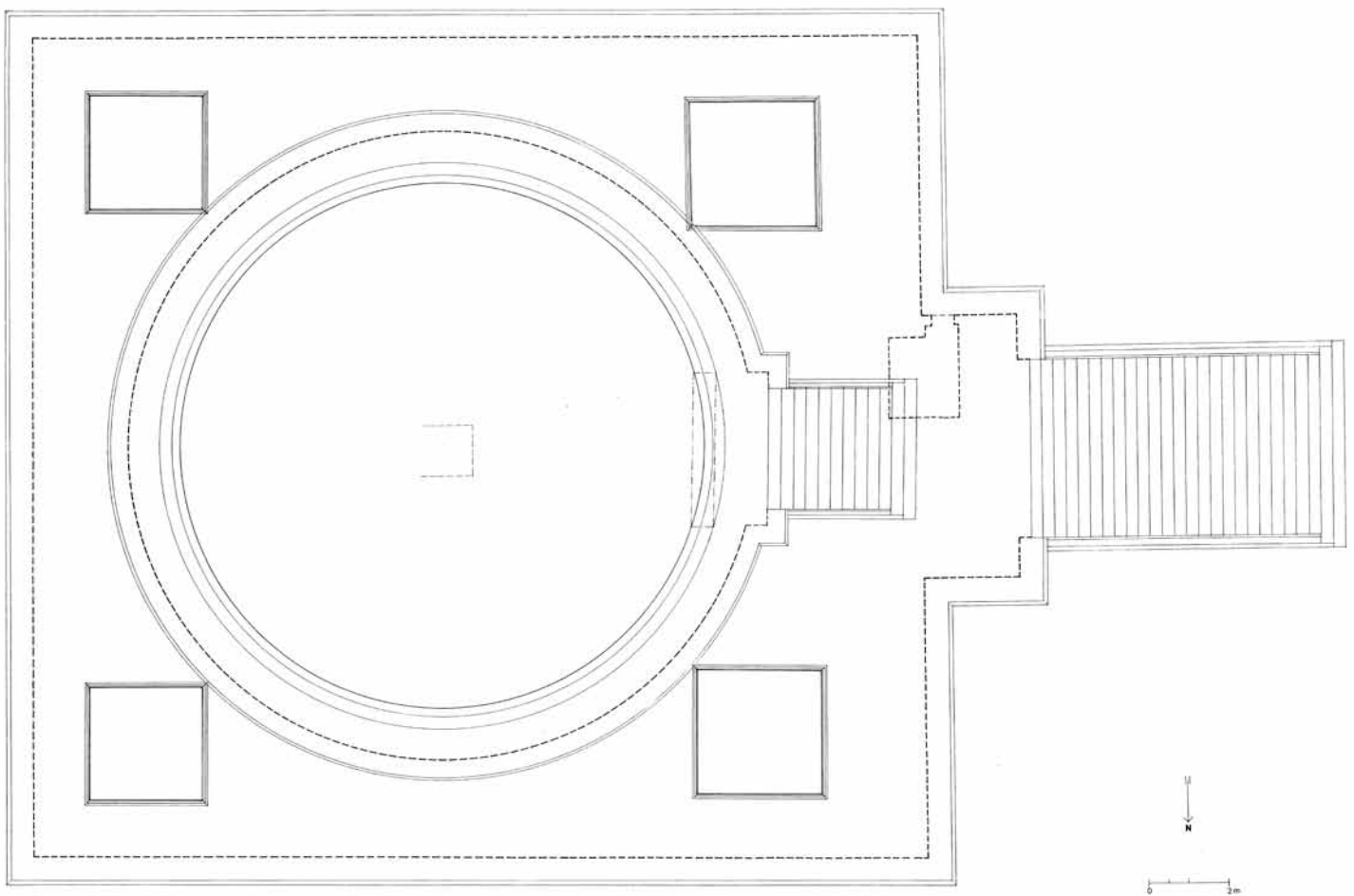

Fig. 366. Stupa of Tokar Dara (Najigram). Reconstructed plan. (Martore 2003).

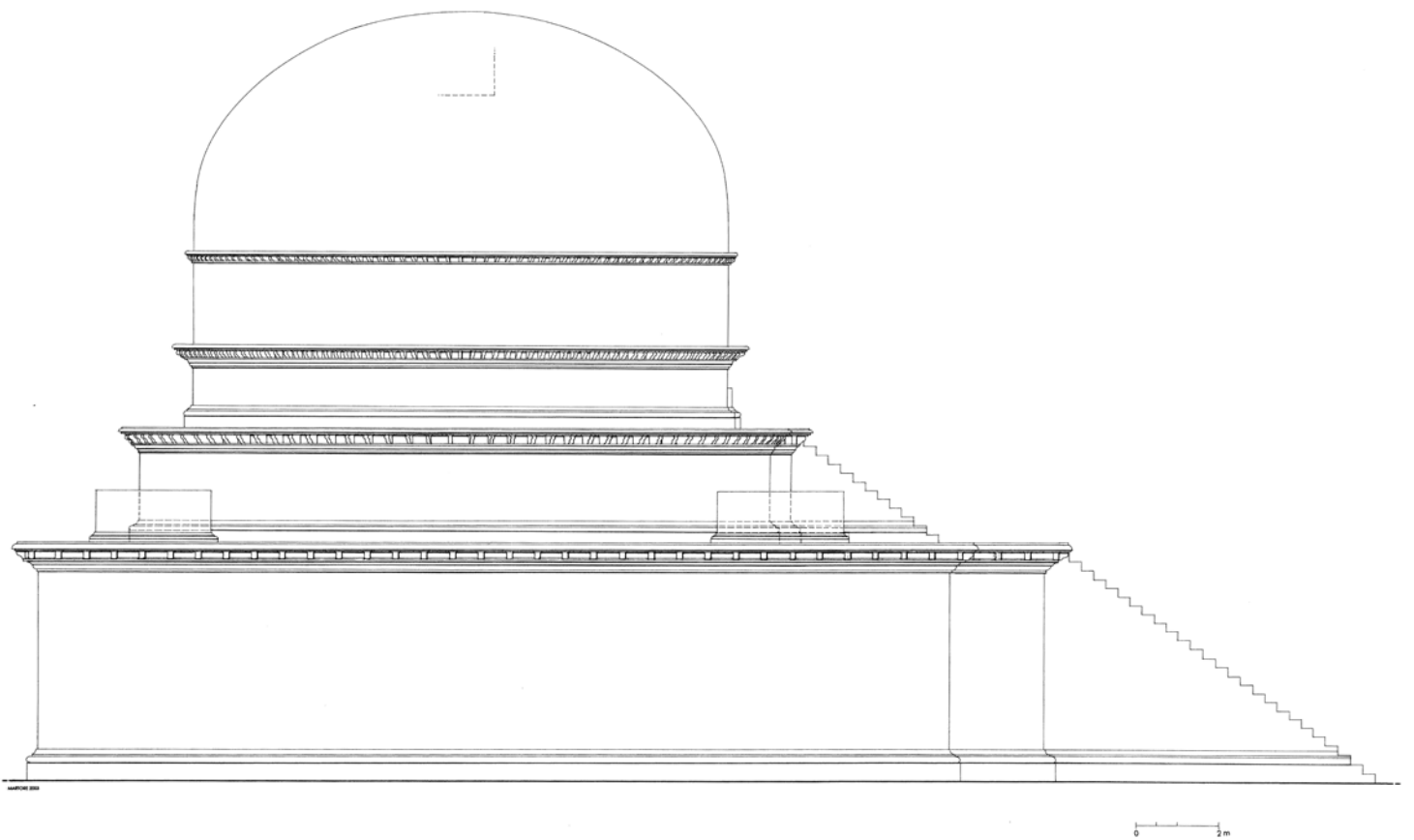

Fig. 367. Stupa of Tokar Dara (Najigram). Reconstructed elevation. (Martore 2003).

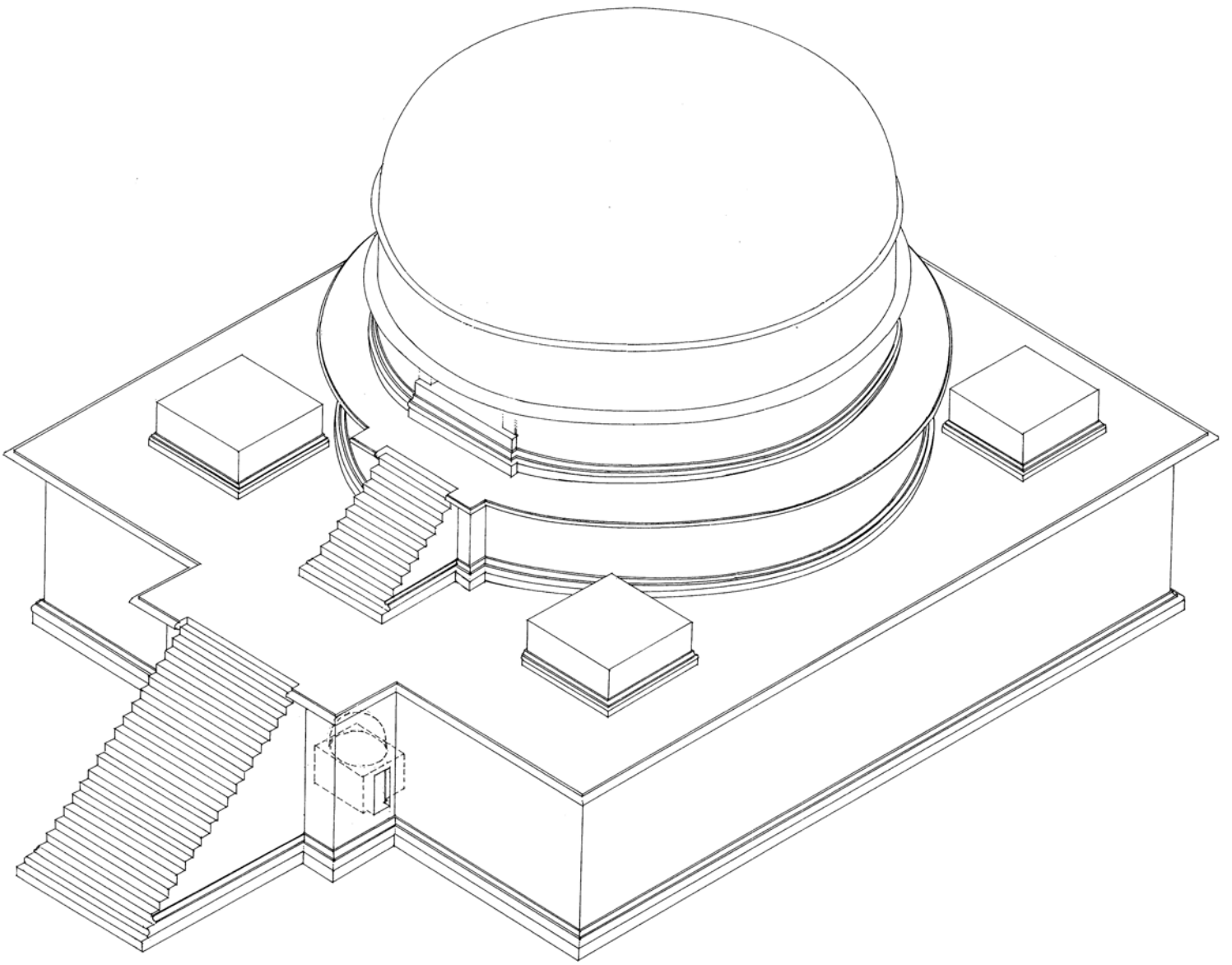

Fig. 368. Stupa of Tokar Dara (Najigram). Axonometric view. (Martore 2003).

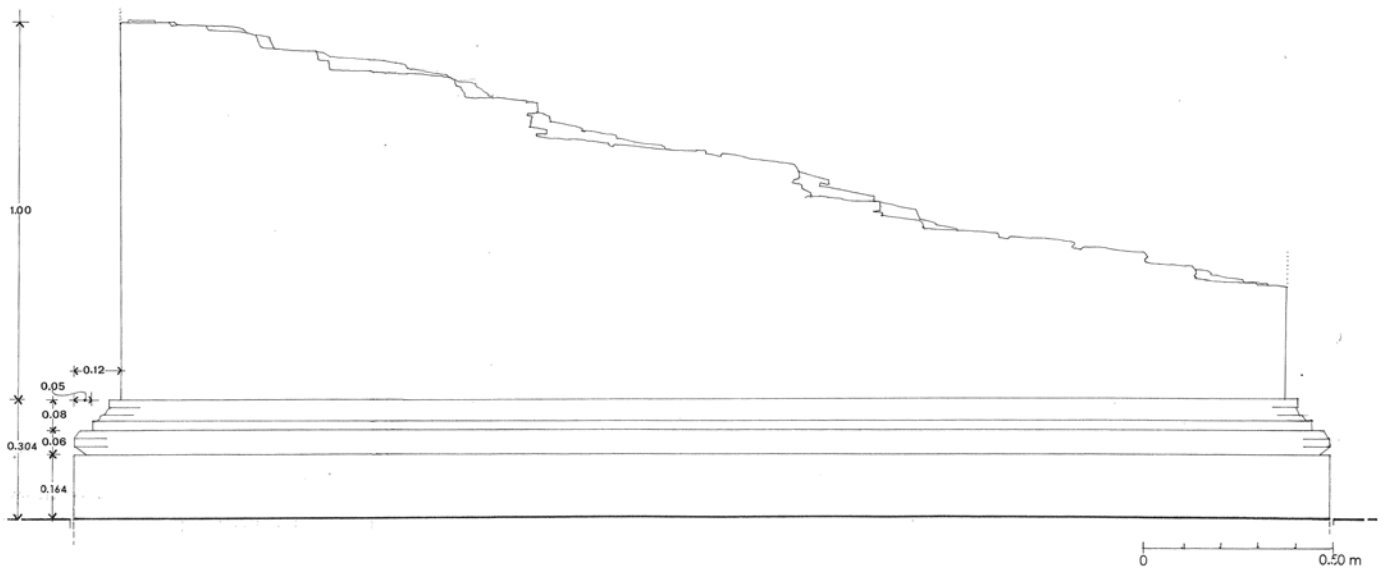

Fig. 369. Stupa of Tokar Dara (Najigram). NW column; pedestal; elevation. (Martore 2003).

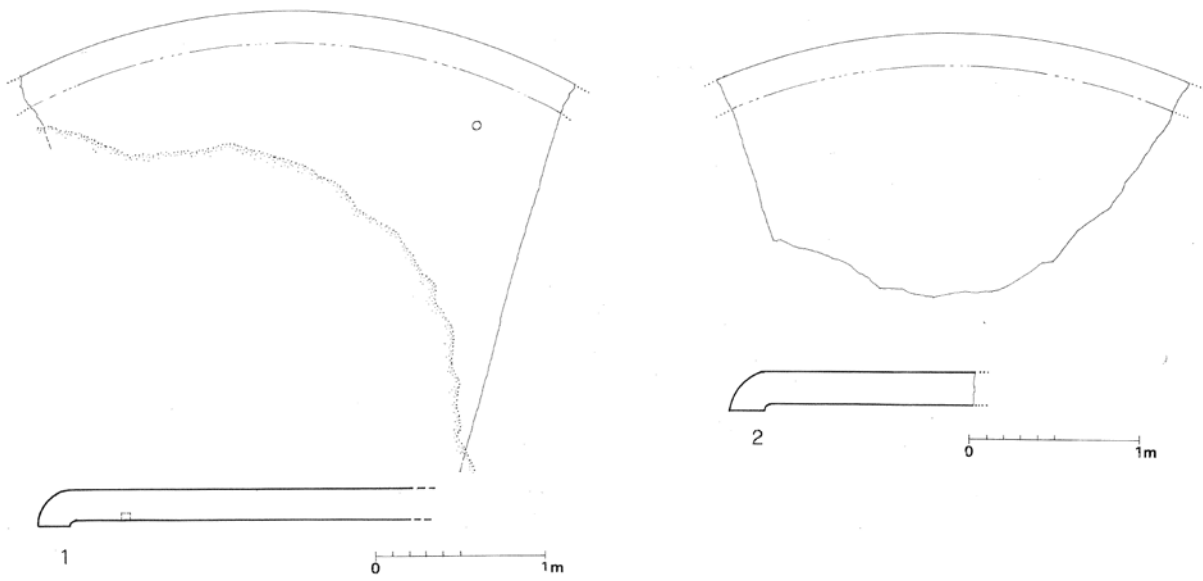

Fig. 370. Stupa of Tokar Dara (Najigram). Chattravali elements, on the upper floor of the 1st storey; nos. 1-2. (Martore 2003).

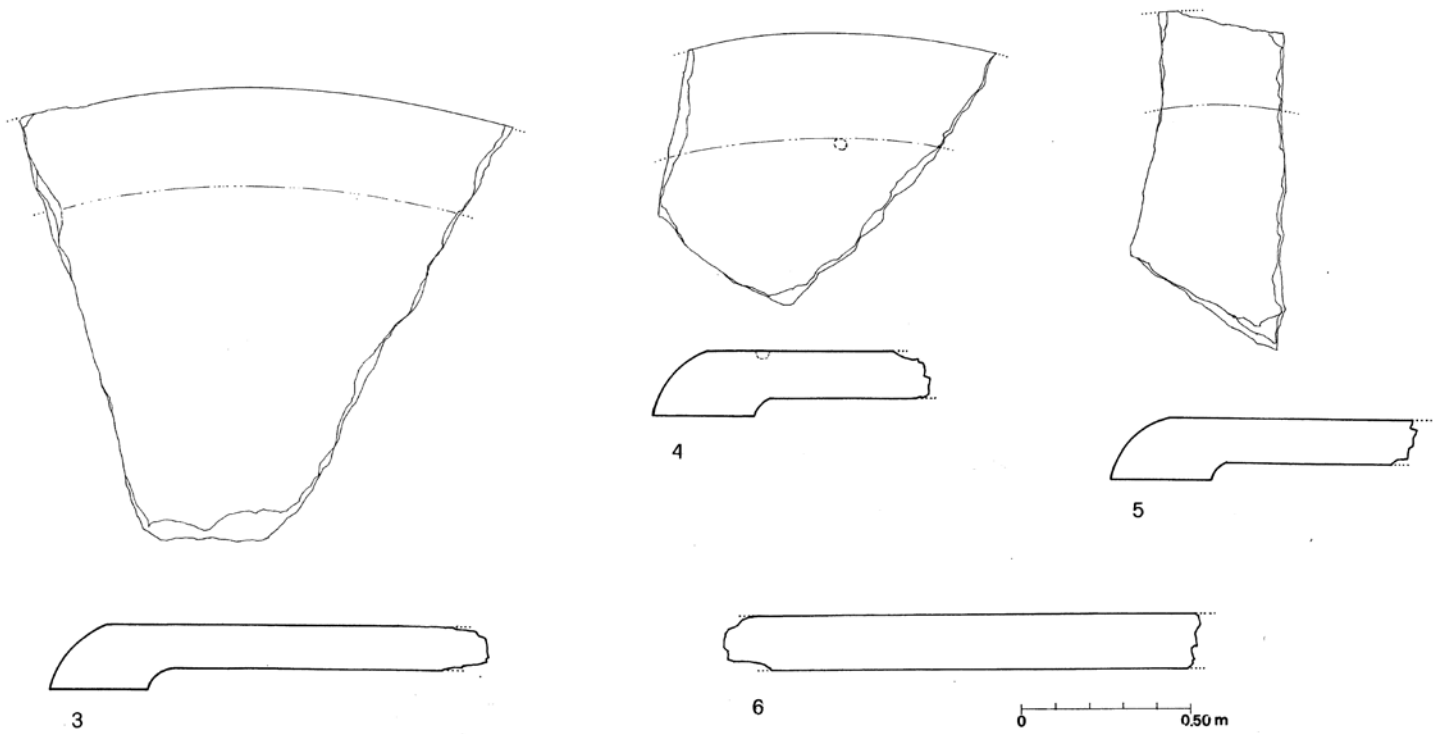

Fig. 371. Stupa of Tokar Dara (Najigram). Chattravali elements, on the upper floor of the 1st storey; nos. 3-5; no. 6 probably belongs to a harmika. (Martore 2003).

A12. The stupas of Barikot

(Figs. 372-381)

The Site

Zone of Barikot.

Position: Lat. 34° 40' N; Long. 72° 13' E; SPM 43 B/2.

The eastern part of Barikot is the focus of roads, valleys and watercourses. Starting from the S we visited the Kandak valley, and then the Najigram valley, the road through the Karakar pass and lastly the Amluk Dara valley. At the point where these valleys and roads converge, opening up toward the central Swat Valley with its river, stood the remains of two large stupas. The stupas no longer exist, having been destroyed or reduced to a heap of ruins during the expansion of the town of Barikot. They were situated at the beginning of the road leading to the Karakar pass, on the right hand side, at the foot of the N spurs of the Sur-ghar, the mountain chain that separates the Karakar valley from the Kandak valley; the area is designated as Barikot Gumbatuna.

Bibliography and Documentation

They were mentioned by Stein 1929: 31, fig. 10⁽¹⁾; he accompanies his description (1930: 12, fig. 2, pl. 2 below) with a photo and a sketch of them⁽²⁾. They must

⁽¹⁾ 'When I proceeded up Kandag, the westernmost of those valleys, I found first a pair of large but ruinous Stūpas within easy reach of Bīr-koṭ (fig. 10). The size of the bases, from sixty to seventy feet square, and the conspicuous position they occupied made it possible to reconstruct in imagination the imposing appearance that these structures once presented. But in addition to successive diggings for 'treasure' it was clear that quarrying operations for building stones had proceeded here for ages, while during more recent times search for sculptural remains had helped to complete the havoc'.

⁽²⁾ 'Following the general direction of my journey we may first visit the westernmost of those valleys, known as *Kandag* from one of its principal villages. Where it opens out towards the hill of Bīr-koṭ there rises a pair of large but much injured Stūpas (fig. 2) at the foot of a small ridge. This is the last offshoot of the spur which divides the Kandag valley from that of Najigrām, the next eastwards. The Stūpas are situated at a distance of three quarters of a mile from Bīr-koṭ village. They stand within about 57 yards of each other and

be identified on his map by the symbol of the stupa, situated at the mouth of the Kandak valley, to the left of the itinerary he followed when climbing as far as the Gumbat vihara. In pl. 2 the N Stupa is indicated as B, the S one as A; this indication was maintained in our description. In the photo in fig. 2, taken from the SW, stupa A is in the foreground; this photo, enlarged, is repeated in Stein (1929: fig. 10). The two stupas were situated about three quarters of a mile from Barikot, which was a small cluster of dwellings at the time, and were about 57 yards apart.

They were not mentioned by Barger & Wright (1941: 18).

They are referred to in the Tucci's description of the area (1958: 296-97) ⁽³⁾.

Reconnaissance by Taddei 1959, Scerrato 1959, Faccenna and Caroli (1959) with notes and photographs; no graphic surveys were carried out. The following description is based on Faccenna's notes.

Reconnaissance by Olivieri 1992, who observed them in a state of severe degradation.

In the reconnaissance carried out by Faccenna in 1993 the stupas were observed to have been destroyed, reduced to an indistinct pile of ruins ⁽⁴⁾. The site was included in the Archaeological Map of the Swat Valley (Olivieri & Vidale 2006: 101) and designated as Gumbatuna 1.

as the sketch plans, pl. 2, show, have structurally much in common. Both have suffered far too much from quarrying operations for building stones and successive diggings for "treasure" to permit all dimensions to be determined with any approach to accuracy. But in the case of both it was possible to make out that in addition to the two usual circular upper bases and a lower square one there was a large terrace below, close on 70 feet square, supporting each Stūpa. The southern one [Stupa A] still retained in places the stone facing of the dome; this made it possible to ascertain its diameter as measuring approximately 26 feet. Its height including the drum could not have been less than 24 feet. The northern Stūpa [Stupa B] which had been damaged even more appears to have carried a dome only about 20 feet in diameter, while its proper square base showed the unusually great height of 16 feet. Along its foot there were indications of recent diggings for sculpture. These were ascribed to the same men who had been employed in rifling the ruined shrine close to Nal village. Among the débris at the foot of the Stūpa lay a massive stone slab, 3 feet 4 inches square and 6 inches thick. As shown by a hole in the centre, it had evidently once been fixed between the top of the dome and the succession of "Chhatras" surmounting it'.

⁽³⁾ '[...] the very extensive plain is dominated on the East by two big stūpas, greatly damaged, and on the West by the Barikot Gundeī which towers abruptly on the Swat river [...]; they [the walls] can easily be seen scattered all over a large area as far as the two stūpas on the spur dividing the Najigram and the Kandak valleys. There is no doubt that we are in front of an archaeological site of the greatest interest and a place formerly thickly populated. [...] This fact was noted by Stein and perhaps induced Barger and Wright to make Barikot the centre of their investigations, which were unfortunately carried out in such a haphazard way that no positive result can be drawn from them'.

⁽⁴⁾ That is how they are recalled by Khan M. Ashraf (1993: 59, pl. XIII, fig. 45 [from Stein 1930: fig. 2]): 'Two stupas were surveyed by Stein in 1926 on the spur dividing the valleys of Najigram and Kandak, opposite the Bir-kot hill. Their domes measure respectively 8.00 and 6.00 m. They were still recognizable in 1955 when Prof. Tucci visited Swat, but no trace is now left of them'.

The Stupas

Stupa A

‘Lo stupa più a monte è il più conservato dei due (1959). La parte inf. è coperta dal cumulo dei detriti di crollo. Da esso emerge il nucleo degli ultimi due corpi cilindrici sup. e della cupola. Sul lato NE si conserva una breve porzione del paramento, in corrispondenza della parte sup. del corpo di raccordo della cupola composita e dell’inizio della medesima cupola rialzata. La linea di separazione tra le due parti è marcata da fila di lastre (ne resta una soltanto) aggettanti dall’incasso continuo, riempito; lastra: aggetto 0.12, parte inserita 0.22, spess. 0.05’ ⁽⁵⁾.

The conserved part of the transition storey, which lacks the base resting on the storey below (drum), measures c. 0.90 and has a slightly re-entrant profile towards the top. The dome itself begins in a vertical direction before turning into a probably hemispheric line (raised dome).

The facing consists of dressed blocks (average h. 0.12-0.16, leng. 0.28-0.30), arranged in relatively regular rows connected by a texture of thin schist slabs. The core is composed of carefully arranged material of varying nature and closely connected consisting of blocks, large and small slabs and chips produced by the construction process. It is perforated in the centre, starting from the top of the dome.

Stein notes the presence of a large terrace (c. 70 feet square) supporting the stupa with its first quadrangular shaped storey; the diameter of the dome may be calculated as c. 26 ft. with a height, including the storey below, of 24 ft.

The description of the remaining storeys defines the typology of a composite dome.

From the lower circular shaped storey, the drum, springs the transition storey, with no base, with a wall slightly re-entrant below the row of projecting slabs. This marks the beginning of the raised dome which rises first vertically and then curves.

⁽⁵⁾ The stupa further uphill is the better conserved of the two (1959). The lower part is covered by the pile of detritus left by the collaps. From it emerges the core of the last two upper cylindrical storeys and the dome. On the NE side a short section of the facing is conserved corresponding to the upper part of the transition storey of the composite dome and of the beginning of the raised dome itself. The separation between the two parts is marked by a row of slabs (only one is left) projecting from the continuous, filled in cavity; slab: projection 0.12, inserted part 0.22, thickn. 0.05’.

This interesting and important element of the structure was found for the first time in this monument, thus explaining the continuous socket that elsewhere was always found to be empty.

Stupa B

‘Collocato a N di A, meno conservato di questo, ne resta, emergente dal cumulo circostante di crollo, soltanto il nucleo della struttura sup., in cui si possono riconoscere i due corpi cilindrici sup. e la cupola fortemente corrosa. Il nucleo ha tessitura uguale al precedente monumento; è forato dall’alto.

‘Come in A lo Stein nota la presenza di una larga terrazza di uguale misura, su cui si impostava lo stupa con il proprio corpo quadrangolare, alto 16 ft. (“unusually great height”), mentre la cupola era “only” di ca. 20 ft. di diametro’ (6).

The two stupas must have stood on two terraces situated at different heights in a southward direction. They may be considered part of a considerably large area arranged into two terraces and surrounded by numerous smaller stupas.

The two stupas probably displayed the same construction characteristics and belonged to the same complex.

Faccenna (1959) further notes: ‘Poco distante, a SW, sono tracce di un mound con resti di un piccolo stupa, forato’ (7).

⁽⁶⁾ ‘Situating N of A, less well conserved than the latter, all that emerges from the surrounding pile of debris is the core of the upper structure, which may be identified as the two upper cylindrical plan storeys and the badly corroded dome. The core has the same texture as the preceding monument; it is perforated from the top.

‘As in A Stein notes the presence of a large terrace of the same size supporting the stupa with its own quadrangular shaped storey, 16 ft. high (‘unusually great height’), while the dome was ‘only’ c. 20 ft. in diameter’.

⁽⁷⁾ ‘A short distance away, to the SW, lie traces of a mound with the remains of a small, perforated stupa’.

A. Stupas



Fig. 372. Barikot, Stupa A and B. General view from S to N. In the foreground, Stupa A; in the background, Stupa B. (After Stein 1930: fig. 2 [=1929: fig. 10]).

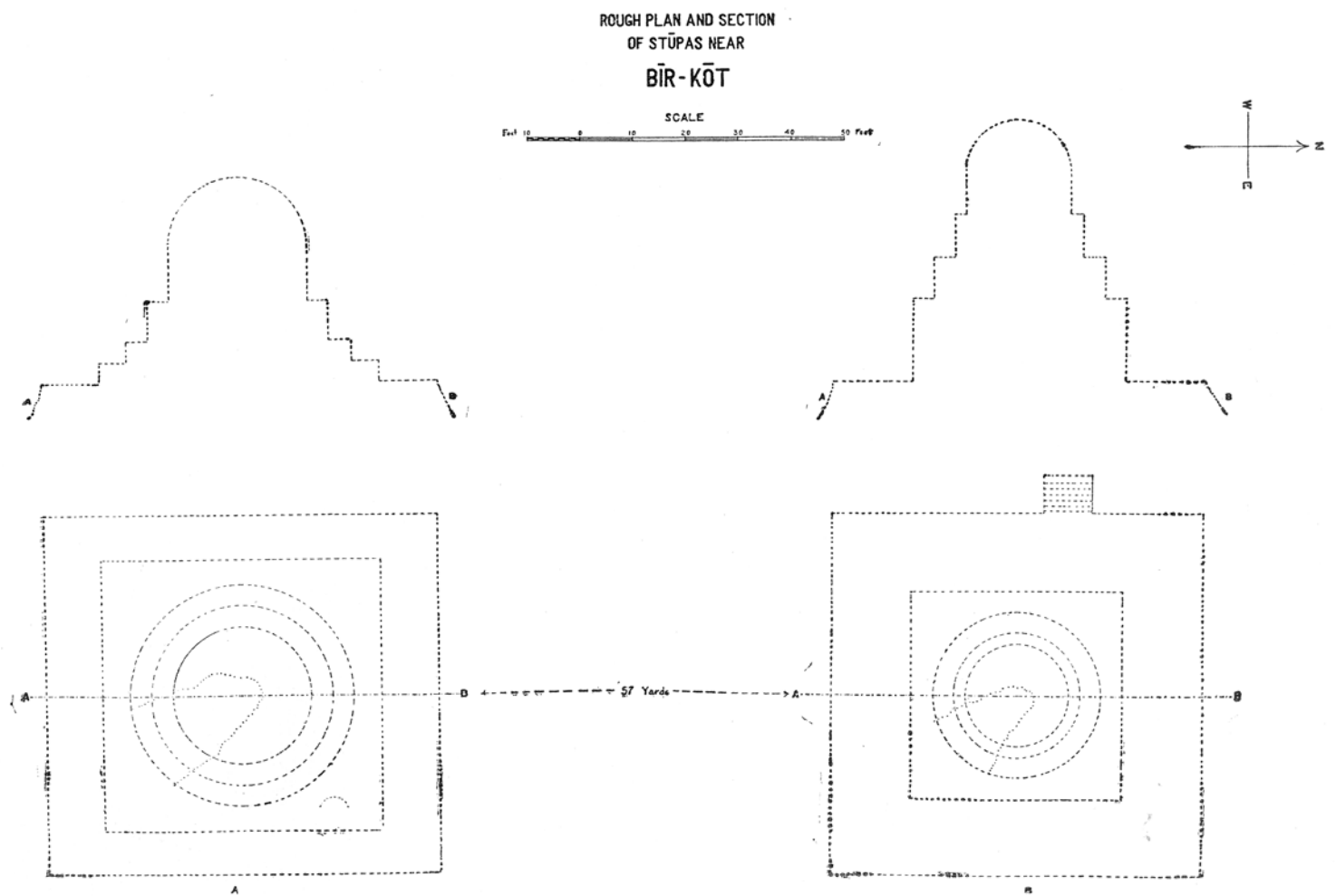

Fig. 373. Barikot, Stupa A and B. Sketch plan and elevation. (After Stein 1930: pl. 2, at the bottom).



Fig. 374. Barikot, Stupa A and B. General view from N to S. In the foreground, Stupa B; in the background, Stupa A. (Scerrato 1959; Neg. CS).



Fig. 375. Barikot, Stupa A and B. General view from S to N. In the foreground, Stupa A; in the background, Stupa B. (Taddei 1959; Neg. CS).

A. Stupas



Fig. 376. Barikot, Stupa B. S side. (Taddei 1959; Neg. CS).

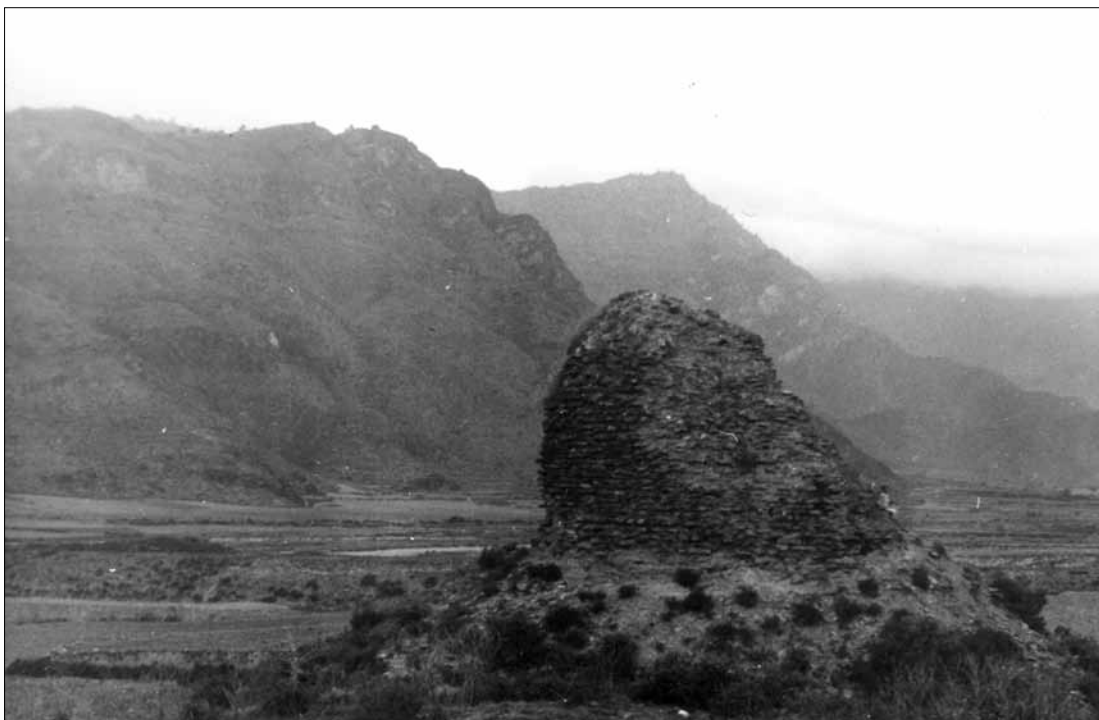

Fig. 377. Barikot, Stupa A. S side. (Taddei 1959; Neg. CS).



Fig. 378. Barikot, Stupa A. S side. (Taddei 1959; Neg. CS).



Fig. 379. Barikot, Stupa A. S side, detail. (Taddei 1959; Neg. CS).



Fig. 380. Barikot, Stupa A. NE side, with a short stretch of the preserved facing; belonging to the upper part of the transition storey of the composite dome and to the lower part of the same dome raised with projecting slab; elevation. (Scerrato 1959; Neg. CS).



Fig. 381.
Barikot, Stupa
A, profile
showing the
projecting slab
of the dome.
(Scerrato 1959;
Neg. CS).

A13. Stupa of Top dara (Haibatgram, Thana)

(Figs. 382-414)

The Site

Zone of Thana.

Position: Lat. 34° 38' N; Long. 72° 06' E; SPM 43 B/2.

Coming from Mingora-Barikot, passing beyond Landakai and then Jalala (that is, entering the Malakand Agency), before reaching Thana a large semi-circular plain is encountered on the left, enclosed by Mt Morah-sar. On the W slopes of the mountainous semi-circle, following the unsealed road leaving the village of Haibatgram and running along the wide winding bed of a tributary of the Swat, leads to a small flat area. It is here that the sacred complex stands, dominated by the stupa. The terrace is bounded close up on the two sides, to the S and N, by two small sunken torrents that, in front of it, flow into the main torrent.

After leaving the torrent the road rises and turns behind the stupa, between it and the monastery which extends eastward at a higher level (c. 4.00-5.00 m); it continues and splits in two: to the S, it enters a narrow valley along which flows the S branch of the torrent and to the N it follows the other branch, ending in a still active stone quarry. The S branch shortly after leads to a spring in the shade of a plane tree at the foot of the mountain slope.

From the monastery it is possible to see the quadrangular perimeter raised at the edges corresponding to the rows of cells, with the central depression of the courtyard. Stein observed four rooms on each side, provided with a dome with a span of about 8 ft. Nowadays, to the E, a line of masonry of a construction similar to that used in the stupa is visible.

On the mountain slope, to the S, a well conserved tall tower, square in plan, stands (a defensive work?) (Stein 1930: 7).

The sacred complex is very interesting: relatively contained, organized as a stupa, monastery, spring, tower; probably water regulating works along the ditches, scattered dwellings in the valley.

Bibliography and Documentation

Foucher 1905-1951: 74, 76, figs. 17-18 ⁽¹⁾.

Observed by Stein (1930: 6) in 1897 (Malakand campaign); then Stein 1930: 6-7, fig. 1, pl. 1 above ⁽²⁾.

Barger & Wright (1944) and Tucci (1958) do not mention it.

Franz 1959: 141, pl. IV.10; text repeated in Franz 1965: 88, fig. 142: the monument

⁽¹⁾ 'Un autre *stūpa* du Swāt, caché au fond d'un vallon qui en a pris le nom de Top-Darra, à environ mille au sud-est de Haibatgrām, compte, pour ainsi parler, une zone ou assise transversale de plus, ayant en outre intercalé une terrasse ronde au-dessus de sa base quadrangulaire (fig. 17). Celle-ci a survécu presque intacte, sauf du côté de l'escalier qui montait au second étage et que des fouilles superficielles ne manqueraient pas de dégager. Nous avons seulement pu relever, parmi les débris écroulés, quelques fragments de larges pierres plates, vestiges des parasols qui jadis surmontaient le sommet'. 'Une telle abondance de documents et un tel accord de témoignages nous ont contraint à tenter du mieux conservé de nos stūpa une restauration tout approximative, mais qui, à prendre les choses en gros, ne paraît pécher que par excès de prudence (fig. 18)'. The caption of figure 18 is 'Essai de restauration théorique du précédent', that is the caption of the figure showing the Stupa of Top-Darra (fig. 17).

⁽²⁾ 'Stūpa de Tōp-dara — The next day was to bring me within the territory of the Ruler of Swāt, beyond the Landakai spur which marks its western boundary on the left bank of the river. I used the short march from Thāna, done mostly under drizzling rain, to visit the ruined Stūpa which is situated in a small valley opening to the south-east of the village of Haibat-grām. The valley takes its name, *Tōp-dara*, from the ruin. I had seen this Stūpa already in 1897 and well remembered its comparatively fair state of preservation. Leaving Thāna which since the Pax Britannica was extended over Lower Swāt has grown to quite town-like proportions, we reached Haibat-grām by the main road after about a mile and a half. By the side of the torrent bed which descends from Tōp-dara and only half a mile or so to be the south of the village I notice a large mound, measuring about 78 by 60 yards, called *Bābujān*. It marks the position of a completely destroyed Stūpa of which the stone materials are known to have been carried off long ago for use in the dwellings of Haibat-grām and Thāna. The way beyond led over a low and narrow plateau which judging from abundant stone debris must also have once been occupied by dwellings. But only at a spot known as *Damozai*, about half a mile further up and near the entrance of the picturesque glen containing the Tōp-dara Stūpa, could remains of ancient walls built with masonry of Gandhāra type be traced *in situ*.

'The ruined Stūpa, seen in fig. 1, occupies a narrow plateau between two torrent beds which meet close below it. The plateau has been enlarged by stone-built platforms the supporting walls of which, as the foreground in the photograph shows, still stand in places to a height of 12 feet or more. The structural features of the Stūpa, as shown by the sketch plan and section in pl. 1, are typical of most of the Stūpas examined in Swāt. On a rectangular base measuring 52 by 46 feet and about 13 feet high there rise two circular bases having a diameter of 36½ and 28½ feet, respectively. Their heights are 7 and 6 feet, respectively, including low plinths. Above a projecting cornice of the uppermost base there rises the dome on a drum, 27 feet in diameter. As the top of the dome has been broken its full height could not be ascertained, but it certainly was over 20 feet. The lowest base was provided with stairs, 13 feet wide, on its S.E. side. On that side a broad cutting carried through both upper bases right to the centre showed where treasure-seekers had been at work long ago. All three bases were decorated with pilasters 1 foot broad and projecting 3 inches; but most of these are now marked only by the matrices which their crumbling masonry of small stones has left in the far more solid facing of the Stūpa. This consisted of roughly dressed large slabs, with small flat pieces of stone filling the lateral interstices in the usual Gandhāra fashion and equalizing the courses. There were indications of the whole of the Stūpa having been coated with hard plaster.

'On higher ground to the S.E. of the Stūpa, at a distance of about 25 yards, there are found the much decayed remains of a quadrangular structure measuring about 100 feet square. It appears to have comprised on each side four small domed chambers, grouped round an open court. The domes had a span of about 8 feet, and rested with their horizontal courses on carved slabs of stone rounding off the corners of the square chambers. There can be no doubt about this quadrangle having served for monastic quarters. About half a mile up the glen there is found a small perennial spring, and on the steep slope to the S.W., at a height of about 200 feet above the site, there rises boldly a massive high tower of square shape. It may have served as a place of safety for the small monastic community in troubled times'.

depicted is Amluk Dara (see no. A9).

It was the first stupa visited in 1955 by Tucci and his group (Felice Benuzzi, Raoul Curiel, Waliullah Khan, Domenico Faccenna) when he arrived in Swat.

Faccenna 1961: reconnaissance of the area.

Visit by Francine Tissot in 1963 (1985: pl. IX.6, fig. 41).

Khan M. Ashraf 1993: 66-67, pl. XVII, fig. 52.

Kuwayama 1993: photographic campaign.

Nascari 1993: photographic campaign.

Sabelli 1993: survey and photographs; several of which taken from the same points of view as Foucher and Stein.

Khan M. Bahadur 1999: 25-26 fig. a (general view, N side), b (general view, S side with the cut through the monument core) ⁽³⁾.

Rhie 2002, II: 642, fig. 4.44f (after *Koutcha*, III: fig. 263) ⁽⁴⁾.

An interesting comparison may be made among the photographs in Foucher, Stein, Tissot.

The photo by Foucher (1905: fig. 17) shows the perspective of the S side of the stupa. The cylindrical storeys with the gaps left by the pilasters have been conserved, together with the high dome with its facing outlining the curvature, the 1st storey that displays between the missing part on the right and the collapsed corner on the left a conserved section comprising six pilasters. The monument profile reveals the absence of all the storeys on the right side with the collapsed stones at its base; the cut had already taken place. Foucher does not mention the origin of the photo, which he himself probably took (?). The same photograph is reproduced by Rhie (2002: fig. 4.44f) taken from *Koutcha* III, fig. 263. There is also a person on the dome who is missing in the one reproduced by Foucher; perhaps removed by retouching.

Then there is Stein's full page, extremely conspicuous photograph (1930: fig. 1). It consists of a wider view of the monument with the supporting wall. It was taken from below, in alignment with the collapsed SW corner. In the time elapsing

⁽³⁾ 'There is a beautiful stupa hardly a few kilometres from the main road near Haibatgram village. The stupa is approachable through a dry river bed. The stupa has been criminally robbed of the relics from the Southern side and greatly damaged by the fortune seeker. In its present state the stupa and the surrounding area have been searched by antiques seekers and precious relics have been removed. The southern portion has been made open no doubt for taking out the relic casket. In this process heavy losses have been inflicted. Apart from human vandalism, nature has also left ugly scars on the face of this beautiful site. The stupa is of course a splendid one in Malakand Agency and worth preserving. If developed and suitably preserved the site can be converted into a potential resort. Presently there is urgent need for taking concrete steps to preserve the site from further damages mainly due to rainwater'.

⁽⁴⁾ 'The style of the Southwest Stupa of the Subashi Eastern Site is clearly descended from the stupas of Gandhāra, as represented by the Loriyan Tangai stupa in fig. 4.44e and by the brick [sic] stupa of Top Dara in Swat in fig. 4.44f, both probably made in the 2nd century A.D. as well as others, such as the stupa of Mohrā Morādu at Taxila, all of which, however, have a more hemispherical shape to the dome compared with the more attenuated or 'parabolic' shape of the Subashi stupa'.

after Foucher (about thirty years) the monument suffered some relatively slight damage; more serious on the S side, where the pilasters have been reduced to five in number, two of which remain only in the form of gaps.

This situation is still apparent in the photo taken in 1963 and published by Tissot (1985: fig. 41); it was taken from the same point of view as Stein's, but from a slightly higher level ⁽⁵⁾.

Foucher (1905: fig. 18) suggests an approximate ('théorique') reconstruction of the stupa, which is characterized by the use of different orders in the storeys (from the bottom: Corinthian, Persepolitan, arched, double flight of steps and pilasters of the 1st storey, 9 in number including the corner ones (cf. the reconstruction of the Stupa of Top-e-Rustam in Foucher 1942, I.1: 91, fig. 24).

The Stupa

The stupa, extraordinarily well conserved until just after the middle of the 20th century (Foucher, Stein, Tissot photos), is now in a wretched state of destruction, reduced to the core alone which has been emptied on the inside. The most serious damage thus occurred after this period, in relatively recent times. After the destruction of the wall, which emerged quite clearly from the 1st quadrangular shaped storey, a few very small sections of the 2nd and 3rd storeys (drum) remained; the composite dome is conserved with the transitional 4th storey and the dome, with the wall severely curtailed in height from which, proceeding upwards, a portion of the core still emerges.

The facing consists of relatively carefully dressed, rectangular blocks of schist or limestone, with the interstices on all four sides filled in with small schist slabs. In the 4th storey there are 9 rows of these blocks. The core is made of regular levels of closely spaced large slabs and schist blocks bonded with yellowish clayey soil.

The E section of the stupa presents a large gap which penetrates as far as the centre, from the top to the level of the stairway; from here it continues as a circular shaft reaching down as far as the stupa base. At the bottom a structure is visible on the wall made of stones and chips, circular in plan (diam. 2.00), with an initial curvature at the top (diam. 2.50): it may be interpreted as the impression left by a small monument, a stupa, enclosed in it and later plundered and removed as has been observed elsewhere (Stupa of Loebanr); or else the remains of a relic chamber, although the curvature of the wall does not support the latter hypothesis.

The following description is based on the situation regarding the monument as

⁽⁵⁾ Tissot (1985: 256) gives the reference 'cliché Jacques Biltgen et Guy Thomas. 12, rue de Tournon 75006 Paris' and asks for 'J. Biltgen, 1963. Paris' to be included in the caption. From fig. 41 is taken the small sketch in pl. IX.6, p. 171.

shown by the photographs of Foucher and Stein, with the accurate, precise notes of the latter.

Platform

The structures designed to support the terrace on at least three sides are no longer visible, having been destroyed or covered by heaps of soil and stone debris; they appear in Stein's fig. 1 in the lower left foreground which gives a h. of 12 ft. and more.

1st Storey, Quadrangular in Plan

All the facing has been lost except for a few blocks still in situ; beneath the heap of debris a few very small sections of the N and W sides are still visible, which give us the two N corners from which it is possible to obtain the measures of the storey (S 15.84 x W 14.00). Stein gives the measures as 52 ft. x 46 ft., with a h. of c. 13 ft.

The wall was divided on the three free sides by tall narrow pilasters, 1 ft. wide and projecting by 3 in., eight in number on the S side with a mean estimated interaxis of 2.30; and by the same number on the W side with a different interaxis (2.00). Several pilasters on the S side were conserved, as shown in the photographs, with capital, modillion, and missing architrave in the upper part.

These decorative elements are visible only in the conserved section of the 3rd storey, which also provides some indication of its base and of the base of the pilaster with part of the shaft: both bases are of the scotia type. This profile may be extended to the 1st and 2nd storeys.

The stupa has a stairway on the E side covered by collapses and partly below the road level. Stein gives it a width of 13 ft., a measure that could be attributed to the projection, which is certainly present, provided with internal and external corner pilasters. With the storey's height of 13 ft. the number of steps may have been 15, considering the mean value of the measure normally attributed to them, with an inclination of 39°. The presence of a second flight of stairs corresponding to the 2nd storey, as in Foucher's hypothetical reconstruction, may be ruled out.

2nd Storey, Circular in Plan

Set back by 2.42 (W) and 1.50 (N, S); h. 2.47, diam. 11.00. Stein gives the following measures: h. 7 ft., diam. 361/2. It too is decorated with pilasters, lower width 0.22 (Stein gives 1 ft. 3 in. projection), which may be calculated as 18 in number with a mean interaxis of 2.00.

The storey has a scotia base with three-sided bevelled torus, flat scotia and cavetto with gradually receding small slabs.

The base of the pilaster repeats the scotia motif in simplified form. A short section of the shaft has been conserved below; missing are the capital, modillion and cornice, which can be considered similar to that of the 3rd storey, where these elements are better conserved.

3rd Storey, Circular in Plan (Drum)

Slightly set back (by 1.10); in a S section it provides us with greater evidence than the 2nd storey (h. 1.86, diam. 8.80). Stein gives the following measures: h. 6 ft., diam. 281/2 ft.

The now missing base of the stupa may however be reconstructed. We thus have the pilaster, lower width 0.20 (Stein gives 1 ft. and a projection of 3 in.), with scotia type base. There are gaps in the wall corresponding to the shafts and the capitals. Still conserved are the three rows of schist slabs of the modillion, with the typical small slab placed separately at the end of the bottom row representing its extremity in the cavity, and then the architrave composed of blocks and small slabs and the cornice with its corroded superimposed slabs including the ovolo, which must have been followed by the cavetto and reverse ovolo; coping slab missing. The plaster coating outlined the cornice profile, as well as probably the division of the architrave into two zones and the modillion profile with the termination at the sides of the cavity.

There may have been as many as 18 pilasters with a mean interaxis of 1.60.

4th and 5th Storeys (Composite Dome)

4th Storey, Circular in Plan, Transition Element

Slightly (0.20) set back with respect to the 3rd storey wall, the 4th storey, 1.50 tall with a diam. of 8.60, is slightly re-entrant in the upper part as it rises, with a partly smooth wall structure made of very closely spaced and carefully laid blocks.

A. Stupas

5th Storey, Raised Dome

The dome rises, slightly re-entrant with respect to the storey below, resting on a short projection (0.11) produced by large slabs. With a base diam. of 8.80 (Stein 1930: 27 ft.) the wall currently rises to a height of 2.38, which is severely curtailed with respect to that observed by Foucher and Stein. The core continues higher. The original height might have been 5.00 (Stein 1930: over 20 ft.).

Plaster

Observed by Stein, none of it is now conserved on the current remains of the structures.

It is nevertheless rendered in the reconstruction as it represents an essential element for defining the stupa profile.

Chattravali Disc

Left of the stairway a gneiss (?) disc is inserted vertically in the soil, part of which is missing, with an indeterminable diam.; it certainly belonged to the stupa.

Foucher recalls having noted fragments of 'larges pierres plates' of a pinnacle.

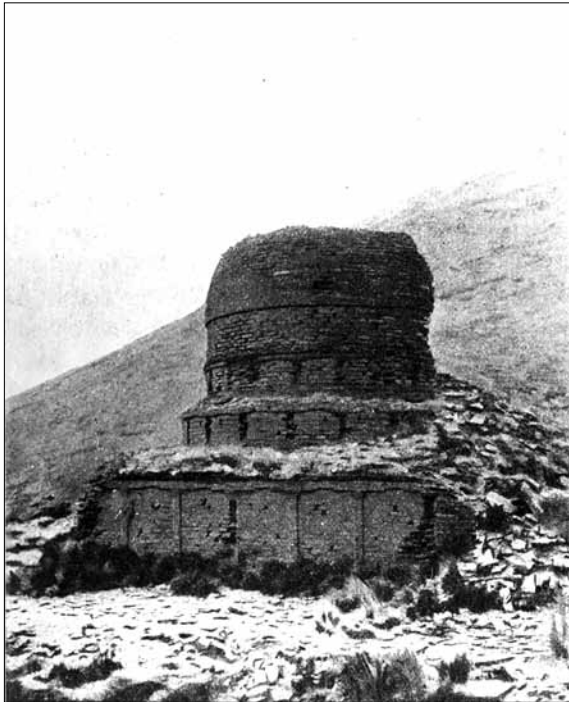

Fig. 382. Stupa of Top Dara
(Haibatgram, Thana). General
view from S. (After Foucher 1905:
fig. 17).

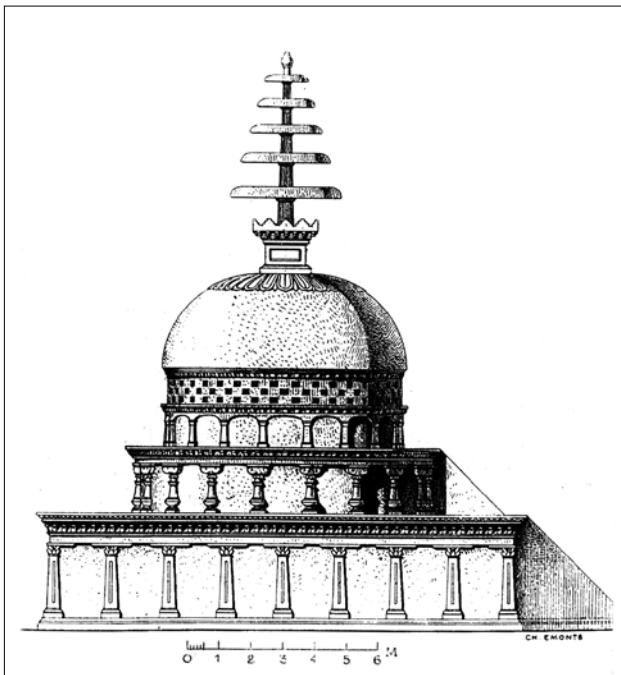

Fig. 383. Stupa of Top Dara
(Haibatgram, Thana). Hypothetical
reconstruction. (After Foucher
1905: fig. 18).



Fig. 384. Stupa of Top Dara (Haibatgram, Thana). General view from SW.
(After Stein 1930: fig. 1).

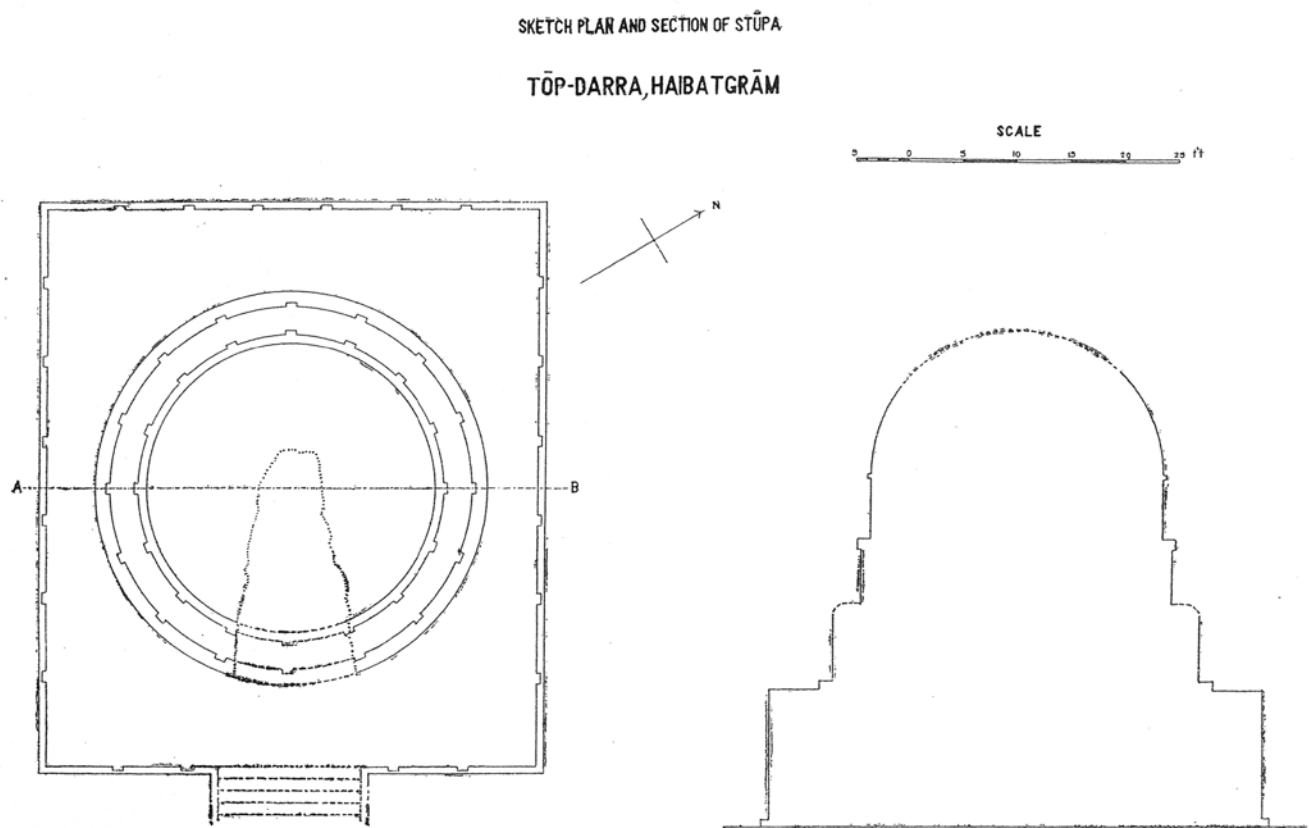

Fig. 385. Stupa of Top Dara (Haibatgram, Thana). Sketch plan and elevation.
(After Stein 1930: pl. 1, on the top).

A. Stupas



Fig. 386. Stupa of Top Dara (Haibatgram, Thana). Inspection towards the stupa of G. Tucci after his arrival in Swat, with R. Curiel, Waliullah Khan, D. Faccenna and others, 1955. (Diapositive of Felice Benuzzi, 1955).



Fig. 387. Stupa of Top Dara (Haibatgram, Thana). General view. (Diapositive of Felice Benuzzi, 1955).



Fig. 388. Stupa of Top Dara (Haibatgram, Thana). General view from SW. (After Tissot 1985: fig. 41; foto J. Biltgen, 1963, Paris).



Fig. 389. Stupa of Top Dara (Haibatgram, Thana). On the plain from W to the Stupa in the background, on the E. (Kuwayama 1993).

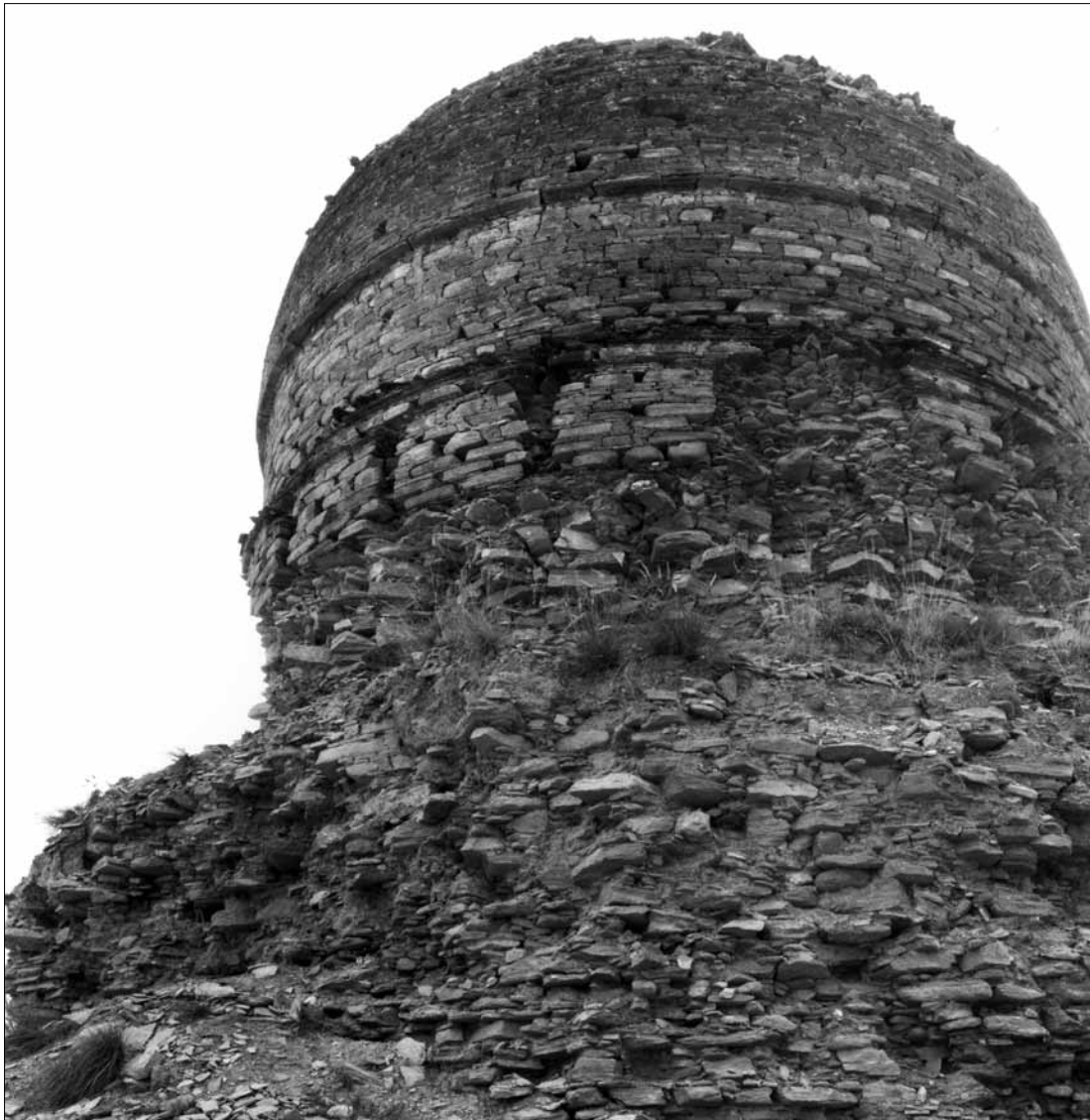

Fig. 390. Stupa of Top Dara (Haibatgram, Thana). S side; 3rd, 4th, 5th storey; at the bottom, a short stretch of the 1st storey wall. (Kuwayama 1993).

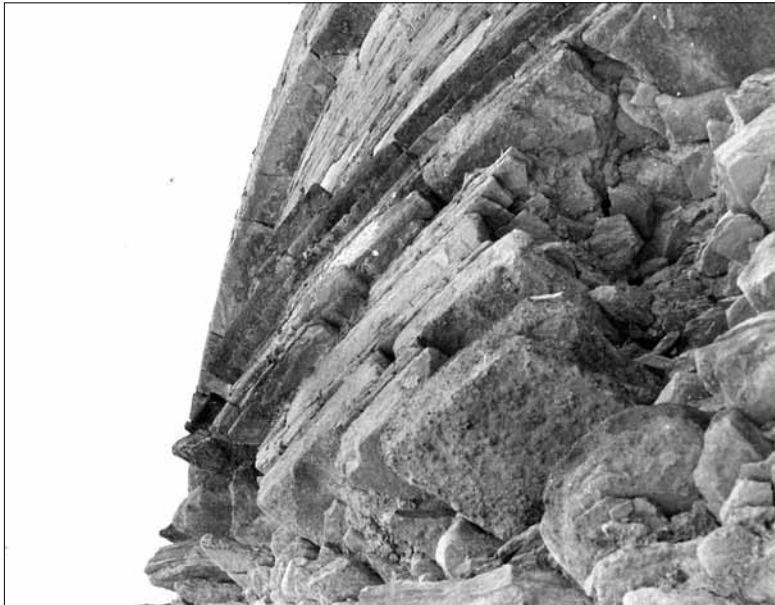

Fig. 391. Stupa of Top Dara (Haibatgram, Thana). S side; 3rd storey, detail. (Nascari 1993; Neg. CS).



Fig. 392. Stupa of Top Dara (Haibatgram, Thana). SE side; 4th and 5th storey and remains of the 3rd storey wall. (Kuwayama 1993).

A. Stupas

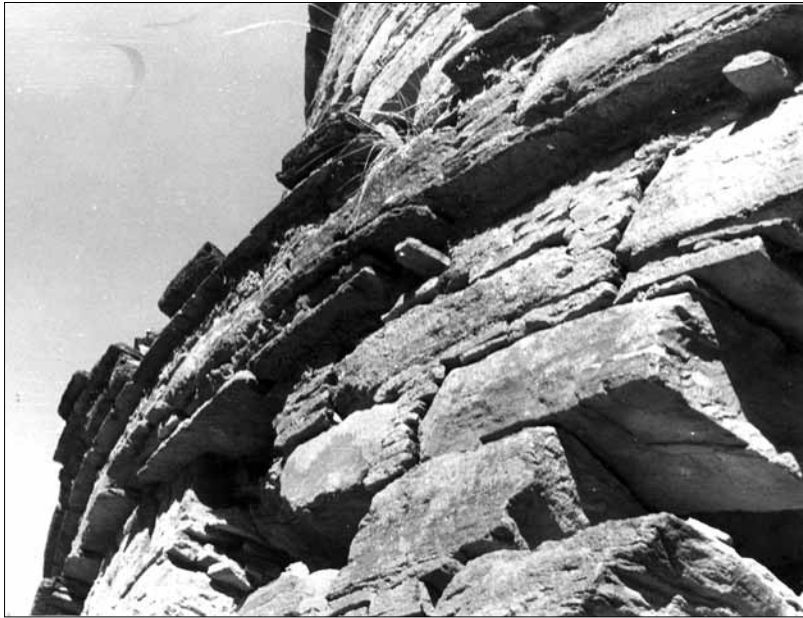

Fig. 393. Stupa of Top Dara (Haibatgram, Thana). SE side; 3rd storey, detail showing a modillion of pilaster and cornice, profile view. (Nascari 1993; Neg. CS).



Fig. 394. Stupa of Top Dara (Haibatgram, Thana). General view; SE side; 4th and 5th storey and a stretch of the 3rd storey. (Kuwayama 1993).



Fig. 395. Stupa of Top Dara (Haibatgram, Thana). General view; E and N sides; 1st storey and the cut through the 3rd, 4th and 5th storey. (Nascari 1993; Neg. CS).



Fig. 396. Stupa of Top Dara (Haibatgram, Thana). E side, on the left of the cut; 4th and 5th storey. (Kuwayama 1993).

A. Stupas

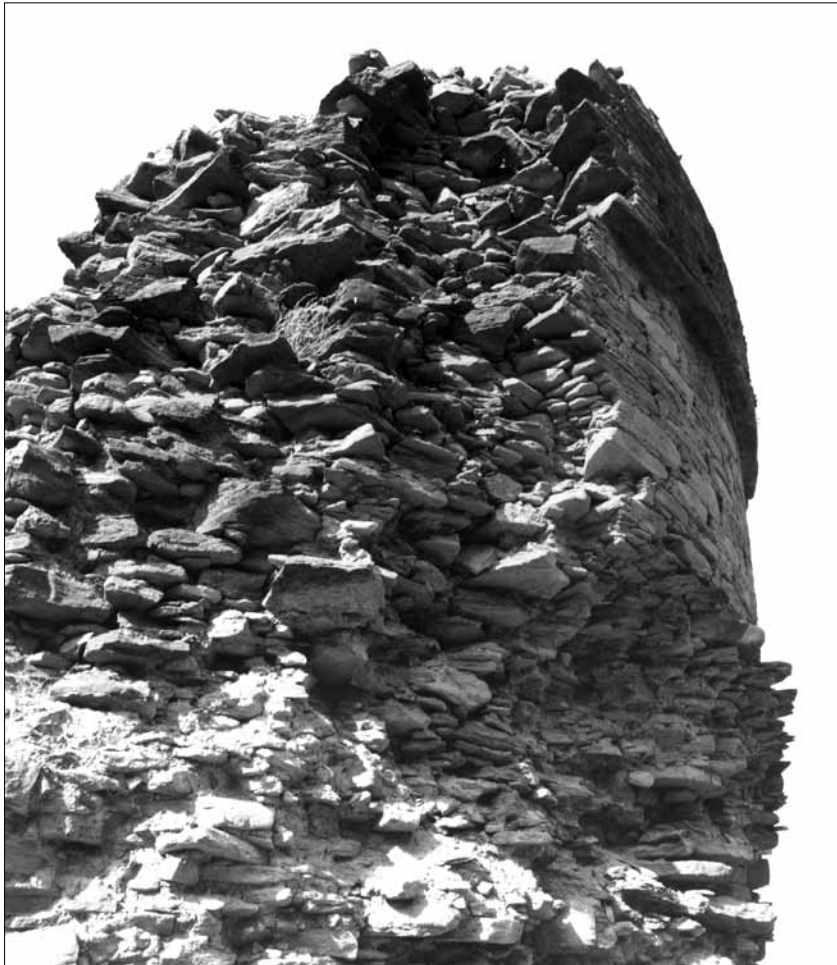

Fig. 397. Stupa of Top Dara (Haibatgram, Thana). N side, on the right of the cut; 4th and 5th storey. (Kuwayama 1993).



Fig. 398. Stupa of Top Dara (Haibatgram, Thana). E side; general view showing the cut through the stupa core; the quadrangular structure of the monastery looms in the foreground. (Sabelli 1993).



Fig. 399.
Stupa of
Top Dara
(Haibatgram,
Thana). E
side; general
view showing
the cut
through the
stupa core.
(Nascari 1993;
Neg. CS).

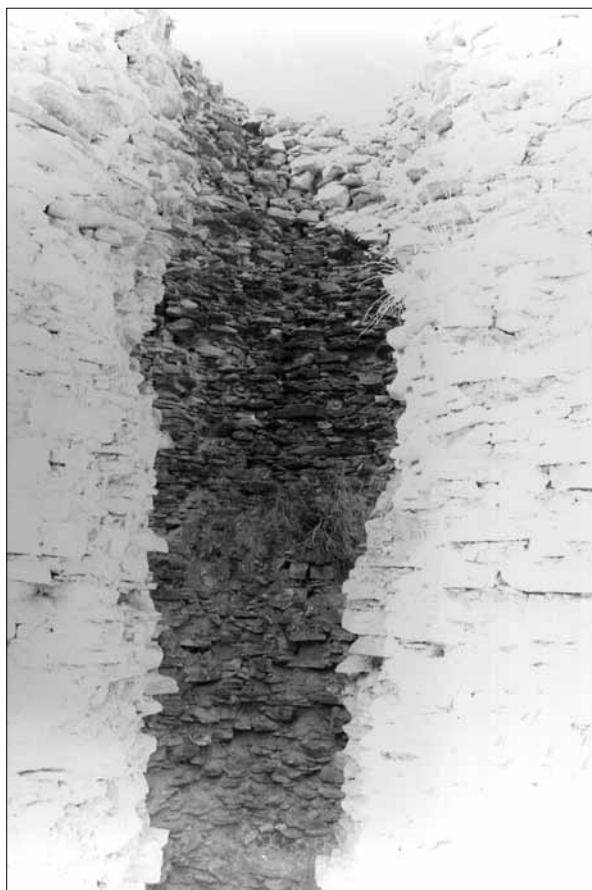

Fig. 400. Stupa of Top Dara
(Haibatgram, Thana). E side; the
cylindrical cut through the stupa core.
(Nascari 1993; Neg. CS).

A. Stupas



Fig. 401. Stupa of Top Dara (Haibatgram, Thana). E side, at the bottom of the cylindrical cut the impression of a curvilinear (dome-shaped) structure looms out. (Nascari 1993; Neg. CS).

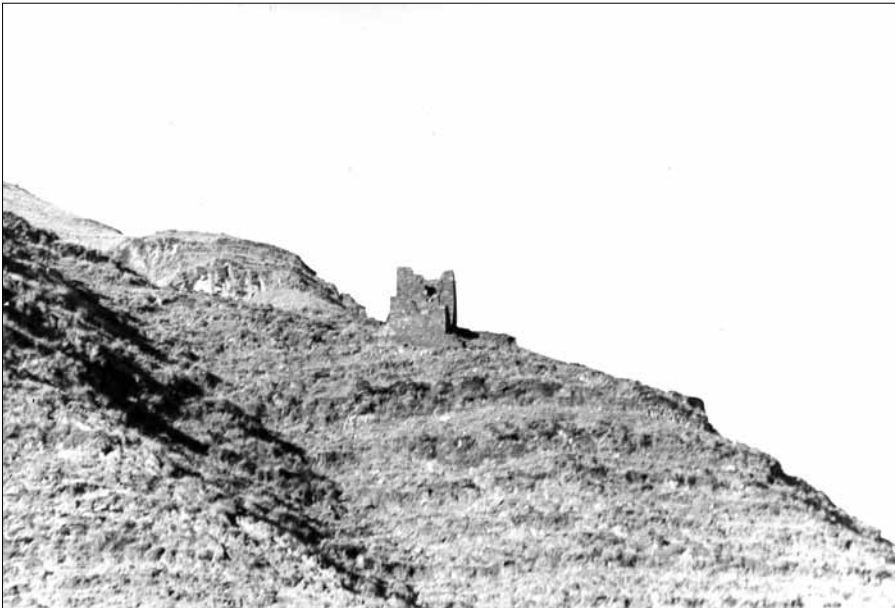

Fig. 402. Stupa of Top Dara (Haibatgram, Thana). On the S side of the mountain a high tower (or two; defence tower?) stands. (After Stein 1930: 7; see Nascari 1993; Neg. CS).

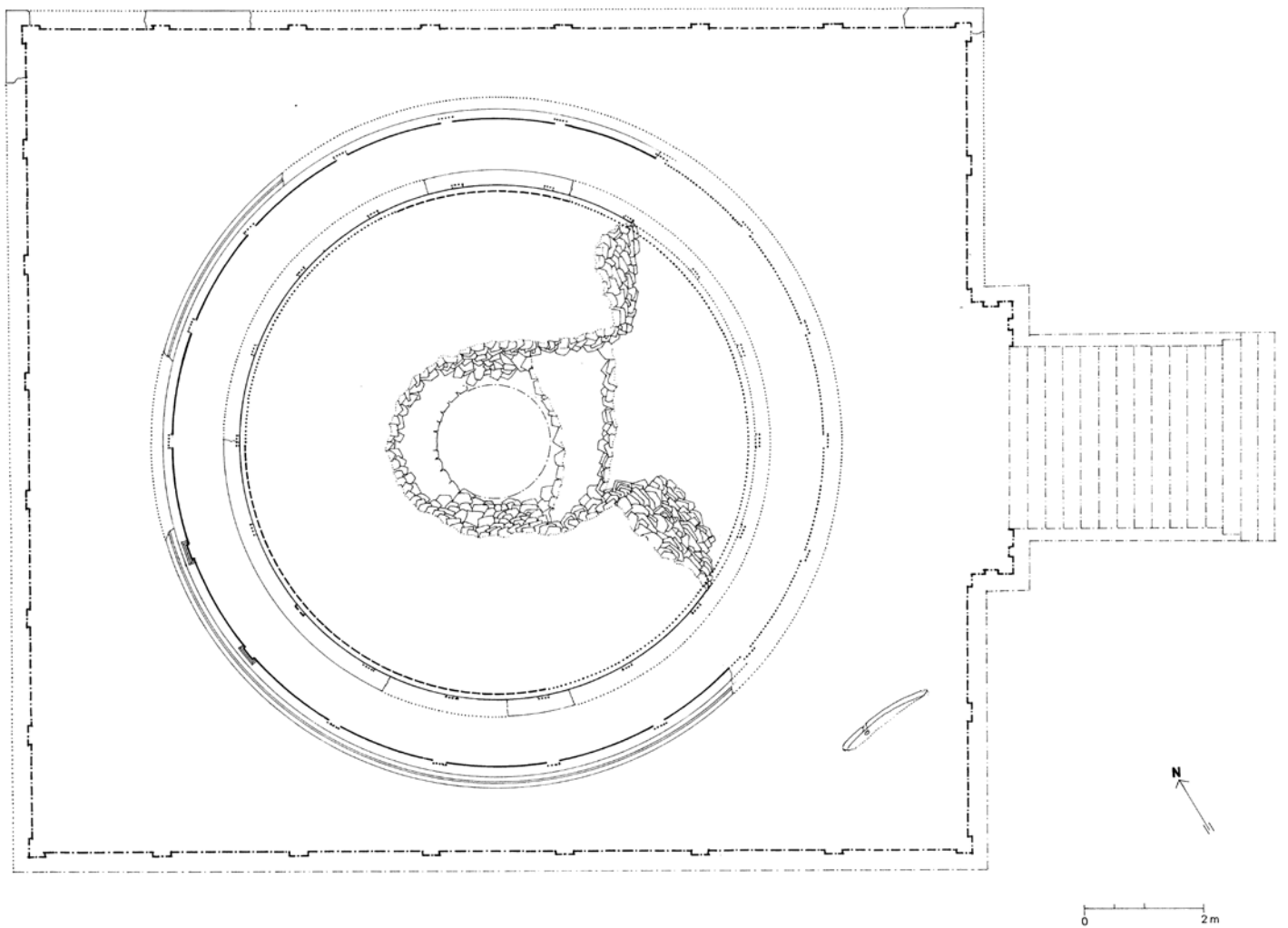

Fig. 403. Stupa of Top Dara (Haibatgram, Thana). Plan. (Sabelli 1993; Martore 2003).

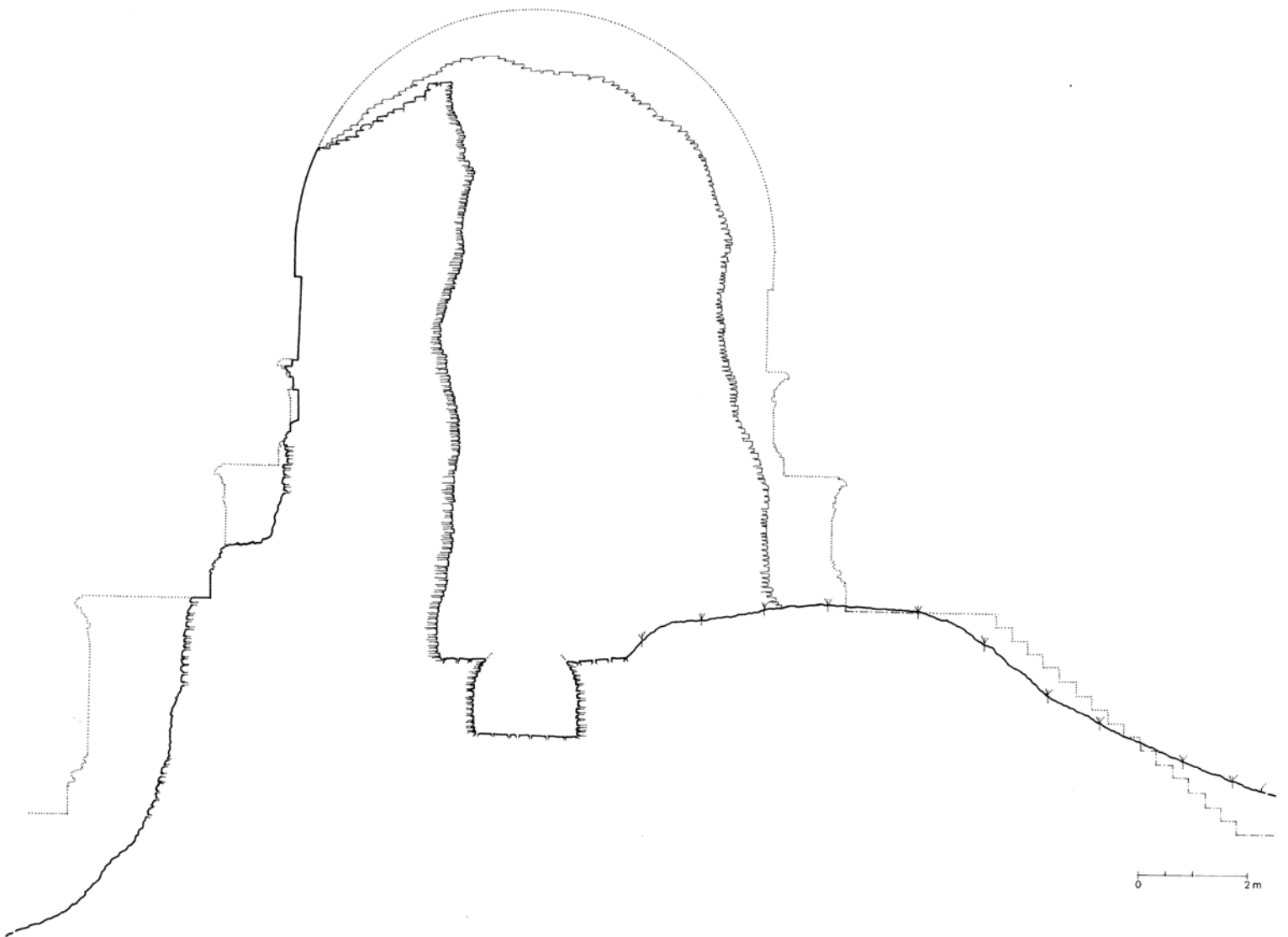

Fig. 404. Stupa of Top Dara (Haibatgram, Thana). W-E cross section.
(Sabelli 1993; Martore 2003).

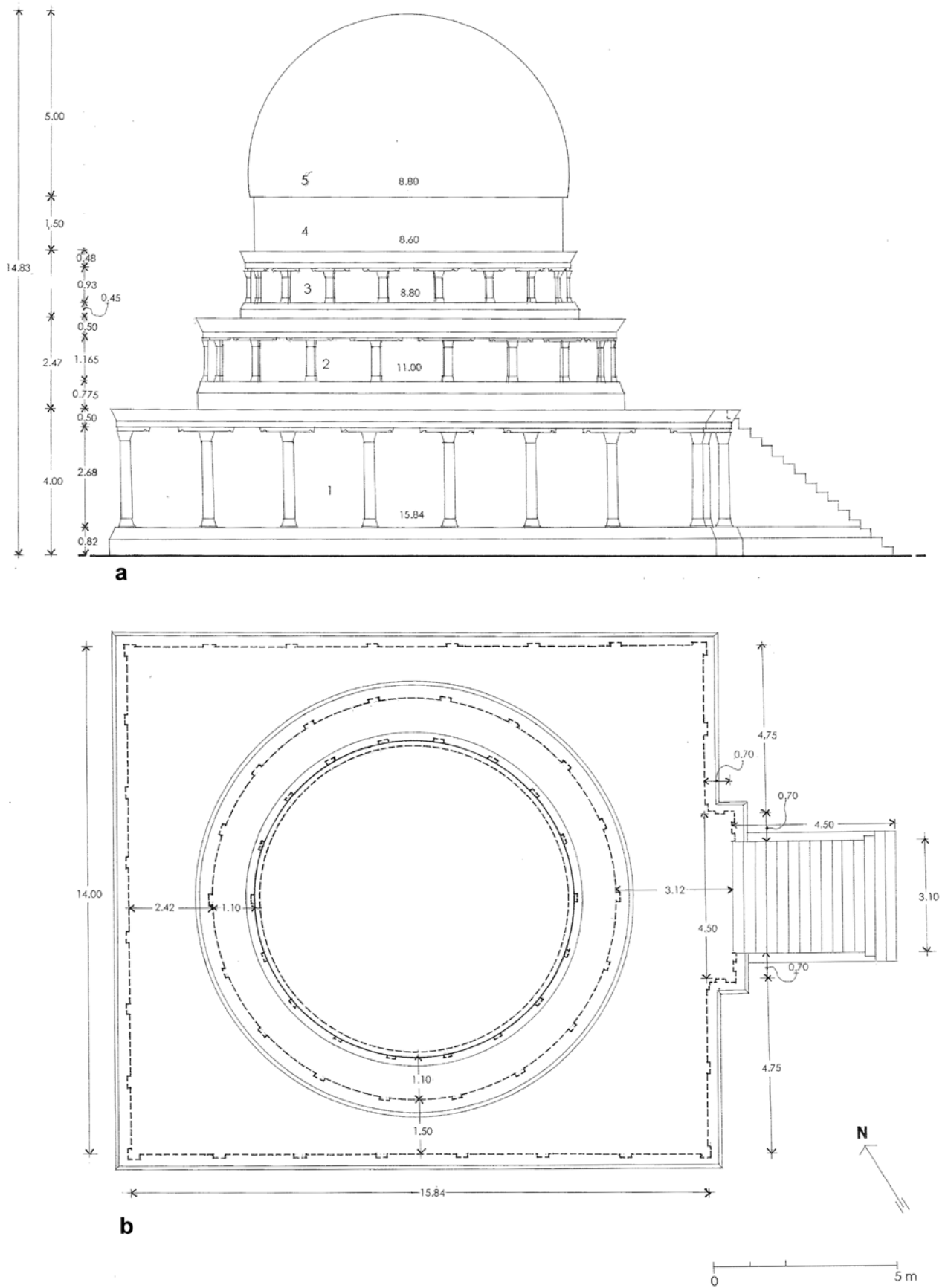

Fig. 405. Stupa of Top Dara (Haibatgram, Thana). *a-b.* sketch elevation and plan showing the measures. (Martore 2003).

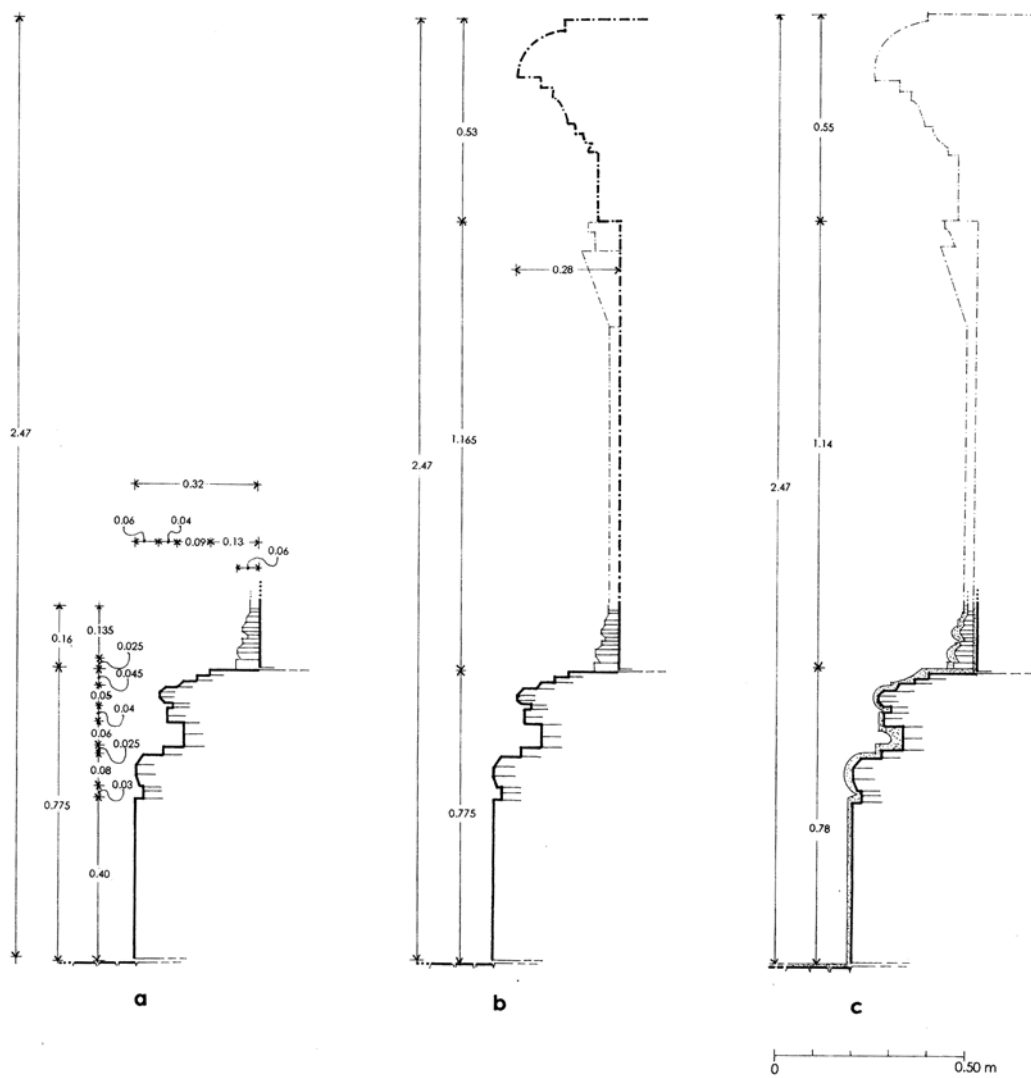

Fig. 406. Stupa of Top Dara (Haibatgram, Thana). 2nd storey. *a.* profile. *b.* reconstructed profile, without plaster. *c.* reconstructed profile, with plaster. (Sabelli 1993; Martore 2003).

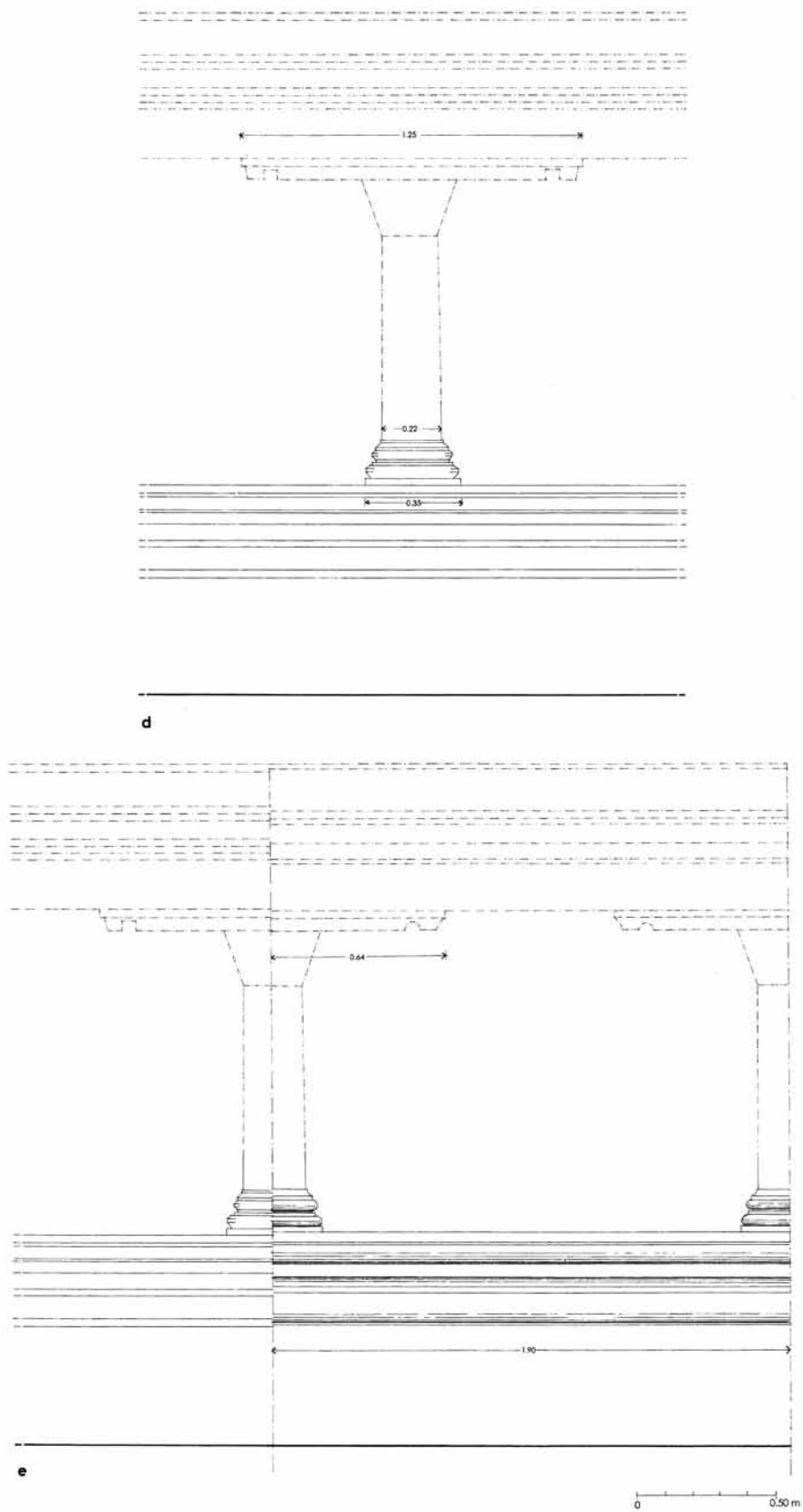

Fig. 407. Stupa of Top Dara (Haibatgram, Thana). 2nd storey. *d.* reconstructed elevation showing base, pilaster and cornice. *e.* reconstructed elevation showing base, centreline of pilasters and cornice. (Sabelli 1993; Martore 2003).

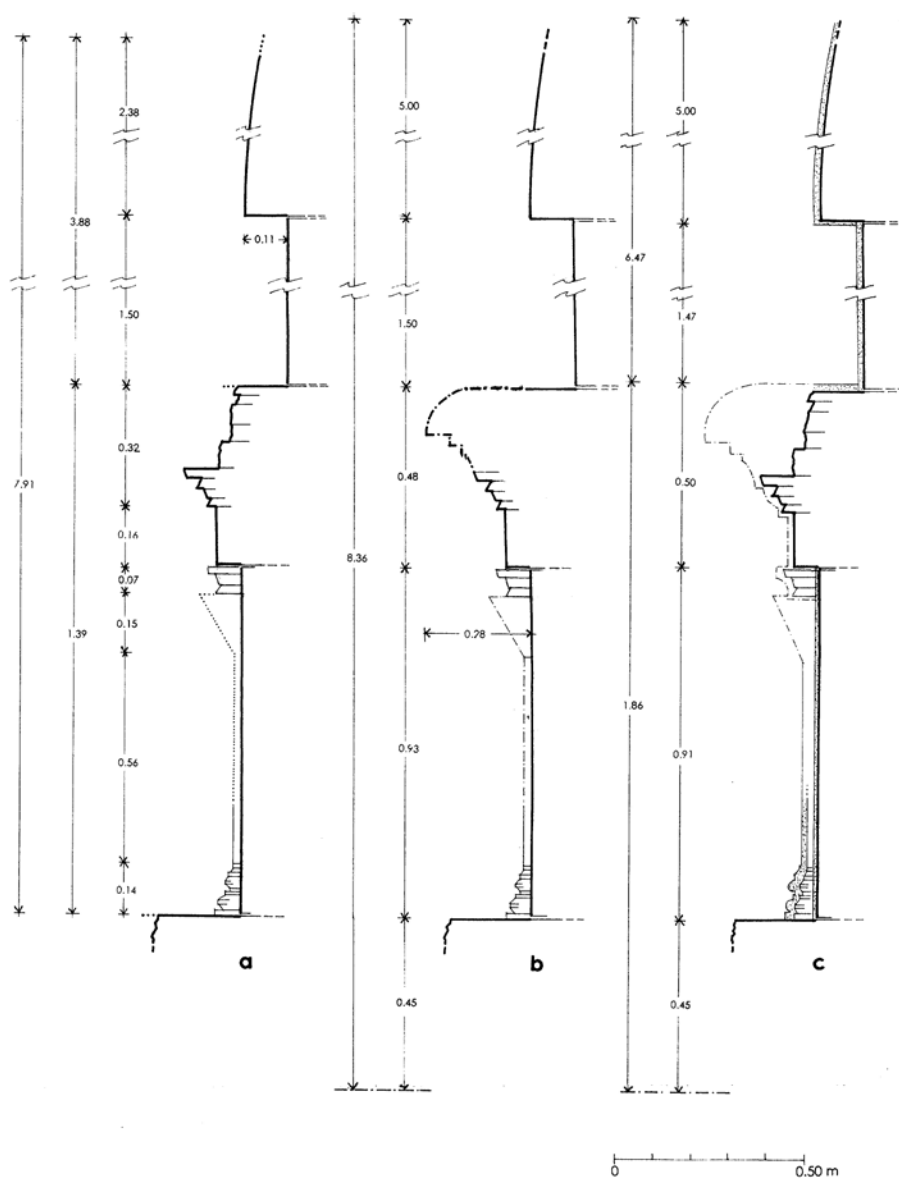

Fig. 408. Stupa of Top Dara (Haibatgram, Thana). 3rd storey (drum), 4th and 5th storey (composite dome, with transition storey and raised dome). *a.* profile. *b.* reconstructed profile, without plaster. *c.* reconstructed profile, with plaster. (Sabelli 1993; Martore 2003).

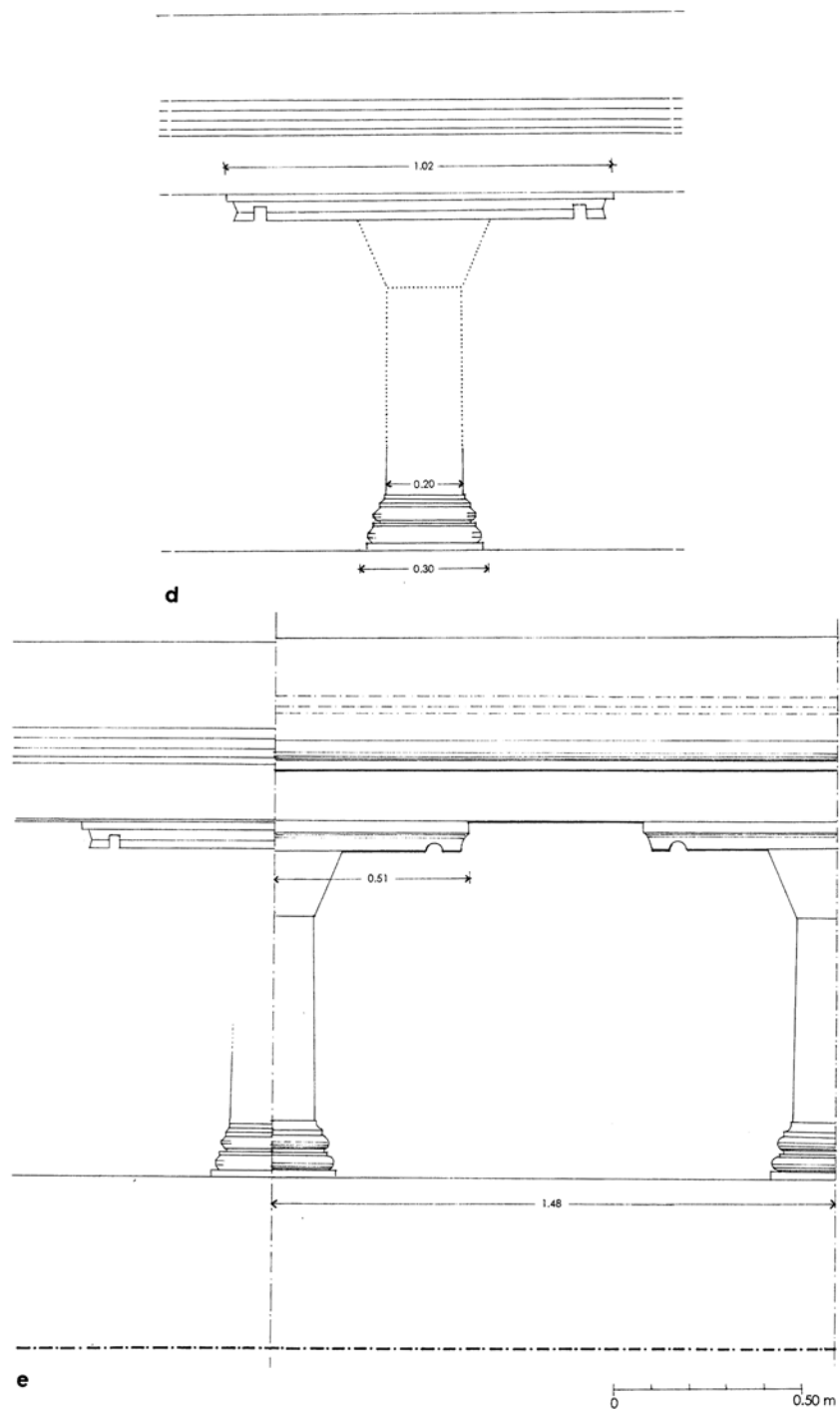

Fig. 409. Stupa of Top Dara (Haibatgram, Thana). 3rd storey (drum).
d. reconstructed elevation showing base, pilaster and cornice. *e.*
reconstructed elevation showing base, centreline of pilasters and cornice.
(Sabelli 1993; Martore 2003).

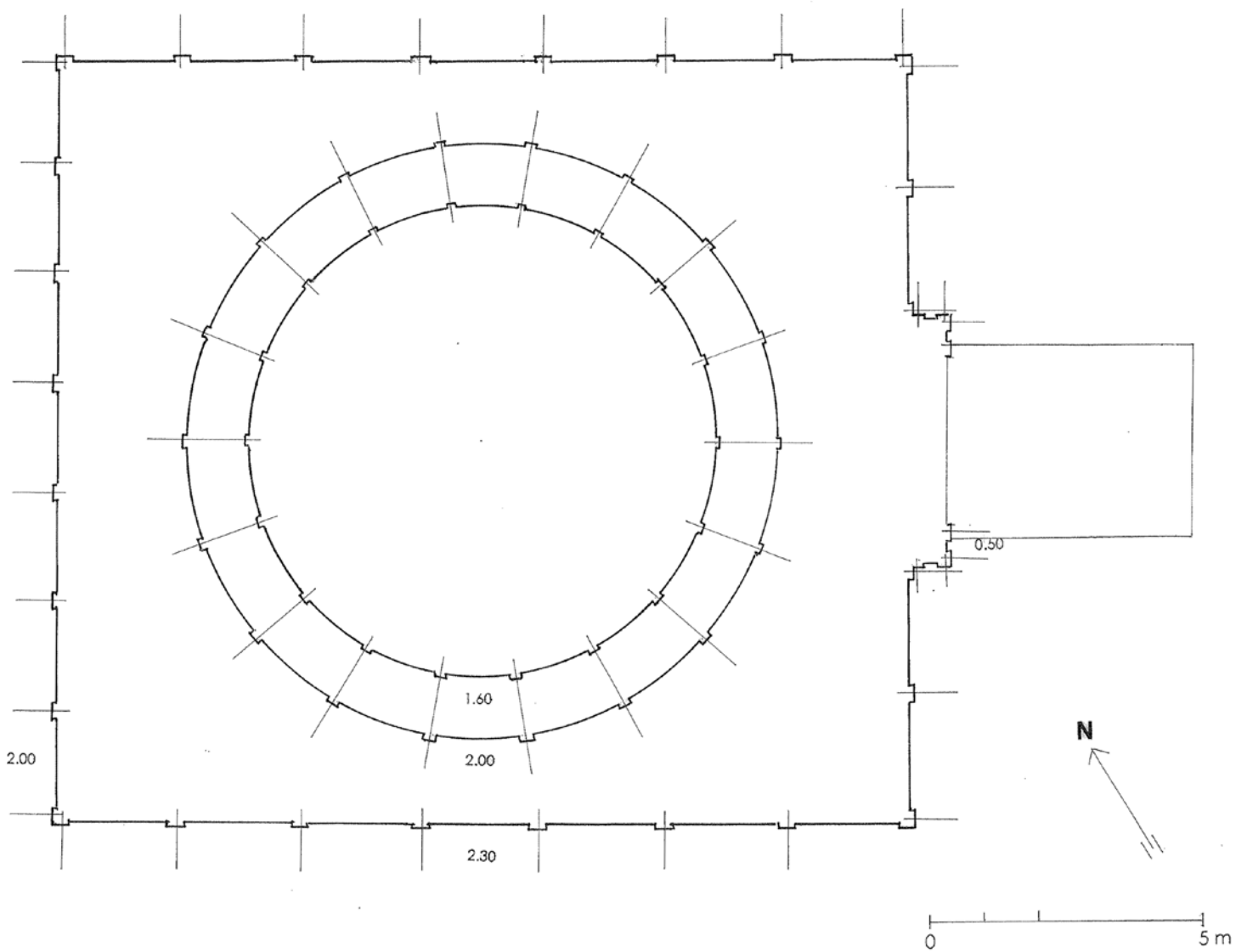

Fig. 410. Stupa of Top Dara (Haibatgram, Thana). Plan showing scheme of the pilasters axes. (Martore 2003).

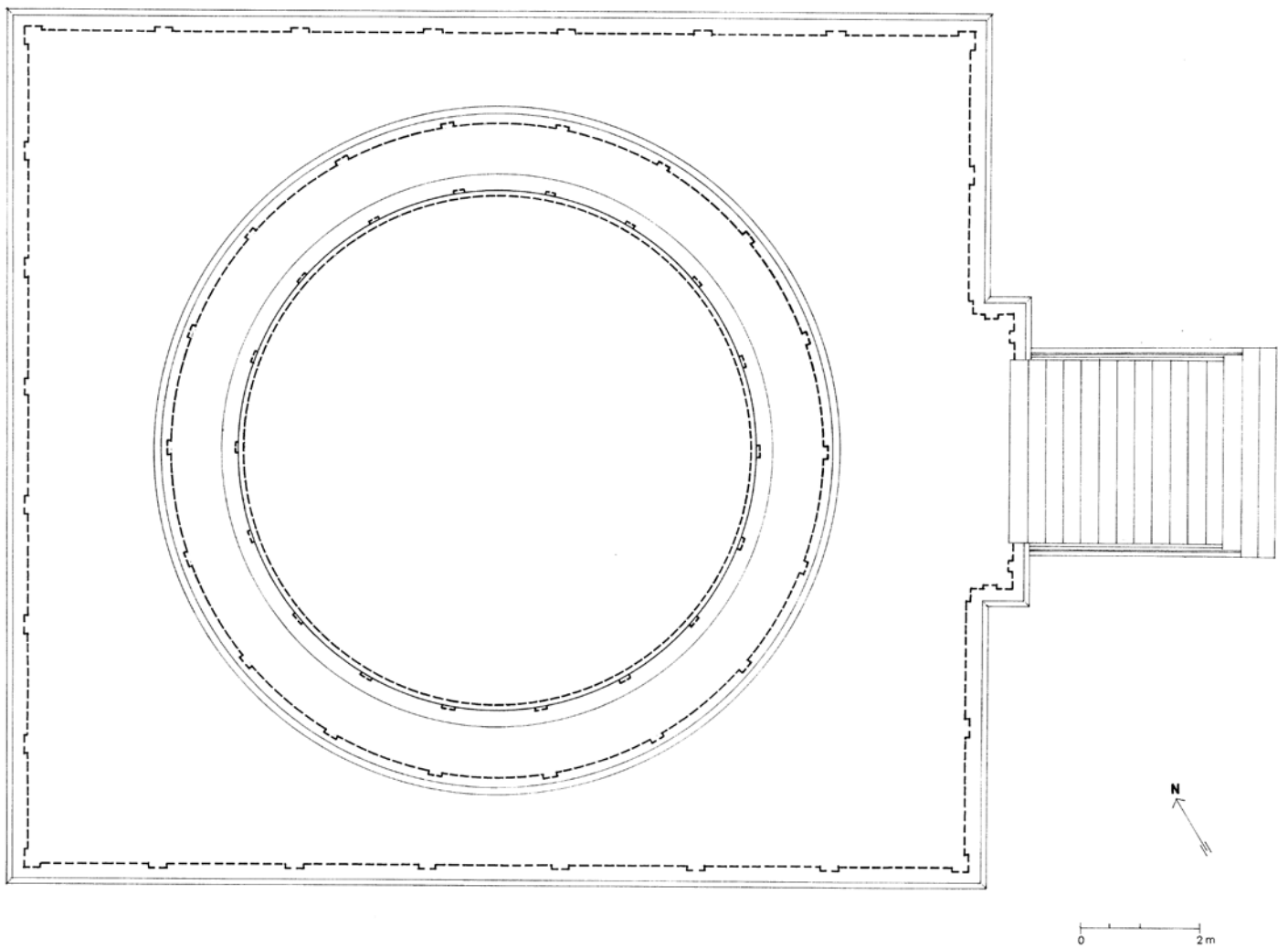

Fig. 411. Stupa of Top Dara (Haibatgram, Thana). Reconstructed plan.
(Sabelli 1993; Martore 2003).

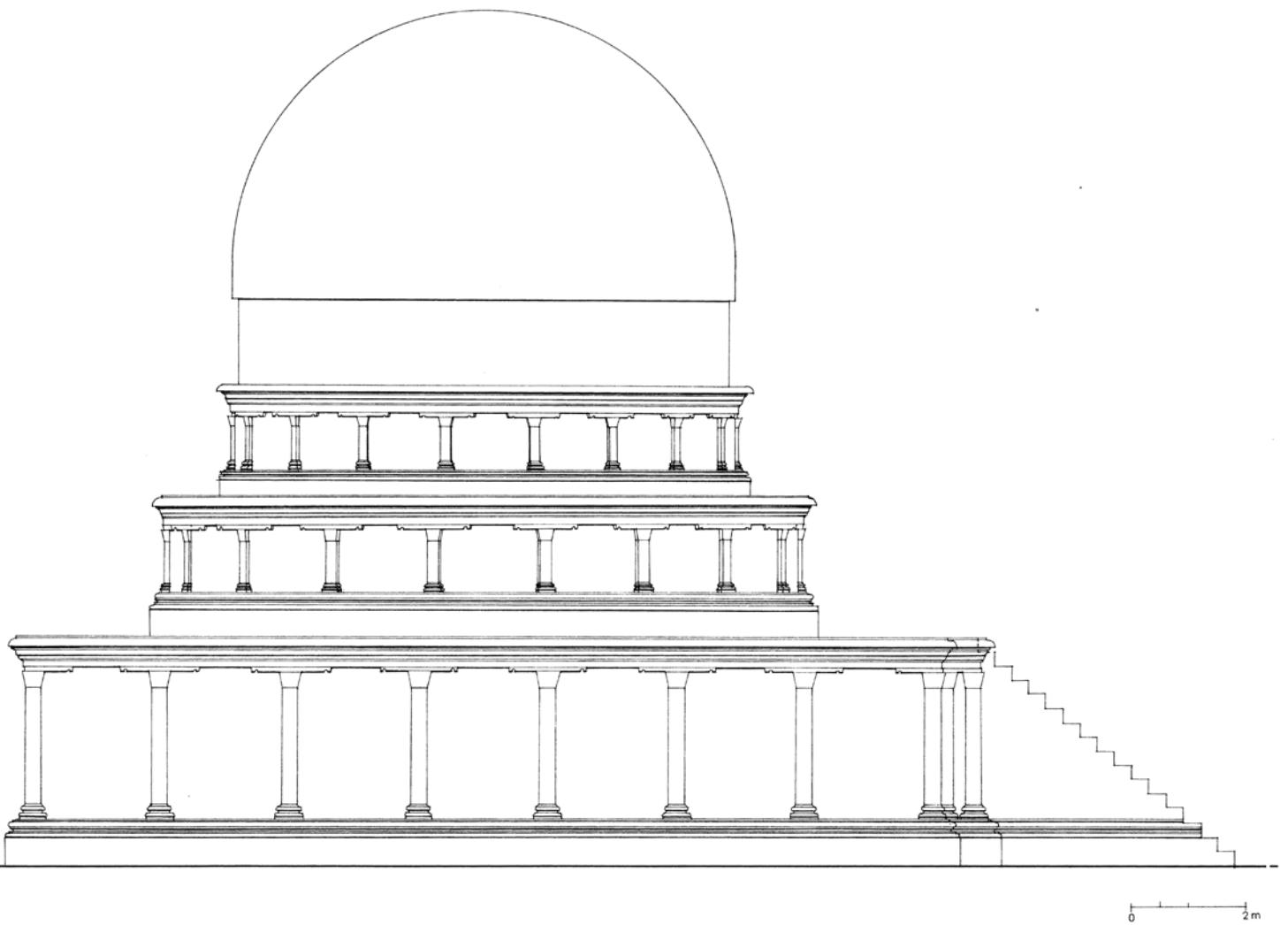

Fig. 412. Stupa of Top Dara (Haibatgram, Thana). Reconstructed elevation. (Sabelli 1993; Martore 2003).

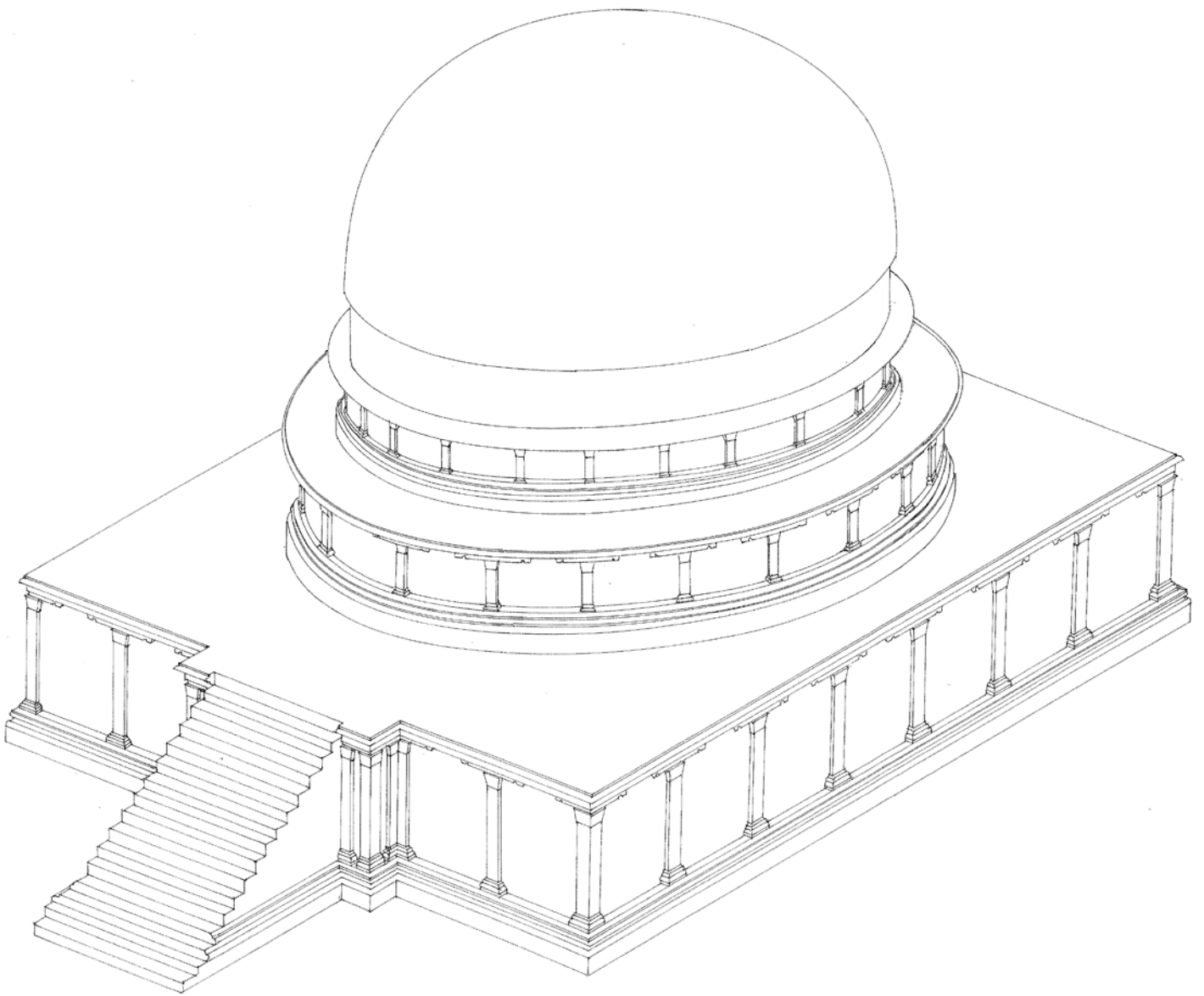

Fig. 413. Stupa of Top Dara (Haibatgram, Thana). Axonometric view. (Martore 2003).

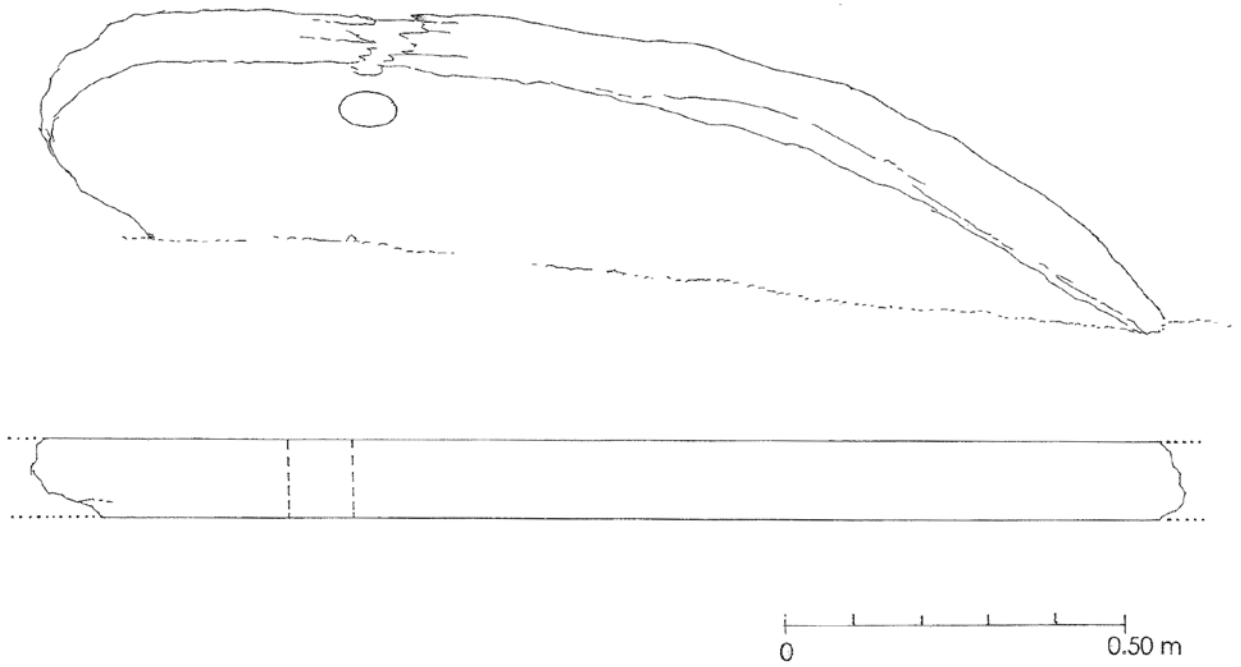

Fig. 414. Stupa of Top Dara (Haibatgram, Thana). Chattravali disk.
(Sabelli 1993; Martore 2003).

A14. Stupa of Gumbatuna

(Figs. 415-436)

The Site

Zone of Gumbatuna.

Position: Lat. 34° 41' N; Long. 72° 11' E; SPM 43 B/2.

The sacred area with the large stupa is situated on the right bank of the Swat river, to the right of the road following the river and proceeding southward towards Nimogram, after crossing the bridge spanning the river at the height of Barikot. At the foot of the Shamozaï mountains, which enclose it at the sides and to the rear, it is located on a terrace with supporting walls, bounded on each side by two torrents. Behind it, at a higher level, are the ruins of a monastery and numerous other monuments, which are today partially occupied by the village. Further NE lies a vihara with a circular plan, still in reasonably good conditions, although destroyed in recent times. On the mountain slopes and jutting spurs other structures rise, large in size and well conserved (stupa, vihara, two-storey dwellings with stairways); a square shaped building with circular corner towers stands in isolation.

Bibliography and Documentation

The location was first visited and described by Stein in 1926. He reached it by crossing the river starting from the Guratai village. Stein examined the stupa (1930: 10, fig. 3, pl. 2 above) ⁽¹⁾ and mentions also the circular vihara (ibid.: 11, fig.

⁽¹⁾ 'Buddhist ruins of Gumbatūna — After more heavy rain during the evening and night the weather cleared sufficiently to permit of a move up the main valley. While our camp was sent on to Bīr-koṭ I proceeded from the village of Guratai to cross the wide belt of flooded rice fields between which the Swāt river flows in several interlacing beds, in order to visit the ruins reported at the small hamlet of Gumbatūna. As the name, the 'domes', had led me to expect, I found there a group of ruined Buddhist Stūpas nestling in a picturesque nook of the hillside which rises on the river's left bank close above the northernmost of its branches. On an artificially widened small plateau, some 80 feet above the alluvial flat, there rises a large but much injured Stūpa (fig. 3). By its side stands a massive square base badly broken which may have carried a Vihāra, while

5). The latter afforded the specific reason for Barger and Wright's visit (1941: 27) (see B4). Then Tucci (1958), who mentioned the special interest of the building with its corner towers, comparing it with the Udegram fortifications ⁽²⁾.

Inspection of the area and the stupa was carried out by Faccenna in 1960, accompanied by photos and sketches by V. Caroli and in 1966 by photographs by F Bonardi Tucci and sketches by T. Tamagnini.

In 1983 there was the visit of the Japanese Archeological Mission led by K. Nishikawa (Kyoto University Scientific Mission to Gandhara, 1986: 70, pl. 2.1).

In 1992 the area was excavated by the Department of Archaeology and Museums, Government of Pakistan led by Dr. M. Ashraf Khan, the then Curator of Swat Museum, Saidu Sharif (Khan Ashraf 1993: 44-46, pl. XI, figs. 26-27; extensively, 1996: 96-106, figs. 22-41, in particular, pp. 96-98, figs. 24-28) ⁽³⁾. Thanks to the

the remains of two small Stūpas could be traced to the north and south-east of the large one. The main Stūpa, of which pl. 2 shows a sketch plan and section, has the usual three bases, the lowest measuring 52 feet square, and a dome 34 feet in diameter. The total height when intact must have exceeded 45 feet. This Stūpa, like also the rest of the structures had been burrowed into, probably more than once. It had been cut all through from the east and a shaft 8 feet wide sunk down the centre from the top. In spite of the ravages of time and the hand of man, layers of hard cement-like plaster still survived in places on the surface of the dome and drum'.

⁽²⁾ 'If one fords the river at Barikot by means of the usual raft, one arrives at a site which is generally called Parrai: in the valley, on the lower slopes of the hills, ruins are very extensive and they grow in number in the locality Redawan and near the stūpa of Gumbatuna already described by Stein. Of special interest is a square building on the top of a hillock, with four round turrets at the four corners as in the fortifications of Udegram'.

⁽³⁾ 'The present salvage excavations at the sacred area were carried out by the Department of Archaeology, Government of Pakistan, under the direction of Dr. Muhammad Ashraf Khan, Curator, Archaeological Museum, Saidu Sharif, Swat in 1992, with participation of Mr. Shabir Hussain, Field Officer, and Mr. M. Aqleem, Foreman, Exploration Branch, Karachi.

'Location. The site of Gumbatuna [...] is a Buddhist establishment situated on the right bank of river Swat, six km west of Barikot village along the metalled road leading towards Nimogram in a wide valley. [...] A water spring gushes in the picturesque gully which is situated north of the sacred area. It seems to have been used both by the inhabitants and the pilgrims to the sacred place. The site is cut by two ravines which divided the ancient remains into three zones designated as zone A, B and C.

'Aims and Objectives of the Salvage Excavations. The objectives of the present excavations were to clear the site from approx. 7 meter thick deposit of debris left by the illegal diggers (pl. 5 fig. 22).

'The salvage digging was necessitated in view of the increasing clandestine activities of the antiquity hunters. The aim was to protect the remains and the hidden cultural contents from their further wreckage. In the proceedings selection of the Gumbatuna site was duly made in conformity with aims and objectives of the Gandhara Salvage Project. [...]

'Excavation. The excavations of the first season conducted in 1992, were limited only to zone B, lower terraces which comprised the colossal main stupa, votive stupas (pl. 5 fig. 23), pillars and several unidentified remains partially uncovered by the treasure hunters. The middle terrace is composed of an ancient walled-up terrace and some of the hovels of the hamlet now occupied by the modern village and mosque about 8 m above the stupa plateau. The upper terrace is 50 meters higher than the middle ones composed of different groups of monastic settlements, caves, viharas, and stupas.

'Zone B Lower Terrace (pl. 6 figs. 24-25). The excavation was undertaken on lower terrace which comprises the main stupa encompassed by the votive stupas. The columns of various shapes and sizes, which are lying in the area bounded by the enclosure wall. The lower terrace complex measures about 48x60 meters with an entrance from the east. The excavation followed the method of grid system by dividing the entire area in squares of 20x20 m. Three squares were marked alphabetically as A, B, C from north and then numbered in Roman from east to west. In order to uncover the layout of these buildings, horizontal excavations were carried out to various depths ranging from 4 to 7 meters. The structural remains of the lower terrace faced

generous kindness of Dr Ashraf Khan, to whom our sincere thanks are still due, Sabelli, Galanti and Mannari were able to make a survey of the stupa in 1992, part of which has been published to allow a comparison to be made with the Stupa of Saidu Sharif I (Faccenna 1995a: 504-15, Figs. 238-242, pls. 258-259). The sketches were re-ordered in Martore's graphic rendering, and new features added (axometry 1994; reconstruction plan view 2003).

Faccenna 1995b: 2, figs. 11-12.

Khan Ashraf and Lone 2004: 33 and fig. (4).

Photographic campaigns were carried out by Italian Archaeological Mission personnel or by collaborators or researchers. We recall here F. Bonardi 1965, 1966;

serious devastation in hands of the robbers. The clandestine diggings also destroyed the archaeological data by disturbing the remains and removing several valuable sculptures.

'Structural remains of the Main Stupa. The main stupa stands on a square plinth measuring 16 m each side with an offset projection 3.71 m long by 3.82 m wide for steps on the east (pl. 7 fig. 26).

'The gigantic stupa is probably the best preserved in ancient Uddiyana. It consisted of a dome, three lower drums, resting on a square podium and socle. The structure above the dome was comprised of harmika and umbrella, which are now missing. The umbrellas in various sizes, executed in plastered sand/schist stones with thick coat of lime, pieces of stone spacers of different size, pieces of stone columns fallen from their original situ, were noted in course of removal of the fallen debris, lying on the site (pl. 7 fig. 27).

'The stupa is square in plan and consists of base moulding on straight scotia pattern (h. 0.50 m). The podium or the square plinth rises to a height of 3.40 m from the top of the base moulding. The top of the plinth or podium is paved with slabs of schist from which projects a cornice (h. 0.35 m), built in corbelling fashion. It can still be seen on the western side. The Pradakshina Patha around the drum is paved with large stone slabs of schist of various sizes, and with a range of 0.20 m to 0.60 m.

'Around the base of the first drum on four corners, the square bases of four columns are still detectable which indicate that once the stupa was decorated with four columns. Such decorative elements were also noted at the stupas of Saidu and Najigram in Swat valley. The fallen pieces of these columns were found on the procession path, around the base moulding of the plinth of the stupa.

'The drum of the stupa is cylindrical in shape measuring 4.70 m in height and 13 m in diameter. It rises directly from the top of the plinth in three diminishing tiers, resting on an elaborate torus and scotia moulding and capped by cornice of over-lapping schist slabs (pl. 8 fig. 28). The drum is surmounted by a hemispherical shaped dome (height 4.80 m) which is 34 feet in diameter. It is cut all through from the east and 2 meters wide shaft was sunk down from the central portion of the top. The stupa is ascended by a flight of 12 steps on the east side leading to the top of the podium. The steps are in a dilapidated condition and the width of the structure of the stairway was recorded as 3.82 m (pl. 8 fig. 29). A floor level, paved with the help of schist stone slabs, circulated around the base moulding of the stupa plinth, thus enabling the pilgrims to conveniently circumambulate the stupa on the ground level.

'The Pradakshina Patha revealed two successive floors. The earlier floor is composed of compact mud with sand and small gravel. The second one is 0.02-0.05 m higher than the former. It slopes down slightly towards the east to ensure proper drainage of rain water. The discovery of two successive floors of the Pradakshina Patha suggested clearly two building periods of the stupa.

'The masonry of the main stupa is executed in diaper technique facing an interior core of rubble masonry. The diaper facing was originally covered by 2 cm thick coat of lime plaster mixed with minute pieces of small gravel, which can still be seen in some places.

'A large number of fragments of umbrellas and a large number of other pieces including spacers, bases of columns, stone and stucco figures with which the monument was originally adorned were recovered during cleaning operation of the Pradakshina Patha (pl. 9 fig. 30)'.⁽⁴⁾

⁽⁴⁾ 'Located on the right bank of the Swat River, 6 Km west of Barikot village along the metal road leading towards Nimogram. It is a Buddhist site consisting of a colossal Stupa with Viharas and votive Stupas. The salvage excavation conducted by Dr. M. Ashraf Khan, Department of Archaeology and Museums Pakistan in 1992. A large number of stone and stucco sculptures were recovered from the establishment. It belongs to 1st-3rd century AD'.

Taddei 1960; Faccenna 1960, 1966, 1992, 1993; Olivieri and Nascari 1993; Sabelli 1993; Kuwayama 1993; Rockwell 1994; Spagnesi 2005.

The Stupa

The centre is missing as far as the E wall, the top corroded, while the remaining part is reasonably well conserved. It remained in this condition over time, as is shown by a comparison with the previous documentation. It comprises the 1st storey, quadrangular in plan with stairway facing E, three circular storeys, the lower one with a diameter larger than the ones above, the first of which is the drum, and the composite dome, all of which have the same diameter. Columns were erected on the four corners of the 1st storey. The facing consists of rows of parallelepiped shaped, relatively small, blocks of fine-grained gneiss filled in on all four sides with an abundance of superimposed small slabs of the same material and with a variety of striated marble. The workmanship is accurate and precise. The core is composed of closely spaced large and small gneiss slabs, arranged in horizontal layers and bonded with clayey earth.

The material was quarried in the nearby mountain to the W, where traces of quarrying have been observed (Khan Ashraf 1996: 104).

1st Storey, Quadrangular in Plan

Height 3.67, with a length at the storey of 15.20 (N, S) x 14.55 (E, W), it has a base with a plinth made of blocks and slabs, torus and cavetto made of thin schist slabs, most of which missing, except for a short section on the W side composed of large and small slabs making up a projecting fillet, ovolo, reverse cavetto and fillet; the terminal part with its reverse ovolo and coping slab are missing but easily reconstructable. On the wall and base there are extensive traces of thick plaster (0.02). The wall plaster extends as far as the base and below the cornice; abutting it is the plaster of the mouldings applied at a later working stage using a well-known procedure. The plaster outlines the profile of the mouldings.

Aligned in the wall, at fairly regular distances apart, several gaps between the blocks are visible with a depth of 0.80-1.00. In the wall of the perforation there are some small slabs laid edgewise. They are, for example, in the S wall, in two rows, corresponding to the fifth and tenth row of blocks counting from below (0.80 above the base; distance between the two rows, 0.80). They may therefore be considered to have been executed deliberately, probably for the purpose of recessing beams using in the construction scaffolding (logput holes). This may be evidence of the fact that one of them on the N side was closed with its own plaster after the wall plaster had been applied.

A. Stupas

The stupa has a flight of steps with a projection facing E, the upper part of which and the steps are missing. It has a base, the same as the stupa, which continues along the sides of the projection and the ramp, terminating against the first steps. The ramp has been reconstructed with 15 steps and an inclination of 37° , ending with the riser against the projection interrupting its cornice.

The paving is made of wide schist slabs.

Alongside the stupa parts of chattravali disks and column elements (Khan Ashraf 1993: 97-98, pl. 7 fig. 27, pl. 9 fig. 30); some were already exposed (1966).

2nd Storey, Circular in Plan

Set back by 1.50 (N, S) and 1.31 (W) with respect to the 1st storey, with a diam. of 11.45 at the storey and a h. of 2.14, it has a base with plinth, torus and cavetto, composed in the same way as the 1st storey base. The upper part of the wall and cornice is missing, which probably repeated that of the one below. The height may be estimated on the basis of the 3rd storey springer.

The columns are supported by the storey and are conserved in the base plinth. The rear two are placed only a short distance (0.19) from the circular body of the stupa, closing the interior and exterior passages. Access was possible only in the front part where the front columns are 0.68 away from the stupa.

The schist slab pavement corresponds to the level of the plinth springer, which is laid directly on the monument core without any projecting slabs forming a supporting surface or foundation wall. Its height was later raised using a layer of schist slabs, subsequently covered with a layer of stucco about c. 0.30 from the top of the stupa plinth. This sequence is clearly visible in the NE corner between the column and base of the stupa as well as in the E section of the stupa; the stucco plane curves up to the plinth of both monuments. Pavements have been conserved also in the vicinity of the NW column and the stucco plane on the N side. Extensive plaster traces are visible on the wall and in particular on the stupa plinth.

3rd Storey, Circular in Plan (Drum)

Set back by 0.95 with respect to the storey below and constructed in the same way, with a h. of 1.54, it repeats the base with plinth, torus and cavetto and the cornice which, on the basis of the plaster traces, may be defined as having fillet, reverse cavetto and projecting, reverse ovolo. There are no coping slabs. Plaster traces are visible also on the base mouldings.

4th and 5th Storeys (Composite Dome)

4th Storey, Circular in Plan, Transition Element

It practically springs in line with the wall of the 3rd storey; it does not display a clear-cut curved profile at the top, tending towards the vertical; it has no base. The very narrow cornice is bracketed; it is composed of fillet, bracket, fillet and slab which may be constructed with a reverse ovolo profile; the coping slab is missing. The bracket is composed of a vertical slab with an indeterminable profile, probably with a reserve or with a cyma reversa; the bracket spacer is composed over superimposed small slabs, the top one projecting with respect to the others. The profile is completed with plaster in such a way that the bracket becomes wider than the bracket spacer with the upper fillet.

5th Storey, Raised Dome

Raised, with a springer at the level of the 4th storey wall, it is conserved up to a h. of 2.80 where the curvature begins; top part missing or lacking the facing. Extensive plaster traces.

SKETCH PLAN AND SECTION OF MAIN STUPA

GUMBATŪNA

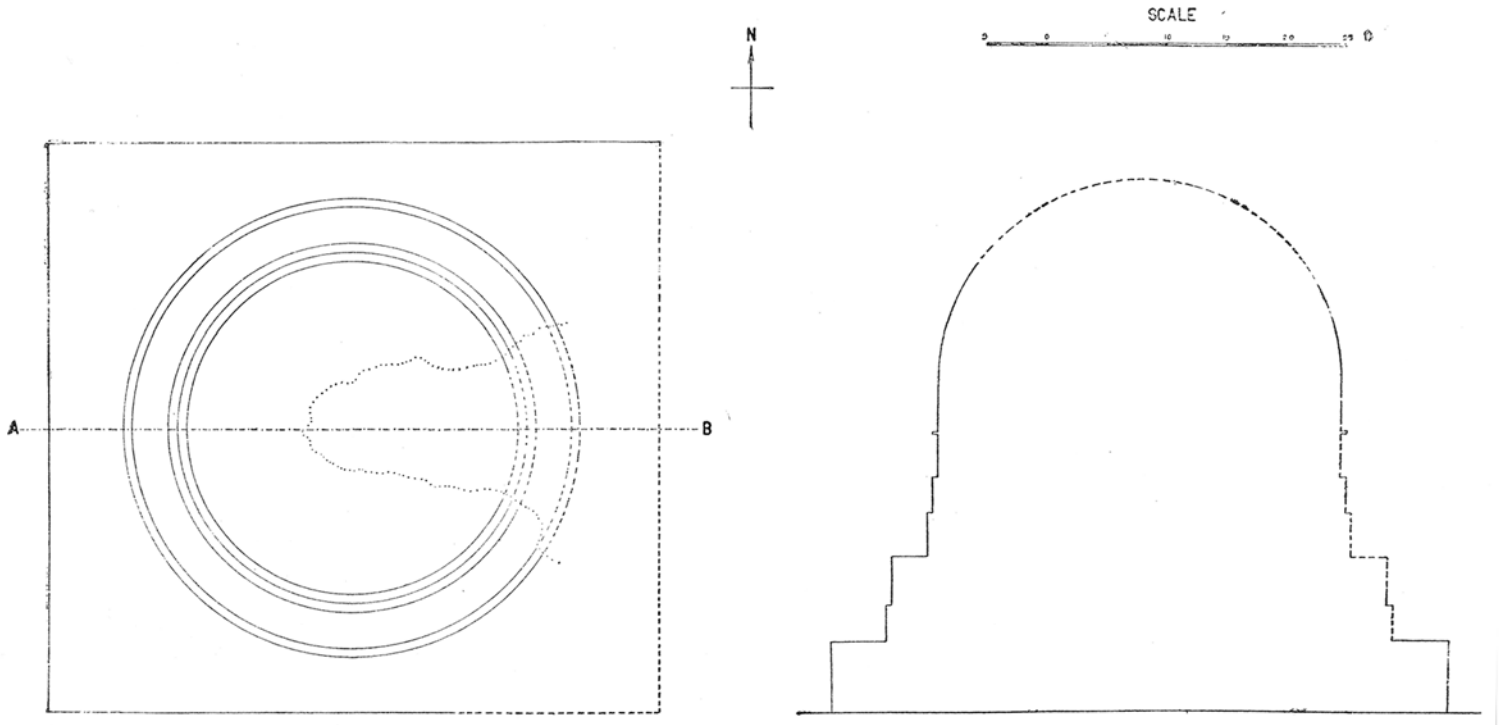

Fig. 415. Stupa of Gumbatuna. Sketch plan and cross section.
(After Stein 1930: pl. 2, at the top).

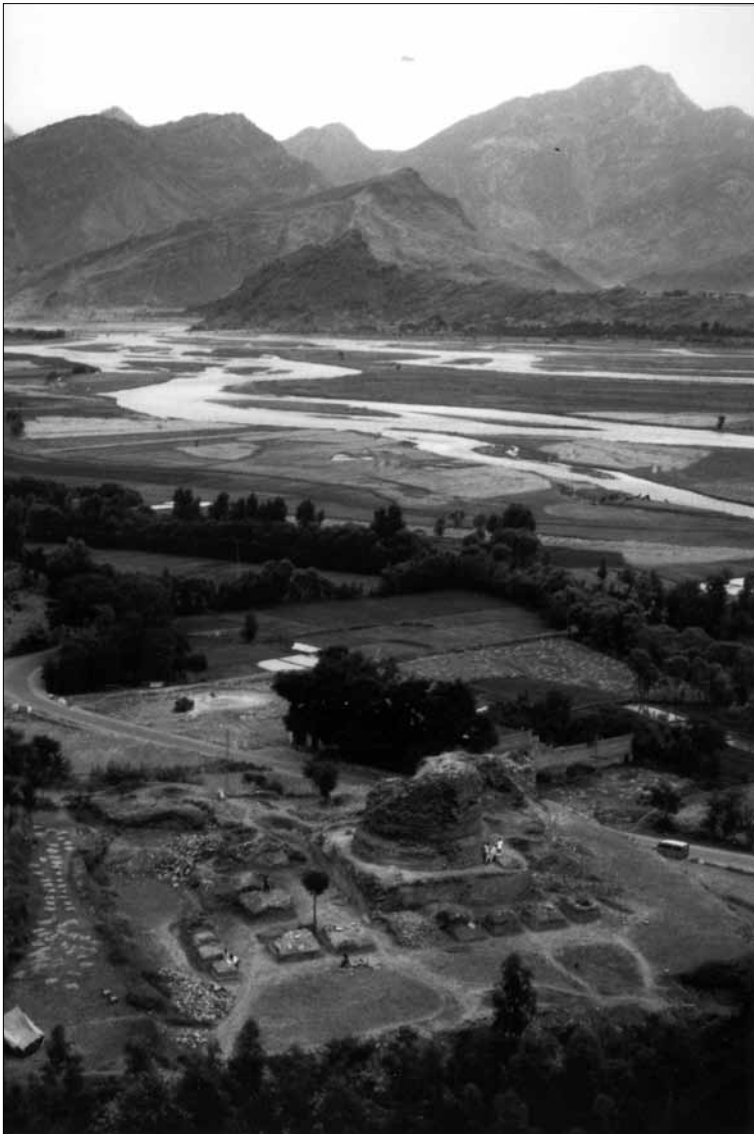

Fig. 416. Stupa of Gumbatuna. General view from NW to SW of the complex and the Swat valley; at the end of excavation. (Sabelli 1993).

A. Stupas



Fig. 417. Stupa of Gumbatuna. General view, E side, with stairway. (Kuwayama 1993).



Fig. 418. Stupa of Gumbatuna. General view, S side. (Kuwayama 1993).



Fig. 419. Stupa of Gumbatuna. 1st storey, corner moulding of the base. (Rockwell 1994; Neg. Cs).

A. Stupas



Fig. 420. Stupa of Gumbatuna. 1st storey, plinth of the pedestal of the NE corner column. (Kuwayama 1993).

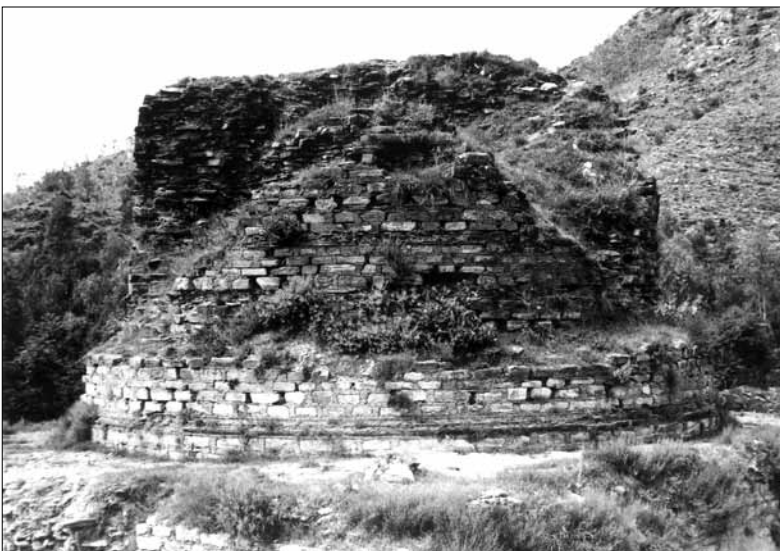

Fig. 421. Stupa of Gumbatuna. General view, E side; 2nd, 3rd, 4th and 5th storey. (Rockwell 1994; Neg. CS).



Fig. 422. Stupa of Gumbatuna. SE side; 3rd storey (drum), 4th storey (transition storey of the composite dome) with cornices. (Bonardi Tucci 1966; Neg. CS).



Fig. 423. Stupa of Gumbatuna. SE side; 3rd storey (drum), 4th storey (transition storey of the composite dome). (Bonardi Tucci 1966; Neg. CS).

A. Stupas



Fig. 424. Stupa of Gumbatuna. SE side; 4th storey (transition storey of the composite dome) and cornice, detail. (Sabelli 1993; Neg. CS).



Fig. 425. Stupa of Gumbatuna. A probable chattravali element. (Nascari 1993).

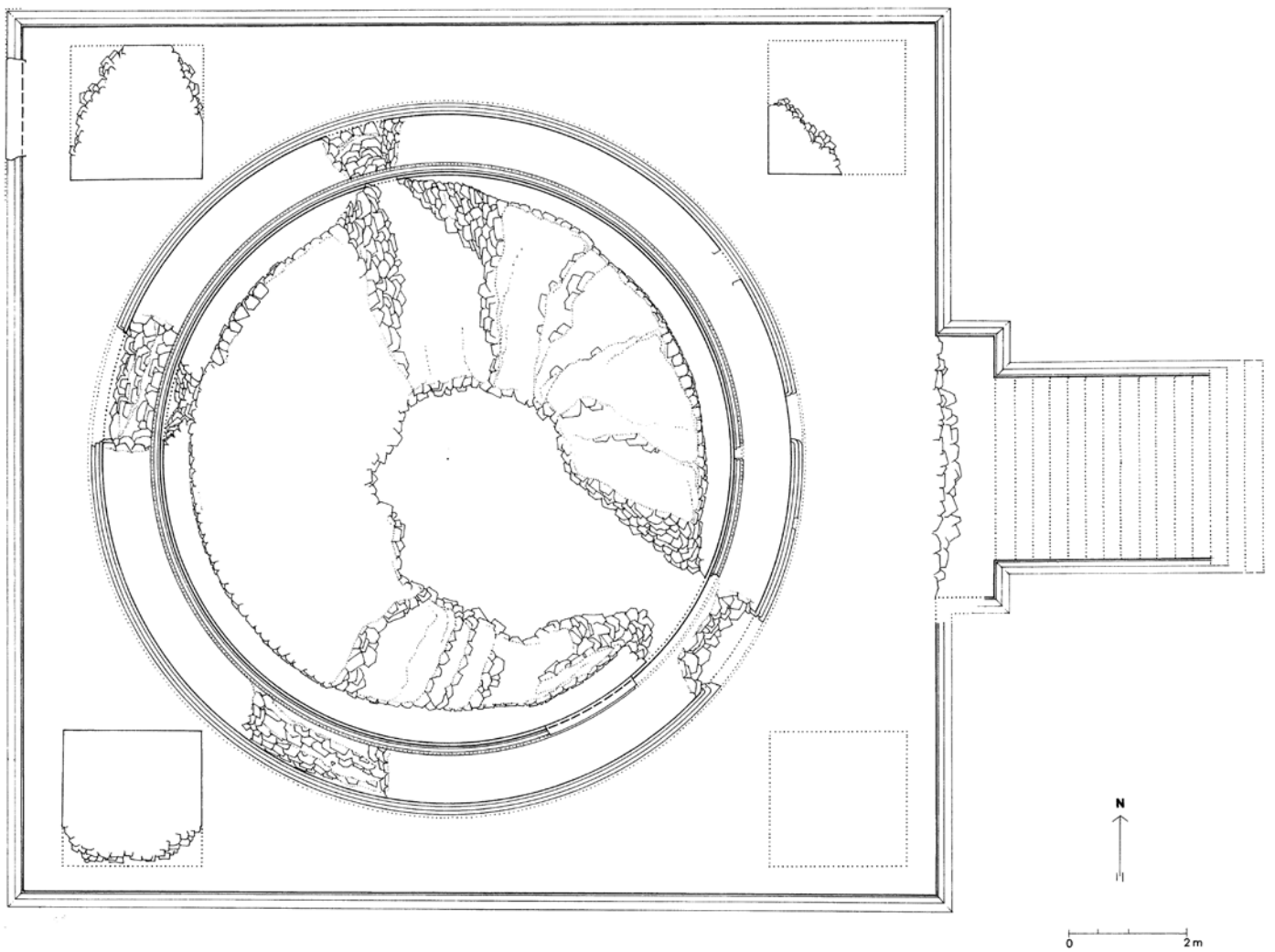

Fig. 426. Stupa of Gumbatuna. Plan. (Sabelli 1993; Martore 1994).

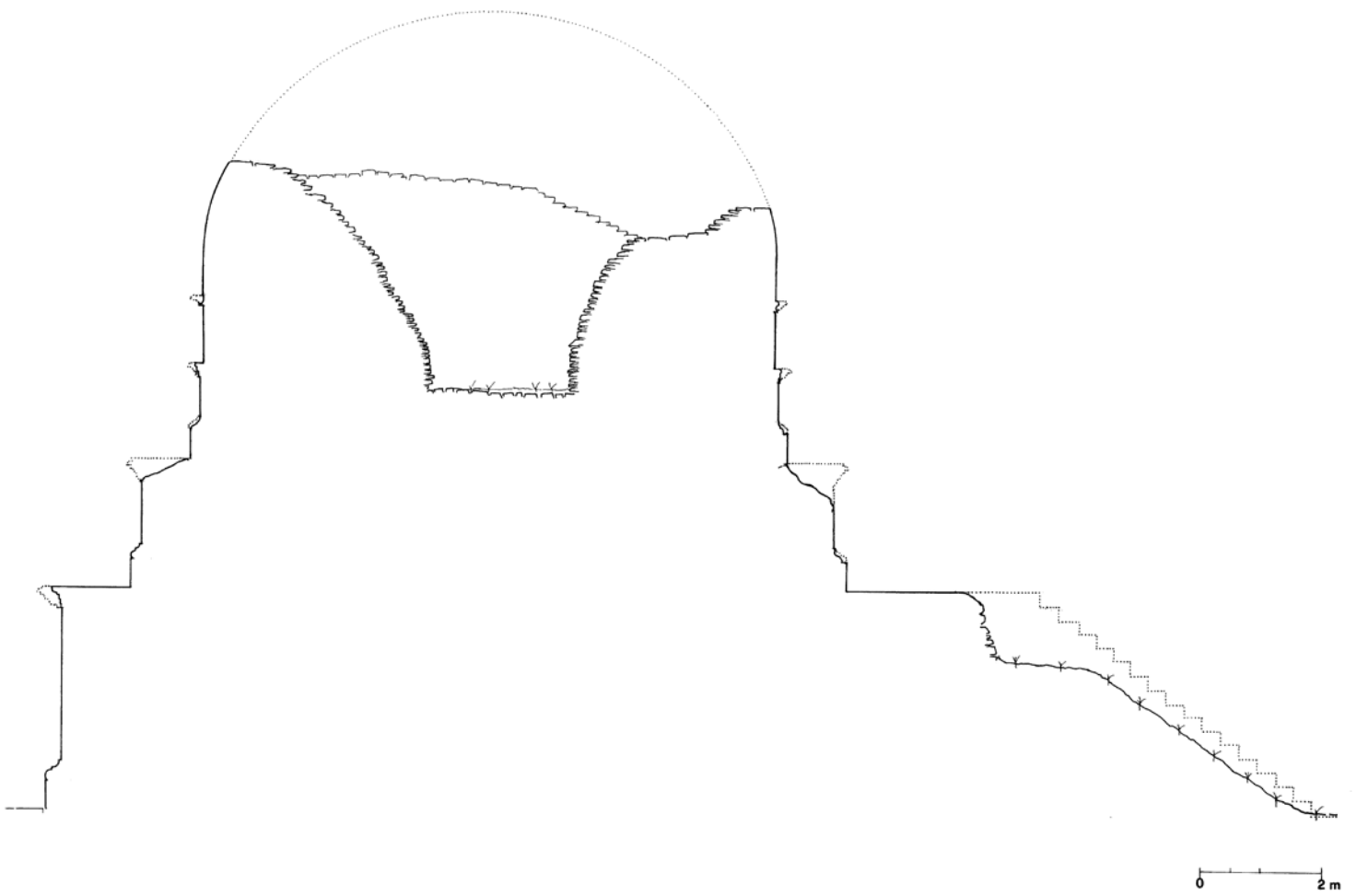

Fig. 427. Stupa of Gumbatuna. E-W cross section. (Sabelli 1993; Martore 1994).

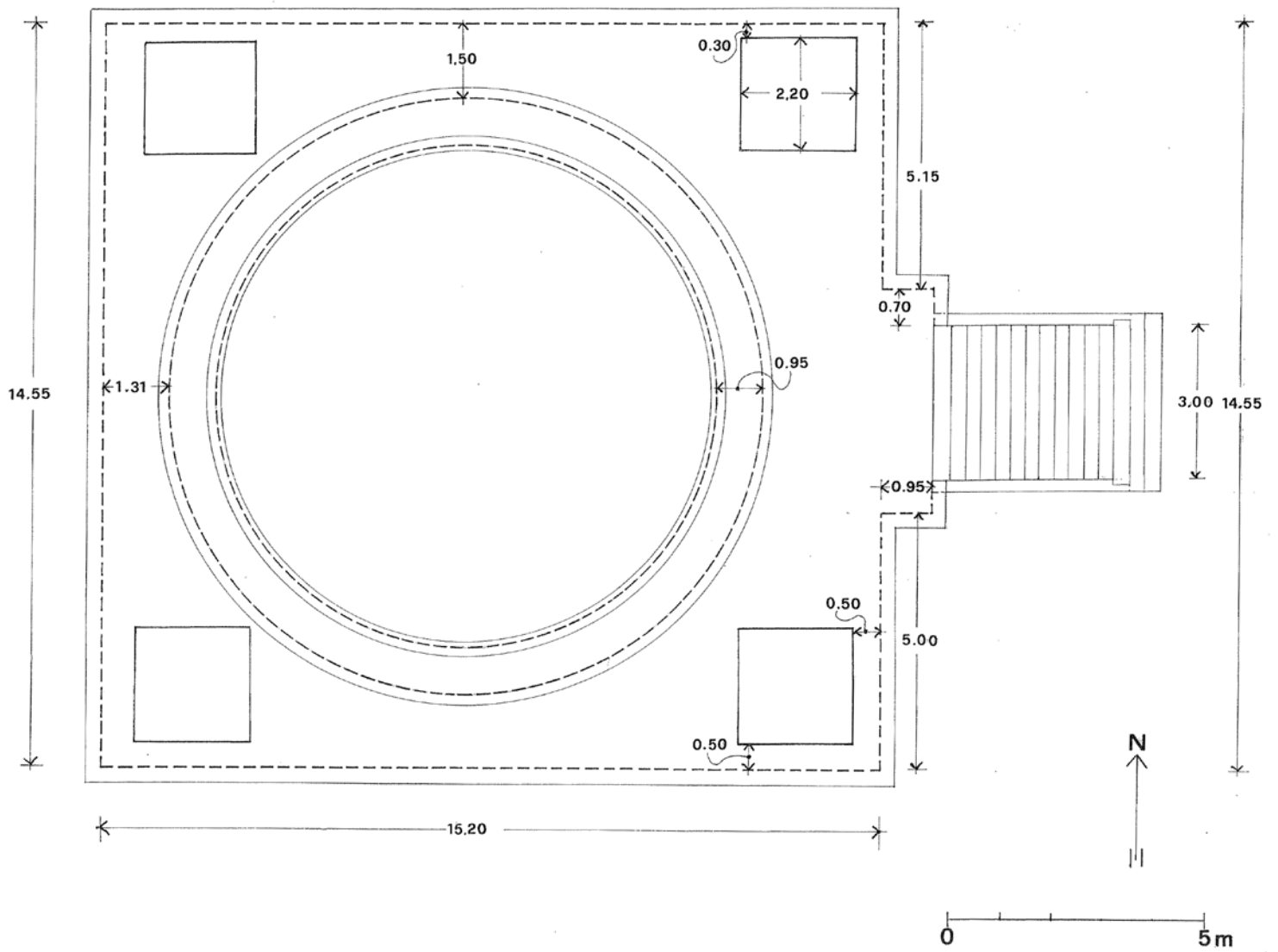

Fig. 428. Stupa of Gumbatuna. Sketch plan showing the measures. (Sabelli 1992, 1993; Martore 1994).

A. Stupas

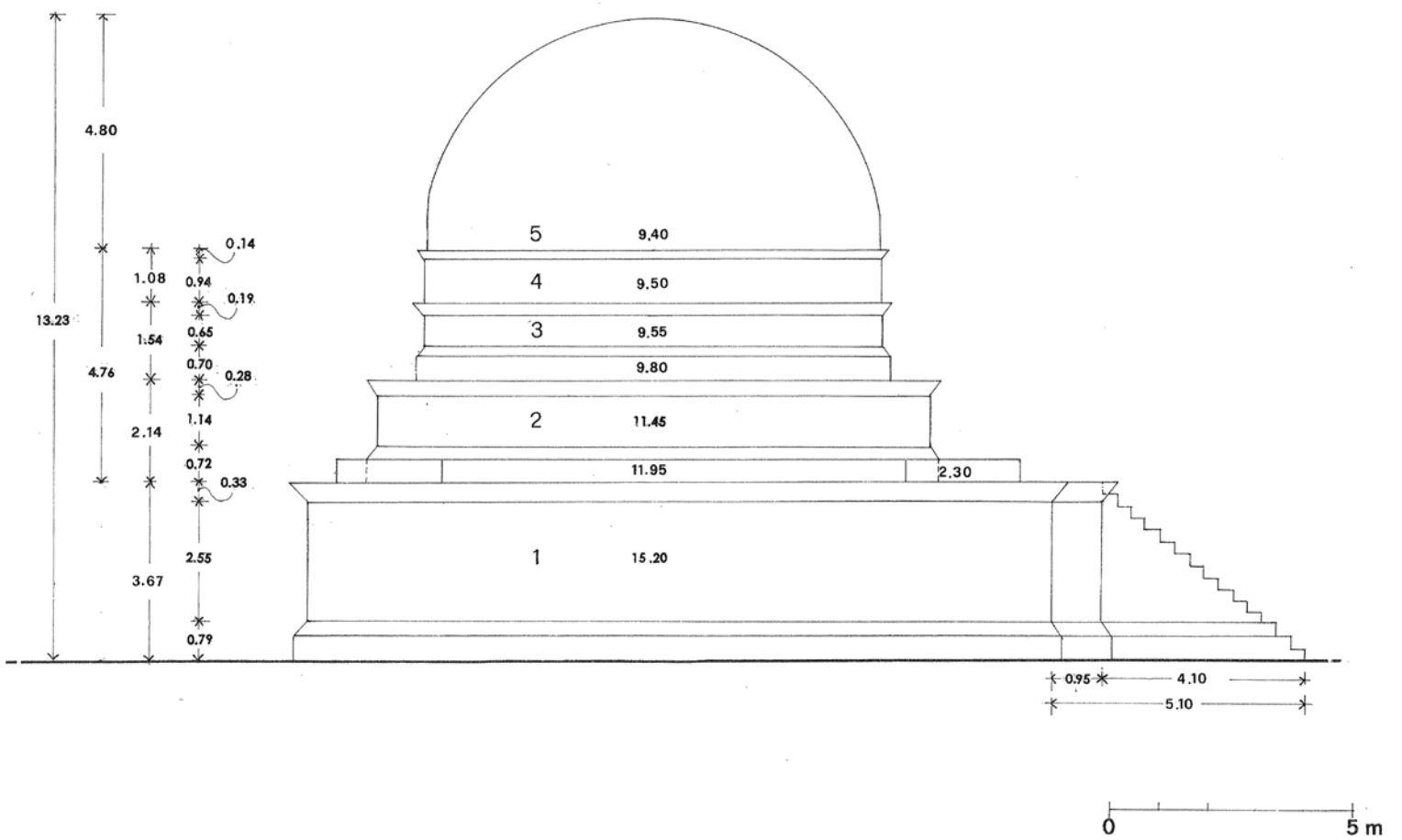

Fig. 429. Stupa of Gumbatuna. Sketch elevation showing the measures. (Sabelli 1992; Martore 1994).

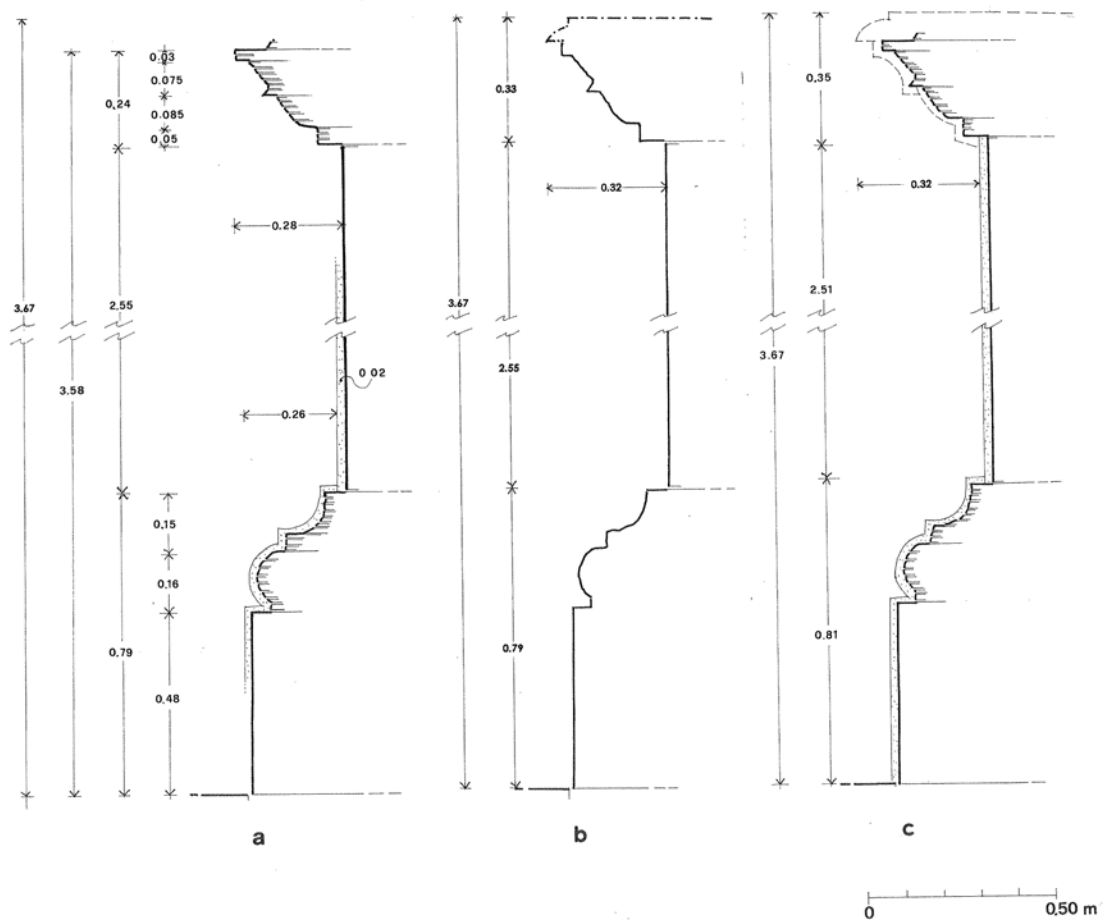

Fig. 430. Stupa of Gumbatuna. 1st storey. *a.* profile. *b.* reconstructed profile, without plaster. *c.* reconstructed profile, with plaster. (Sabelli 1992; Martore 1994).

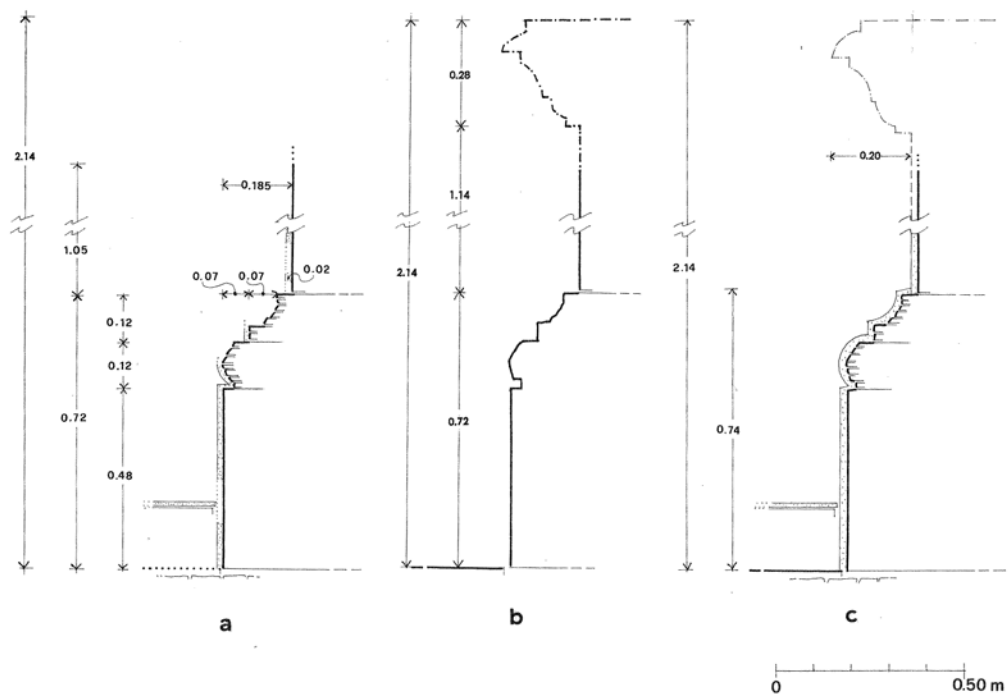

Fig. 431. Stupa of Gumbatuna. 2nd storey. *a.* profile. *b.* reconstructed profile, without plaster. *c.* reconstructed profile, with plaster. (Sabelli 1992; Martore 1994).

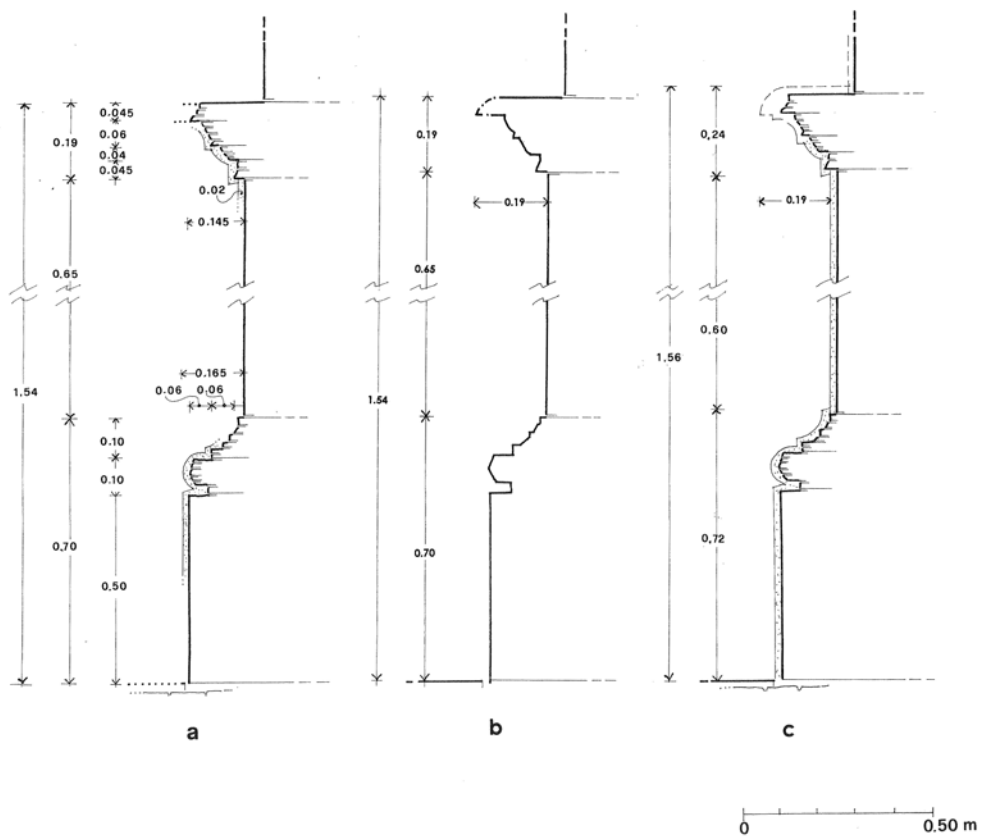

Fig. 432. Stupa of Gumbatuna. 3rd storey (drum). *a.* profile. *b.* reconstructed profile, without plaster. *c.* reconstructed profile, with plaster. (Sabelli 1992; Martore 1994).

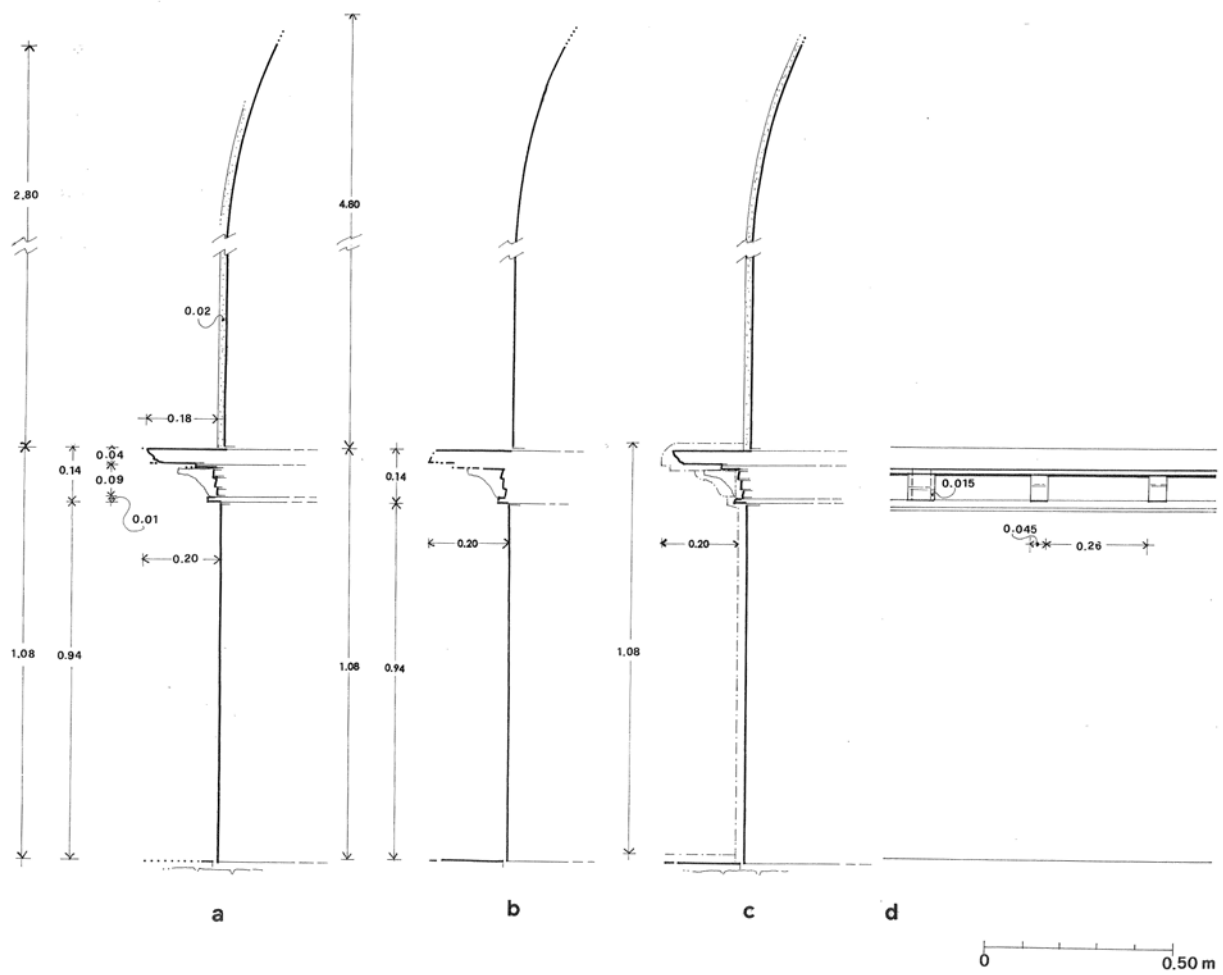

Fig. 433. Stupa of Gumbatuna. Composite dome of the 4th transition storey and 5th storey with raised dome. *a.* profile. *b.* reconstructed profile, without plaster. *c.* reconstructed profile, with plaster. *d.* elevation of the 4th storey with cornice and brackets. (Sabelli 1992; Martore 1994).

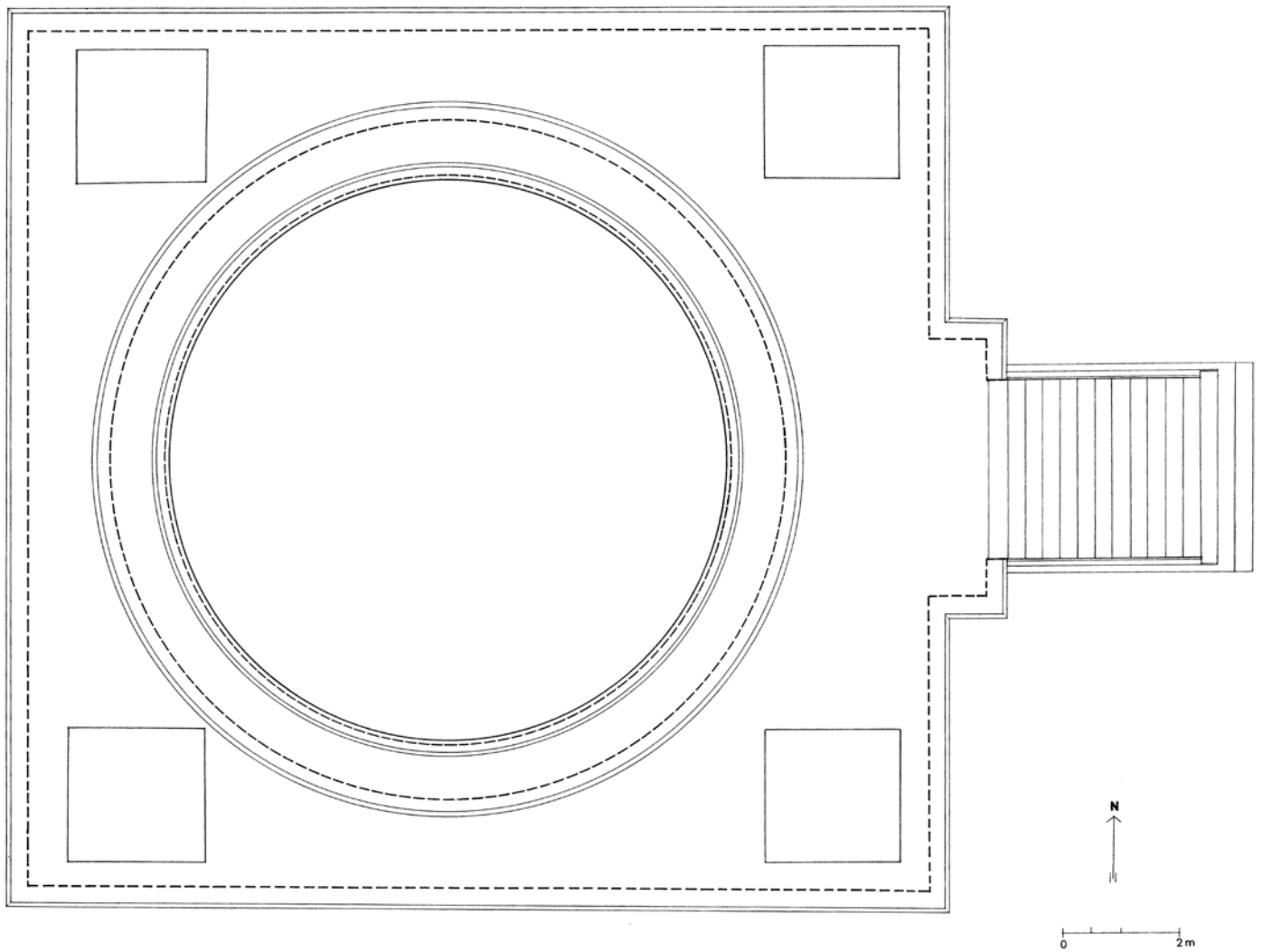

Fig. 434. Stupa of Gumbatuna. Reconstructed plan. (Sabelli 1992; Martore 1994).

A. Stupas

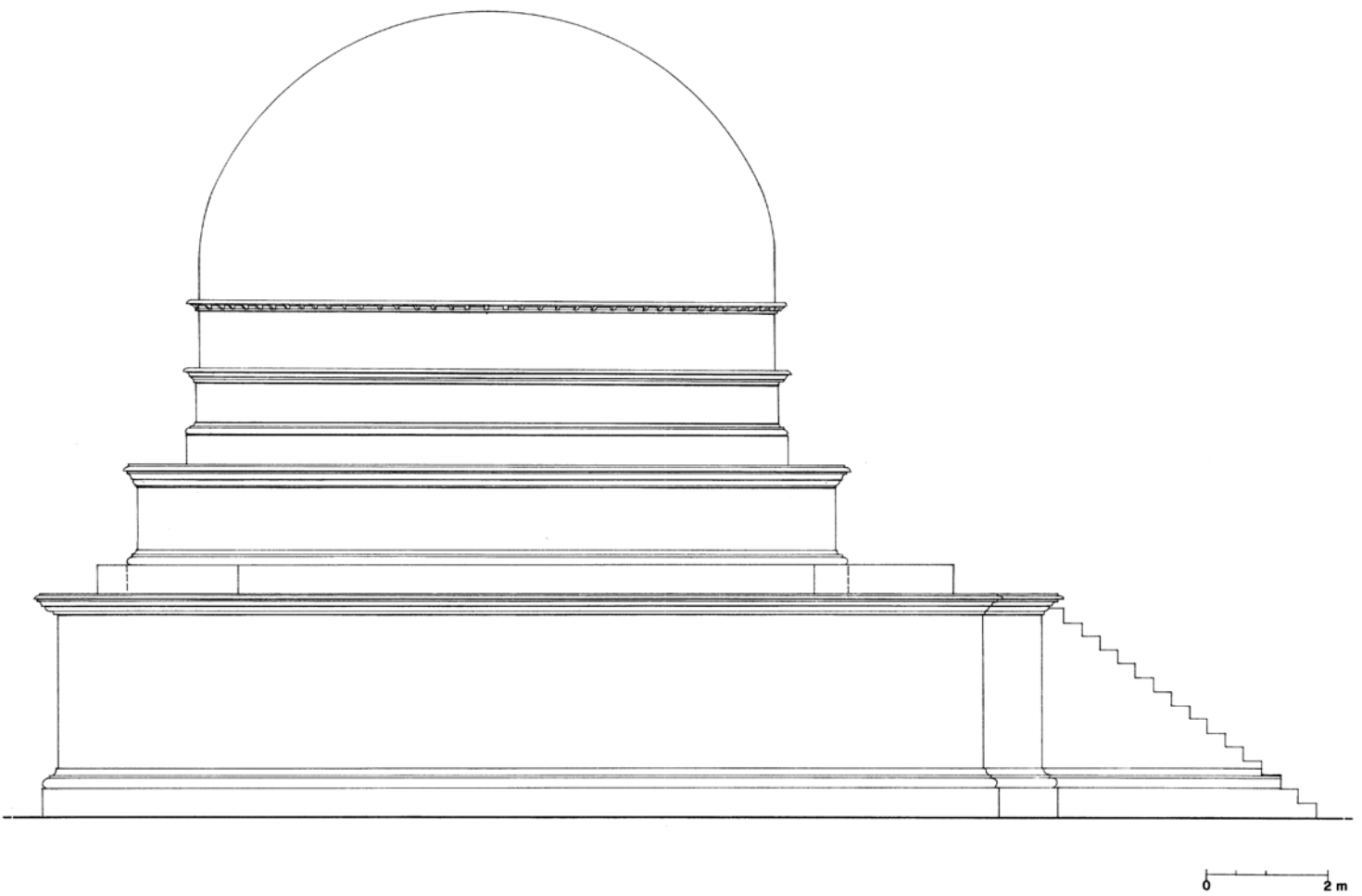

Fig. 435. Stupa of Gumbatuna. Reconstructed elevation. (Sabelli 1993; Martore 1994).

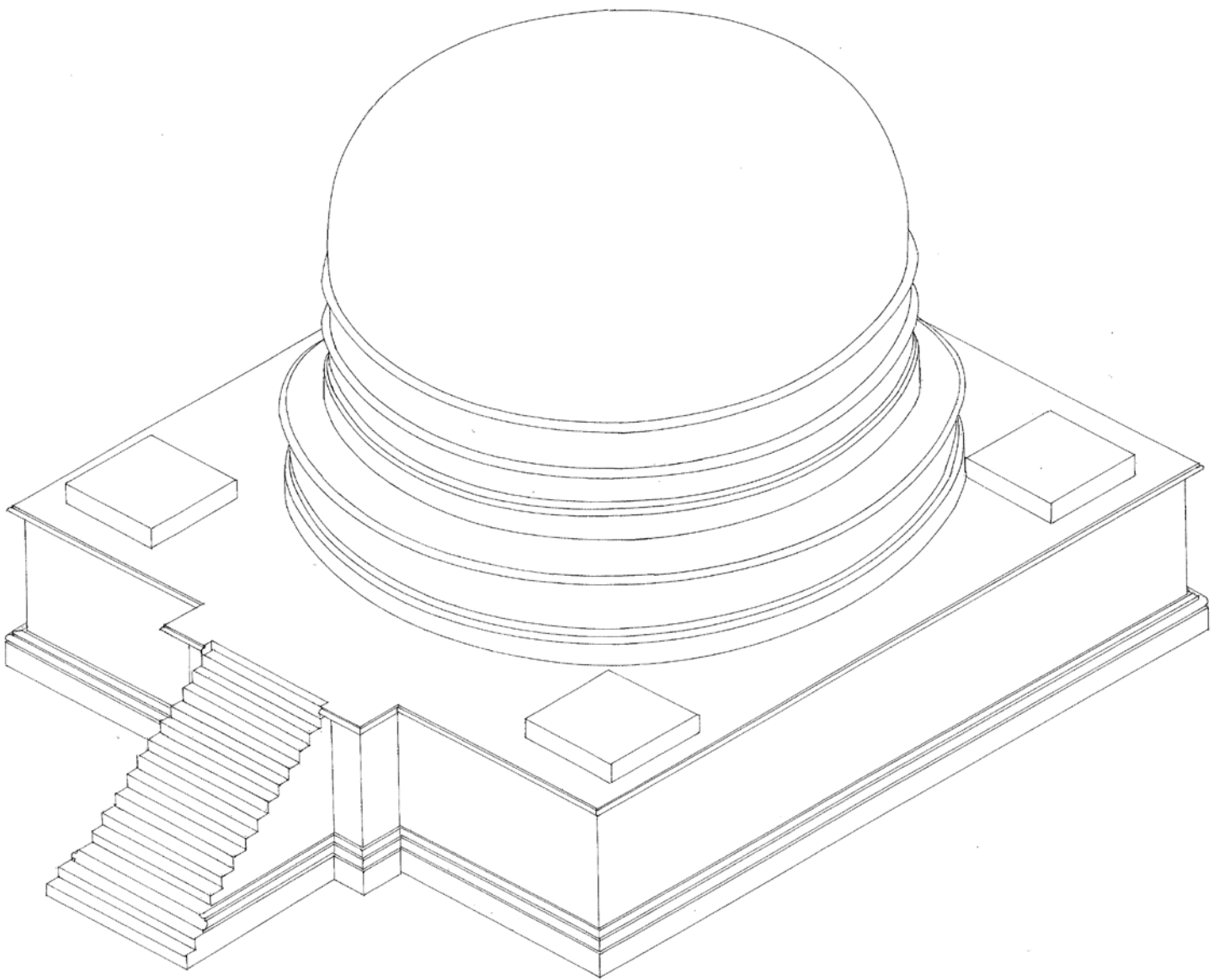

Fig. 436. Stupa of Gumbatuna. Axonometric view. (Martore 1994).

B.

VIHARAS

The vihara ⁽¹⁾ is widely used. A description and a graphic and photographic representation is given of several of them owing to their interesting conditions of conservation or for the opposite reason – namely that, as they have been wholly or partially lost, their memory remains in the documentation collected in past years.

They are:

Zone of Barikot

B1 Vihara of Abbasahebchina

B1.1 Vihara F

B1.2 Small vihara

B2 Vihara of Gumbat

B3 Vihara of Kanjar Kote

B3.1 Double vihara

B3.2 Vihara, circular in plan

Zone of Gumbatuna

B4 Vihara of Gumbatuna

⁽¹⁾ For the conventional use of this term, see Faccenna & Filigenzi 2007: 53-54.

B1. Vihara of Abbasahebchina

B1.1. Vihara F

(Figs. 437-454)

The Site

Zone of Barikot.

Position: Lat. 34° 37'N; Long. 72° 13'E; SPM 43 B/2.

Located in the S zone of the area on the left bank of the torrent in front of stupa B; it is quite well conserved, with podium, aedicula, double roof covering and opening to the N. Supported by a substruction wall. For its position in the complex see no. 10, the stupas of Abbasahebchina.

Bibliography and Documentation

Barger & Wright 1944: 25.

Tucci 1958: 318, fig. 33 on p. 315 (survey, plan and elevation by Caroli).

Faccenna 1957: graphic survey by V. Caroli and photographic reconnaissance.

Taddei and Scerrato 1958: photographic reconnaissance.

Gui and Cimmino 1965: graphic survey and photographic reconnaissance.

Photographic campaigns were carried out by Italian Archaeological Mission staff or researchers: Mariani 1968; De Marco 1983; Nascari 1991-92; Kuwayama 1993.

In 1993, graphic survey with photographic reconnaissance by Sabelli, followed in 2003 by Martore's intervention.

This was followed by Behrendt 2004 with an inspection and photographic reconnaissance; Olivieri and Vidale 2004; Spagnesi 2005: reconnaissance and photographic campaign; Faccenna 2005: 92, fig. 14.

The site has been included in the Archaeological Map of the Swat Valley (Olivieri & Vidale 2006: 100).

Spagnesi 2006: 162, figs. 9-11.

The Vihara

Supporting Structures

In order to offset the differences in ground level, which rises from E to W, a retaining wall was built so as to form a level area for building, on which the vihara now stands. The wall is made of fairly regular blocks with a roughly finished external face; h. 0.70. It abuts another structure, lower down, made of large, rough-hewn blocks, visible for a distance of 1.00 (1957).

Podium (A)

The podium h. is 1.905, measuring 4.80 x 4.74 in plan at the wall level; it has a scotia type base with tall plinth, scotia with carinated lower torus composed of two slabs and an upper one consisting of one slab, and cavetto with progressively receding fillets. The wall consists of three rows of blocks and small slabs. The corbelled cornice has an ovolo between two fillets, each obtained from a slab, a bracket composed of one small vertical slab; this is followed by two rows of slabs with a receding cut forming a fillet; three protruding slabs, which gradually recede to form a reverse ovolo and coping slab.

Aedicula (B)

It is 3.73 high with a rectangular plan diverging slightly in front (4.80 x 4.74 x 4.94 in front); three walls have been conserved (thickn. 0.72) the two lateral ones of which having a slightly inward inclination at the top; the fourth one, in front, with the entrance, is completely missing. The heads of the two side walls are so badly damaged that no signs of any antas are visible: several blocks seem to extend beyond the line of calculated wall thickness but may possibly be considered toothings; also a hole in the E wall, perhaps a putlog hole, may have been executed from outside in the thickness of the wall, independently of the wing. The corroded threshold does not provide any other evidence.

The cell plane is obtained using small internal slabs projecting from the wall and forming part of the podium core; the floor has been completely lost, together with the threshold. The cell measures 4.05 in depth, 3.30 in width at the back and 3.50 at the front.

In the back wall, at the centre of its width and at a height of 2.10 above the

paving there is a small opening or window (h. 0.28, width 0.18); the holes at the sides and on top are putlog holes used during the construction work. Three are visible in the E wall and the same number in the W wall, all at the same level.

The front part of the podium is partly ruined and most of it has been buried. Probably the podium wall continued in a straight line on the front with a base and cornice. The vihara thus lacked a stairway of its own. The absence of the latter does not represent an obstacle to access.

On top, on the outside, the walls end in a cornice composed of an ovolo between two fillets, bracket with straight cyma (?) and above a thick fillet made by three rows of slabs. The cornice probably continued on the front part of the entrance.

The entrance is 3.50 wide at the base, and 3.40 at the top, thus forming a weak point in the structure, as is proved by the collapse that occurred in this part of the building.

Lower Roof Covering (C)

The roof covering, which projects from the aedicula cornice, rises with curved slopes, three of which (E, W, S) have been conserved; the fourth, on the N front, is missing, and terminates on top with a series of receding slabs; built using blocks and small slabs.

Inside the dome (F), circular in plan, it displays a band projecting from the wall which runs round the corners, supported by large circularly shaped slabs; the band is closed by a short cornice consisting of an ovolo (two slabs) between a lower fillet and two upper ones. Then continuing the line of the band it rises with gradually projecting slabs hollowed out so as to fit together. It has an ogival profile; the top was closed and reached as far as the level of the upper dome.

On the now missing front side it is not certain how the roof covering appeared on the outside. While the space does not seem to be sufficient for a fourth bend it is quite conceivable that on this side the covering nevertheless continued forwards, and was cut off at the end, resting on the straight architrave.

Intermediate Body (D)

On top of the roof covering is a U shaped storey with the extremities open on the front. It has a width of 4.00 and an ovolo type cornice.

Upper Roof Covering (E)

It stands on the intermediate body; it juts out, supported by a slab with a series of superimposed small slabs, continuing with a facing of blocks and small slabs. It should be noted that the gap that occasionally appears as a band above the springer slab is due to the absence of material and not the absence of projecting slabs in the form of a cornice, as observed elsewhere.

It is curved on the S side and straight on the E and W sides; the front part is missing. The straight line continues beyond the median E-W axis; this seems to indicate that this covering continued straight on as far as the front where it terminated abruptly. Also the upper part is missing and is indeterminable.

In plan view the rear curved part extends towards the front, following the line of the intermediate body and of the lower roof covering.

The double roof covering of the vihara takes on a truncated shape in front, as is found in other examples in Takht-i-Bahi (Foucher 1905: 124-26, fig. 46). This is the motif found in arches, aedicula fronts, pseudo-niches with pseudo trilobate arches.

Traces of plaster are visible on the external walls, especially on the S side.

Entrance Plan (F)

The viharas and stupas aligned along this side are situated on a terrace provided with a long substruction wall. Access to it is provided through the lower storey by means of a ramp of steps in the N corner supported by a wall forming a blunt angle. There must have been the same ramp on the S side running round below the vihara and on the front. The springer of F is situated at -1.05 versus the impost of the stupa B (see Fig. 222 with the partial planimetry surveyed at Abbasahechina).

Reconstruction

The double roof covering truncated vertically on the front is reminiscent of both the structure plainly visible at Takht-i-Bahi and the pseudo niches.

It was certainly bounded by a protruding arched lintel.

In the reconstruction a neutral form has been maintained; the outer profile of the upper covering has been rendered on the basis of the profile of the curve of the inner vault.

Brown's reconstruction (1976⁷: pl. XXXIII) of the Takht-i-Bahi monument gives an idea of the overall picture of the courtyard area. We have rendered the upper part using a roof covering with a much simplified profile and the upper covering with a pointed arch (and not a four-centred arch as in Brown).

B1.2. Small Vihara (Fig. 455)

In the description of the central complex with the stupas (no. A10) mention was made of the viharas erected inside it (vihara D, vihara M1-M4) to maintain a unified architectural view.

We now describe a 'small vihara' just S of a stupa, both situated outside the central complex.

Practically standing opposite the stupa described above, it was built on a flat rocky area. It has a simple quadrangular plan, the cell of which (3.00 x 2.90) has a slightly curved rear wall corresponding to the external wall running in a curved off-centre fashion; it has a roof covering with antas, facing N.

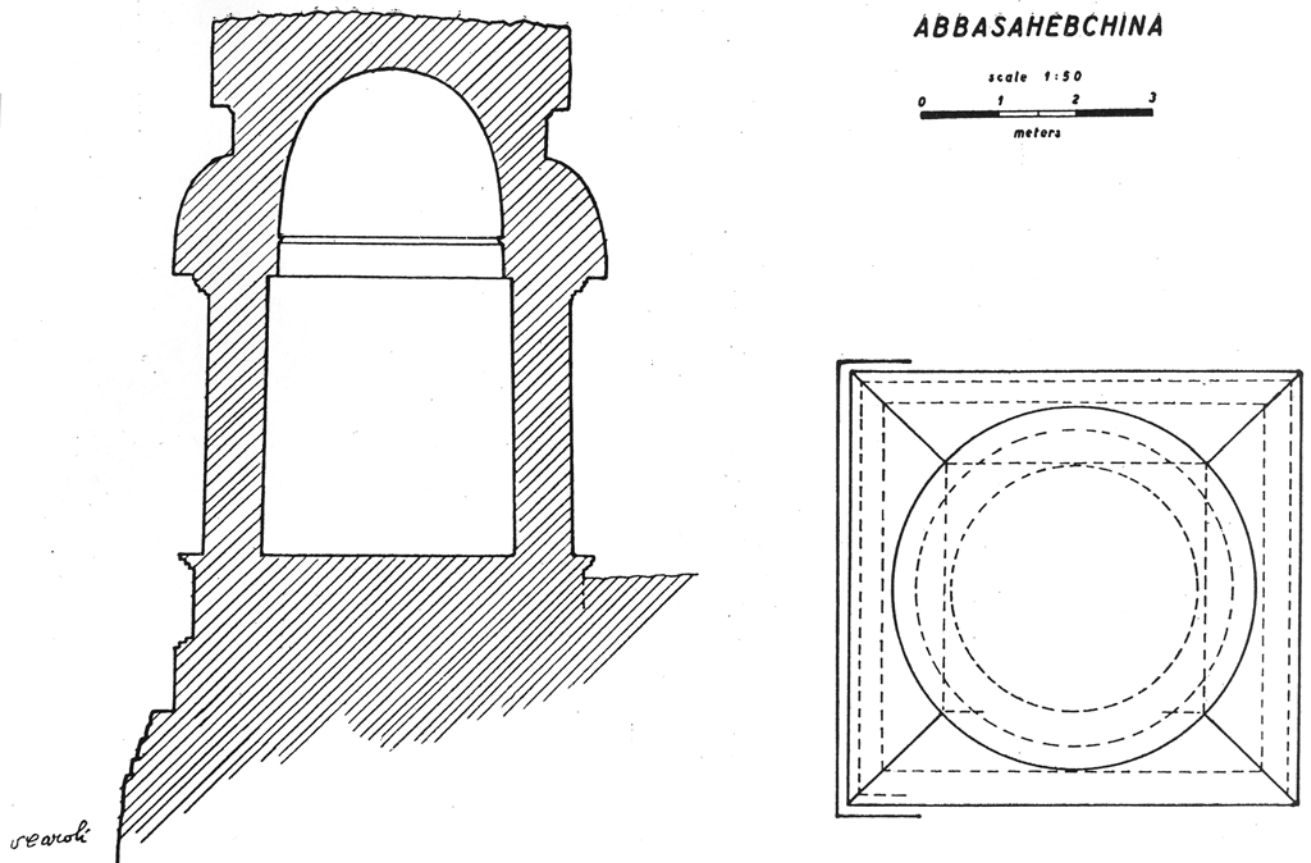

Fig. 437. Abbasahebchina, vihara F. Plan and elevation. (After Tucci 1958: fig. 33; drawing by V. Caroli).

B. Viharas



Fig. 438.
Abbasahebchina,
vihara F General
view with
monuments (vihara
D, Stupa C in
the background).
(Taddei 1957; Neg.
CS).



Fig. 439. Abbasahebchina, vihara F E side. (Spagnesi 2005).



Fig. 440. Abbashehchina, vihara F S side. (Spagnesi 2005).



Fig. 441. Abbasahebchina, vihara F S side, detail of the cornice. (Spagnesi 2005).



Fig. 442. Abbasahebchina, vihara F W side. (Taddei 1957; Neg. CS).



Fig. 443. Abbasahebchina, vihara F Detail of W and S sides of the two domes and transition storey (C, D, E). (Gui and Cimmino 1965; Neg. CS).



Fig. 444. Abbasahbchina, vihara F N side (frontal) with the entrance and inside of the aedicula. (Taddei 1957; Neg. CS).

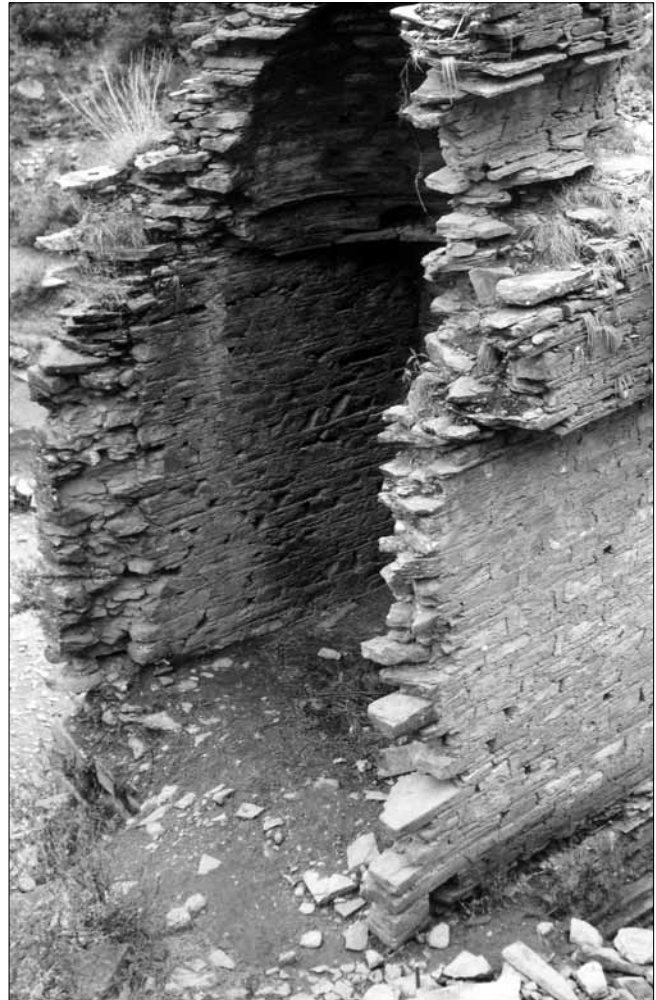

Fig. 445. Abbasahbchina, vihara F N side (frontal) with the entrance and inside of the aedicula. (Gui and Cimmino 1965).



Fig. 446. Abbashechina, vihara F Inside of the aedicula (B); lower dome with springer on corner slabs and overlying band (F, G). (Kuwayama 1993).

B. Viharas



Fig. 447. Abbasahebchina, vihara F. Inside the aedicula (B); dome springer lying on slabs; detail of SW side with corner slabs and overlying band (F, G). (Taddei 1957; Neg. CS).



Fig. 448. Takht-i-Bahi. Courtyard. (Taddei 1958; Neg. CS).

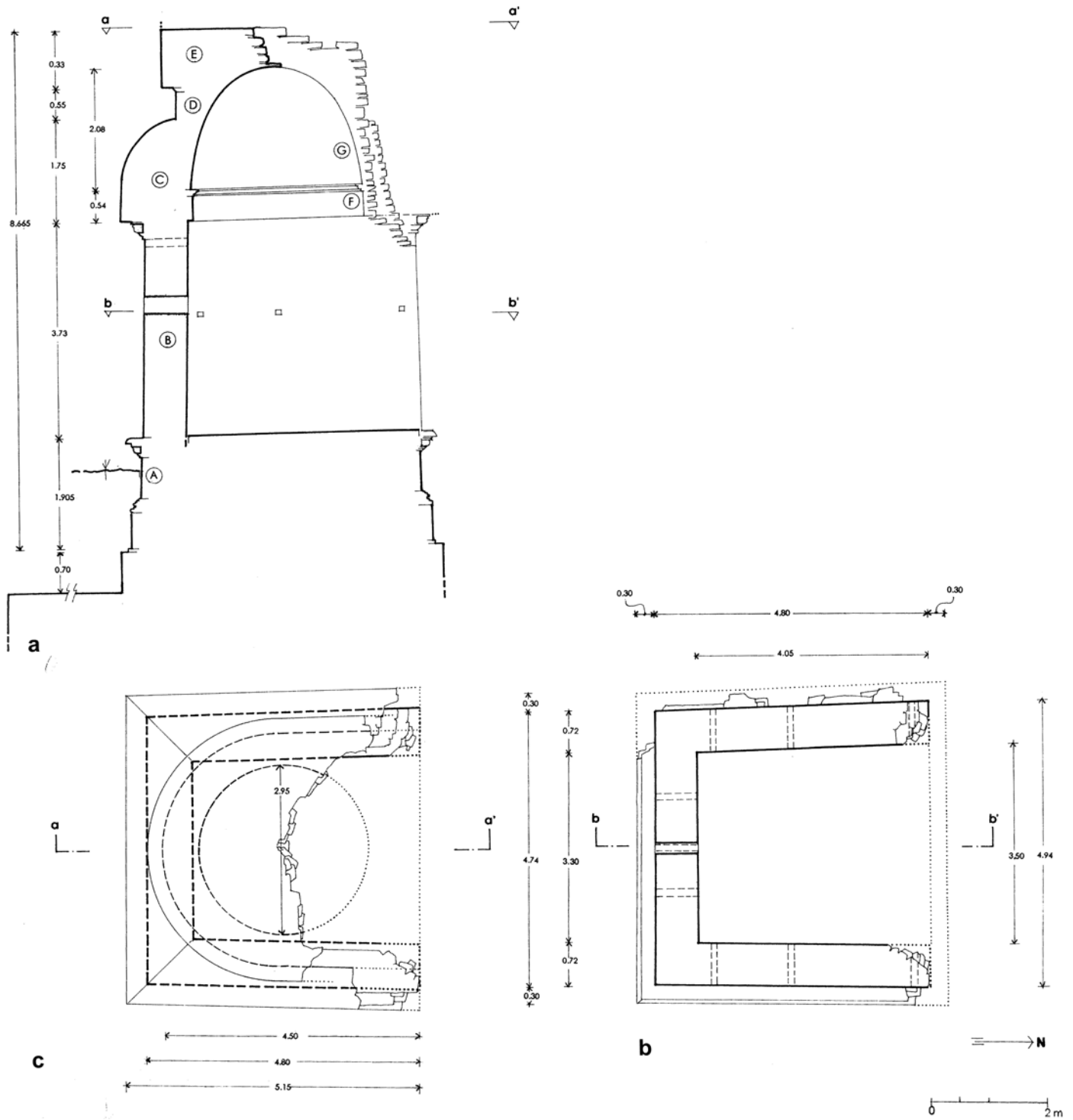

Fig. 449. Abbashehchina, vihara F. a. N-S cross section showing the measures; b, c. plan, on the level of the aedicula and the upper dome. (Sabelli 1993; Martore 2003).

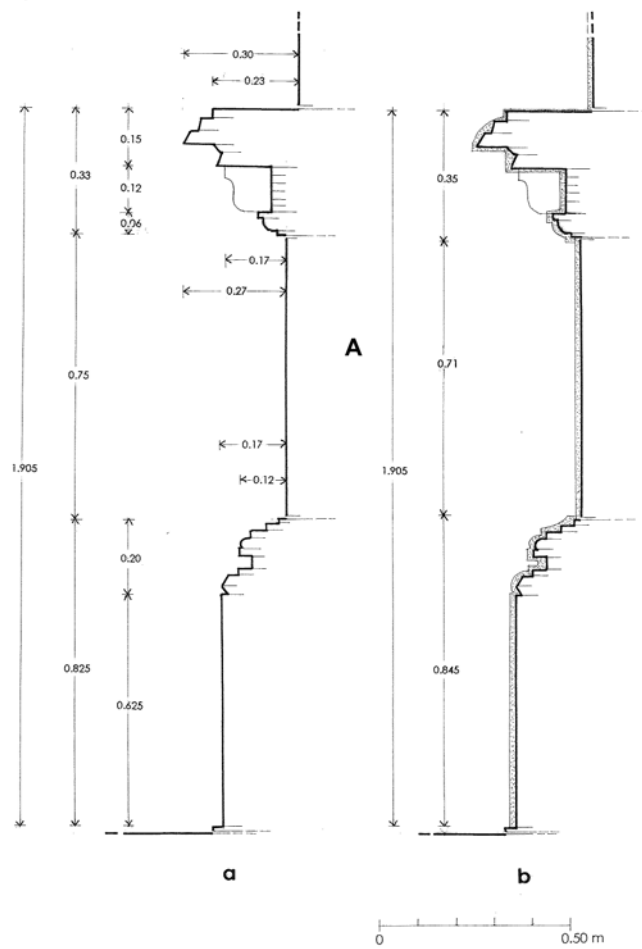

Fig. 450. Abbasahchina, vihara F Podium (A). a. profile, without plaster. b. profile, with plaster; showing the measures. (Sabelli 1993; Martore 2003).

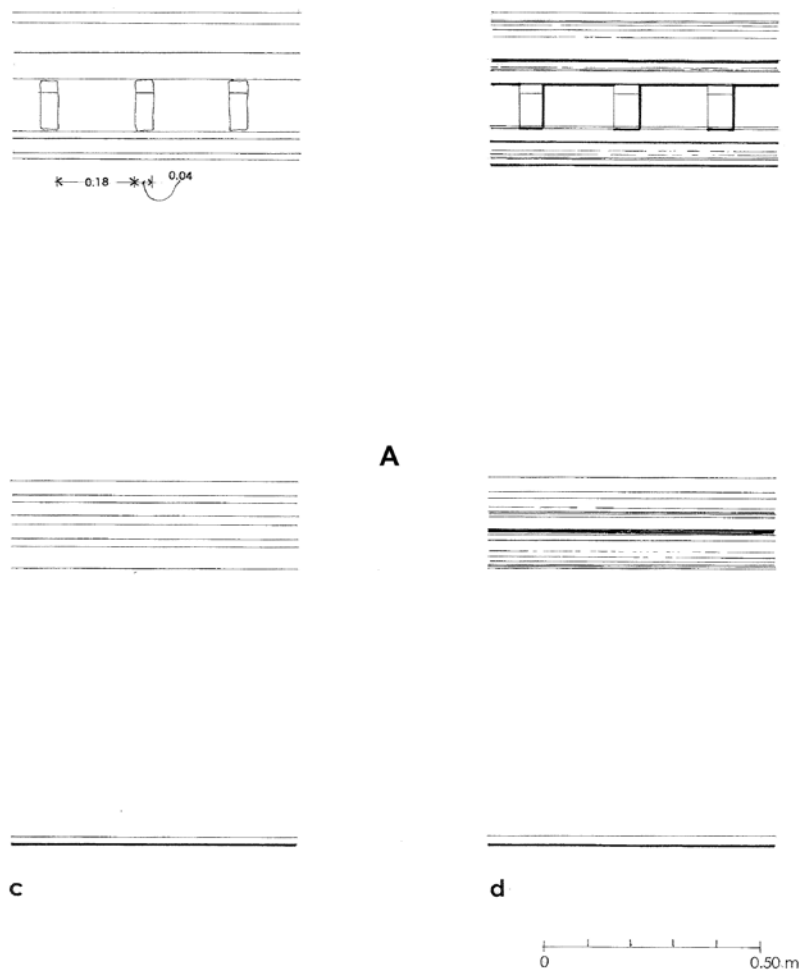

Fig. 451. Abbasahchina, vihara F Podium (A). *c.* elevation, without plaster, showing the measures of the brackets. *d-e.* reconstructed elevation, with plaster. (Sabelli 1993; Martore 2003).

B. Viharas

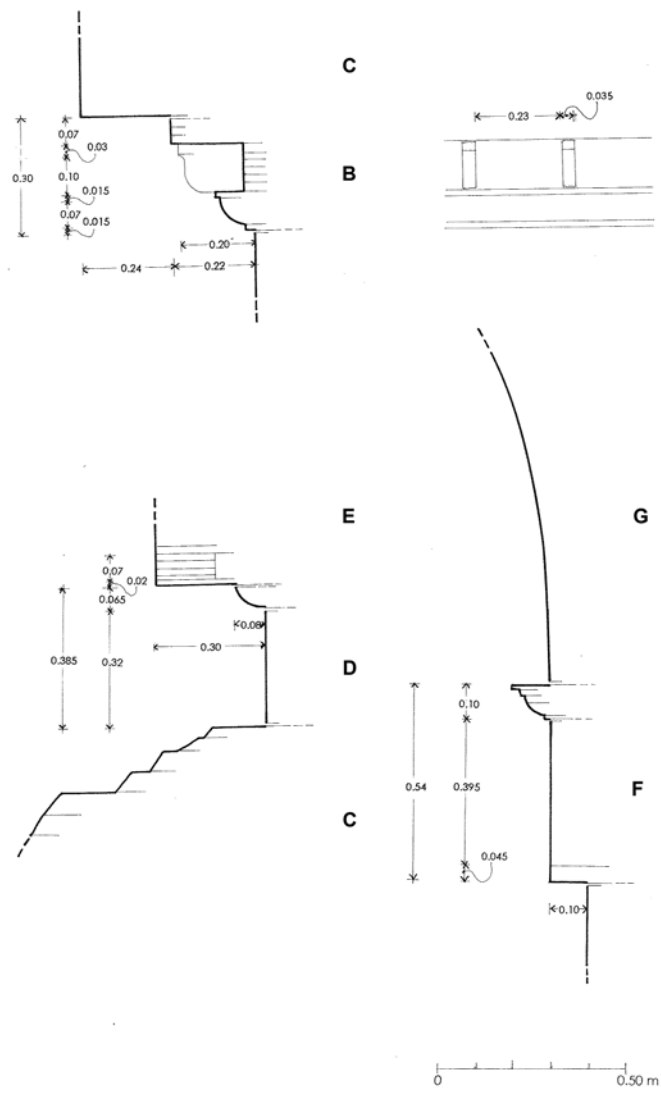

Fig. 452. Abbasahebchina, vihara F Detail of B, C, D, E, F, G mouldings showing the measures. (Sabelli 1993; Martore 2003).

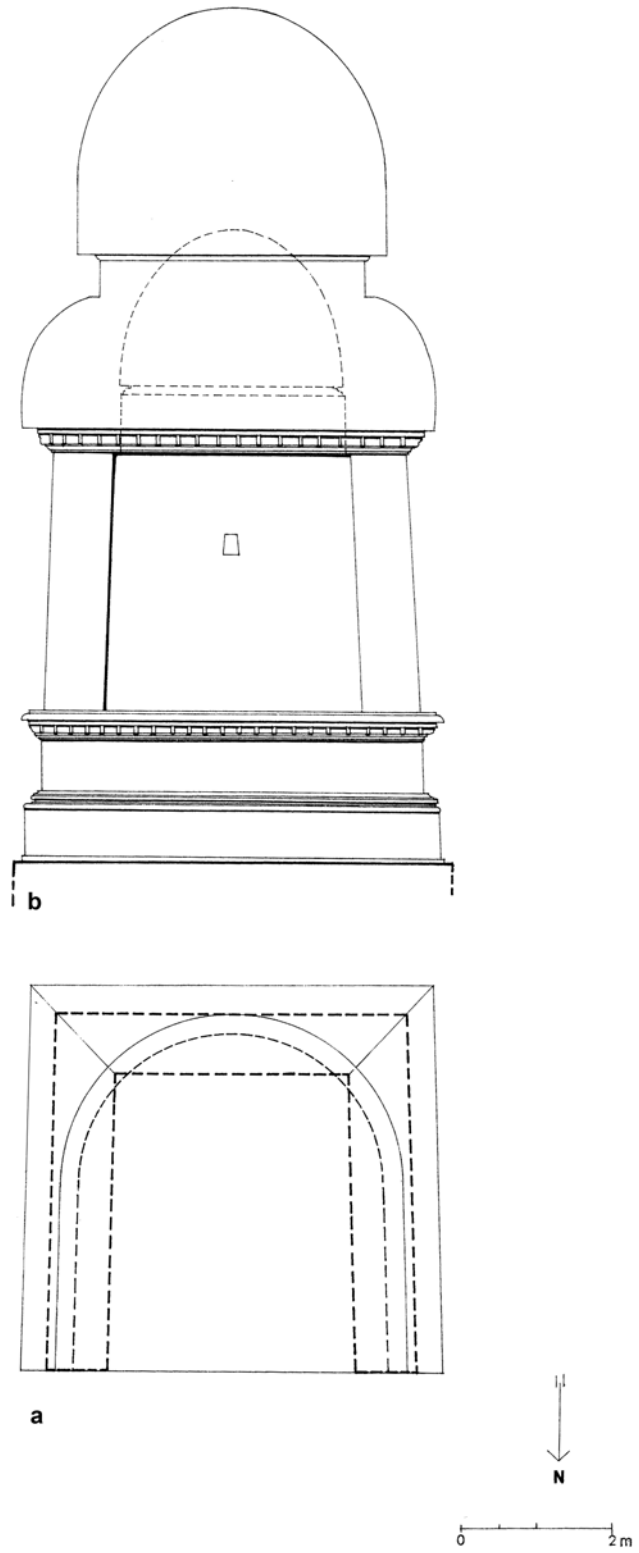

Fig. 453. Abbasahbchina, vihara F *a-b*. reconstructed plan and elevation (frontal side, N).
(Sabelli 1993; Martore 2003).

B. Viharas

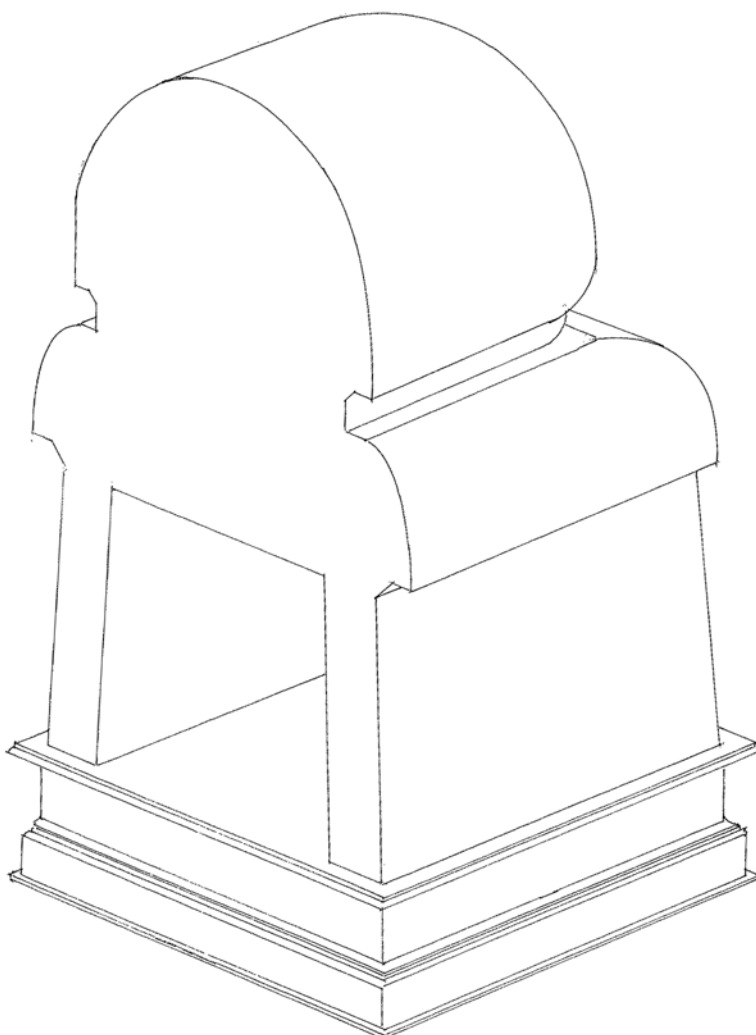

Fig. 454. Abbasahebchina, vihara F. Axonometric view. Scale 1:10. (Martore 2003).

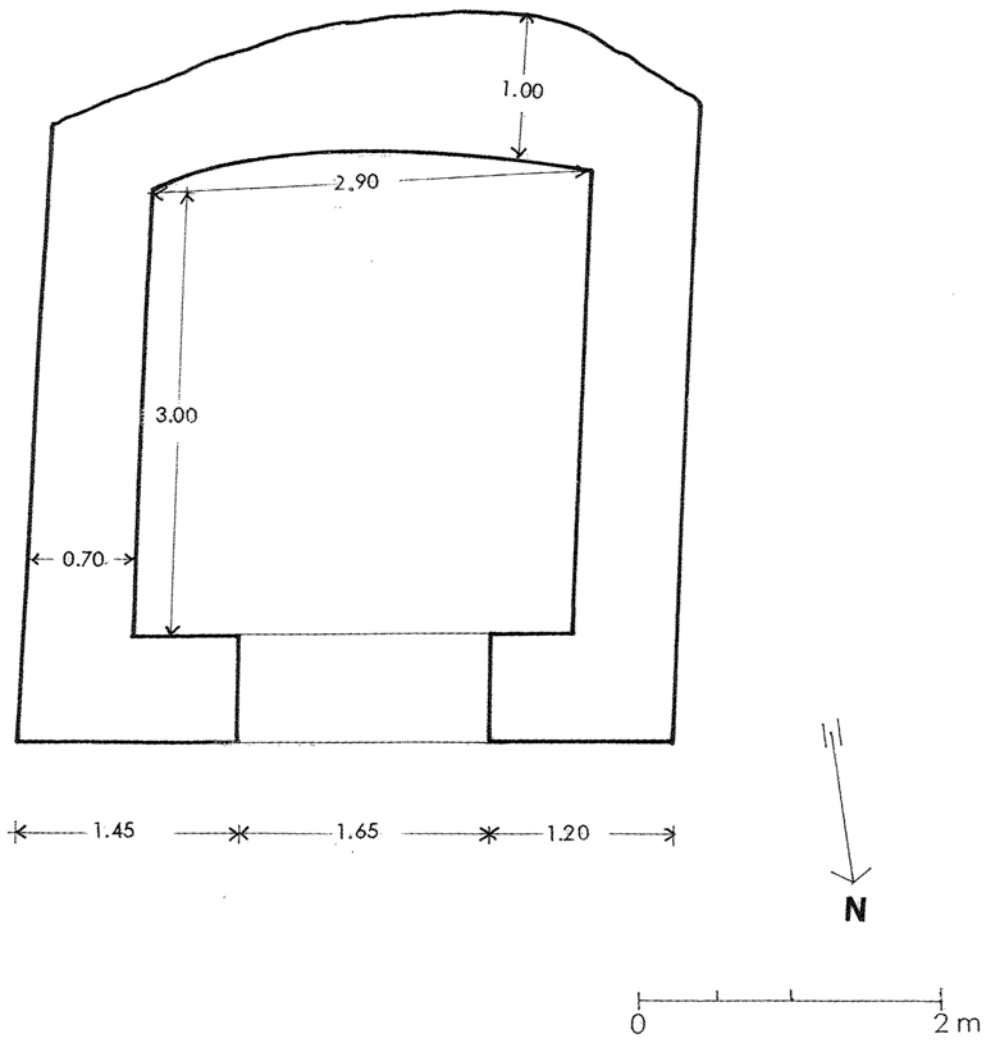

Fig. 455. Abbasahbchina, small vihara B1.2. Plan showing the measures.
(Caroli 1957; Martore 2003).

B2. Vihara of Gumbat

(Figs. 456-498)

The Site

Zone of Barikot.

Position: Lat. 34° 37' N; Long. 72° 10' E; SPM 43 B/2.

Following the Kandak valley upstream, about 6.5 km from Barikot, and 2.2 km from Kanjar Kote, on the right bank, after a steep climb one reaches the sacred area dominated by the vihara; the latter is visible from a distance and is quite well conserved.

Bibliography and Documentation

Stein 1929: 31-32, figs. 11-12 ⁽¹⁾; 1930: 12-14, figs. 6-7, pl. 4 lower left (figs. 6 and 7 correspond to figs. 11 and 12 of Stein 1929) ⁽²⁾.

⁽¹⁾ 'An architecturally interesting structure known appropriately as Gumbat, the "dome" (figs. 11, 12) which rises on the hill-side near a spring some six miles from Bīr-koṭ, had fortunately fared better. It consists of a cella nearly twelve feet square within, surrounded on all sides by a narrow passage intended for the circumambulation of sacred images that Buddhist worship, like Hindu cult to this day, prescribes. Small windows piercing the massive walls of both cella and passage gave light to the interior. This probably once contained a colossal standing image of the Buddha; for it would be difficult otherwise to account for the great height, close on fifty feet, of the dome surmounting the cella. Its interior, filled to a considerable height with refuse accumulations, was occupied by a Gujar family from the neighbouring hamlet of Bālo, while the passage was utilized to shelter their buffaloes. On terraces close by I was able to trace the position of several small Stūpas, now completely demolished, and to pick up much-decayed little fragments from relievos, which modern searchers for 'idols' had thrown aside in the course of their destructive operations'.

⁽²⁾ 'Ruined shrine at Gumbat — Better preserved and more interesting architecturally was the ruined structure appropriately known as *Gumbat*. It was visible from a considerable distance and was reached after a steep ascent over rocky slopes above the Gujar hamlet of Balōt-kile. This lies up the western side of the valley and about four miles from Bīr-koṭ. The domed structure proved of unusual shape, comprising a high cella surrounded by a narrow vaulted passage which obviously was intended for the performance of *pradakṣiṇā*. As seen in fig. 6 the side facing east and containing the entrance had completely broken down. But the walls of the cella had remained practically intact and so also the outer walls of the passage on the west and over most of the other two sides (fig. 7). This comparatively good preservation of the shrine was obviously due to the solidity of the masonry. This consists mainly of large slabs, up to 4 feet in length and about 6 inches thick, the

Barger & Wright 1941: 16-17 ⁽³⁾, 57-59, pls. III.1-4, V.1, VII.1, VIII.3 (sculptures).

Tucci 1958: does not mention it.

Faccenna 1959: inspection with V. Caroli; description, lacking graphic and photographic documentation.

Vallazza 1961: photographic documentation.

Gui and Cimmino 1964: graphic survey of building and surrounding area.

Photos taken at different times by Italian Archaeological Mission members: Faccenna; Bonardi; Taddei; Scerrato.

Franz 1981: 452-43, figs. 5-8; 1984: 131, figs. 6-7.

Vidale 2000: photographic documentation and description.

Olivieri and Vidale 2004.

whole carefully set in Gandhāra fashion.

‘As seen in the sketch plan and section, pl. 4, the rectangular cella measures 11 feet 3 inches by 12 feet within walls 3 feet thick. They are pierced on three sides by narrow windows which correspond to slightly wider ones admitting light to the passage. The passage is 3 feet 3 inches wide and its vaulted roof springs at a height of approximately 17 feet above the ground. But the exact level of the original flooring could not be determined as the interior both of passage and cella is filled to a considerable height with refuse accumulations. I found the cella occupied by a Gujar family while part of the passage was used to shelter their buffaloes. A heavy curving roof springs from a boldly projecting cornice and covers the passage. Above this there rises the high bulb-shaped dome having a diameter corresponding to the width of the cella. It was not possible to ascend to the top of the dome and to determine its exact height. But judging from such measurements as could be taken on the exterior of the structure its total height above the probable level of the original ground could not be less than 43 feet. A hole was broken through the top of the dome. The great elevation of the latter suggests that the cella might have once contained the colossal standing figure of a Buddha or Bodhisattva, likely to have been modelled in stucco. But only a complete clearing could throw light on the true character of the shrine.

‘A terrace to the south of the structure bears the remains of massive walls and what seem to have been the foundations of small Stūpas. These all had been recently dug into by men searching for sculptures on behalf of the same employer as at the ruined shrine of Nal village. Small broken pieces of reliefs could be picked up in numbers from rough enclosures erected around by Gujars. [...]

‘A completely dug up mound near the north-eastern corner of the shrine probably marks the position of a Stūpa of moderate size. On the steep slope below the western side of the ruin there lay a circular stone slab, 6 1/2 feet in diameter, which obviously had served as a chhatra. It was difficult to ascertain over which structure this large stone may have originally been placed. The dome over the cella could scarcely have supported a series of such heavy stone umbrellas. It remains to be noted that close to the SSW. of the ruined ‘Gumbat’ there is found a small spring which probably accounts for ‘the position of this Buddhist sanctuary’.

⁽³⁾ ‘*Excavations at Gumbat* — A mile and a half south of Kanjar Kote on the side of the valley are a group of mounds, representing the remains of the stūpas, and a shrine with a high dome, which probably gives the site its name of Gumbat. For a description of the shrine, a bare shell of Gandhāra masonry now inhabited by a Gujar family, reference may again be made to Sir Aurel Stein’s report. The stūpas on either side of the shrine were much more decayed even than the stūpa at Kanjar Kote, and partly overgrown with scrub. But here, as elsewhere, the surface remains were no trustworthy indication of what lay below. The sculptured remains dug up round one stūpa at Gumbat were far more numerous, and in general better preserved, than those discovered in the stūpa court at Kanjar Kote.

‘It was impossible to clear any of the stūpas on the southern side of the shrine as they were surrounded by fields under cultivation. Accordingly, operations were confined to the stūpa mound to the north of the shrine. Its top had long since been trodden down, and was used by the Gujars as a milking place for their cattle. Lower down, patches of wall made it possible to trace the line of the stūpa base which was 31’ square. It was found to be surrounded by small stūpas, standing on a pavement which was reached at 5’ below the surface.

A number of stone fragments were recovered from the debris round the large stūpa and between the small ones’.

Spagnesi 2004: photographic documentation.

Martore 2004: graphic updating and inclusion of measures and details.

Faccenna 2006: 189-94, figs. 10-11.

Spagnesi 2006: 171, figs. 25-26.

The site has been included in the Archaeological Map of the Swat Valley (Olivieri & Vidale 2006: 108, fig. 60).

The Vihara

Stein's description, to which Barger and Wright refer, was supplemented by Faccenna's notes (1959) and the graphic documentation made by Gui and Cimmino (1964). The main source used for the description of the monument with interesting results is this abundant, thorough and complete graphic documentation carried out by the two authors. In some of this graphic material F. Martore intervened in the graphic layout, the inclusion of measures and the addition of details.

The vihara has a podium with stairway to the E, cell with corridor around the perimeter, double roof covering, the lower one with four curved folds and, separated from the latter by a low cylindrical storey, the upper one in the form of a dome. At the base it measures (N, S) 8.85 x 8.90 (W, E); max. h. 15.45.

After the collapse of the front part with the wall and opening giving access to the vihara and with the corridor, of which the vault springers have been conserved, the vihara displays the entrance to the cell and the beginning of the two side corridors; the lower part with the podium and the stairway has been buried and is no longer visible. The door opening may be reconstructed on the basis of the shape of that of the cell.

Cell

The entrance tapers towards the top and has slightly inwardly splayed door jambs. The room has a square plan (3.50 x 3.60) with high walls (h. 6.37); it is covered with an ogival dome vault that springs from a row of slabs protruding from the wall and in the corners it reaches the level of the cornice of the intermediate cylindrical storey and penetrates the dome shaped structure (h. 3.15).

A small circular shaped room has been constructed on top which also has an ogival dome (h. 2.10).

As the terminal part of the dome-shaped structures is missing it is impossible to determine how this and the inner cavity were closed and whether there was any connection between them. It is also impossible, owing to a gap in the masonry (thickn. 0.15) to ascertain the presence of a connection through an aperture between the two superimposed domes.

Corridor around the Perimeter

The corridor (h. 3.05, width 1.00), with slightly tapering walls, is covered with an ogival vault corresponding to the covering with curved folds. The vault springs from a row of slightly protruding slabs; starting flush with the latter it first rises vertically and then begins to curve with obliquely shaped slabs (max.h. 0.75). Join elements occur where the corridor arms meet.

External Mouldings of the Various Storeys of the Construction

Podium: it has a base, the shape of which has been simplified graphically and incompletely owing to the difficulty of surveying it. The cornice may be considered of the ovolo type with two or three slabs whose profile has not been conserved, perhaps with a protruding reverse ovolo.

Cell: this springs directly from the podium cornice and ends in a corbelled cornice consisting of an ovolo between two fillets, a row of brackets and a wide fillet.

Lower roof covering with curved folds: on the cornice of the cell the covering juts out.

Intermediate body: base missing, with a cornice that repeats the one below.

Upper dome-like covering: first it rises straight and then makes a long gentle curve and comes to an abrupt end at the top, taking on a imposing lofty appearance.

Lighting

The daytime and nighttime lighting system is particularly interesting; it is based on the arrangement of the windows and on the location of the lamp niches.

Two windows per side open from the outside on to the corridor, except on the front where there is the entrance opening. On all sides one window corresponds to the principal axes while the other immediately beside it corresponds to the head of each arm of the corridor. In the missing central anterior part, in addition to the central one on the N side it is necessary to hypothesize another window corresponding to the W corridor; there must have been a further one on the W side to the left of the entrance.

This precise system of alternating apertures starting from the axes of the construction ensures uniform illumination on all four sides. The aperture of the single window, limited below and above by a schist slab, is trapezoidal in shape with an equal symmetrical splay at the sides, larger towards the interior for the obvious purpose of light diffusion.

There are other openings in the intermediate cylindrical storey between the two coverings. They are always situated on the principal axes; they have trapezoidal

shape with a wall splay opening towards the interior, symmetrically in line with the N and S walls, with the N wall more inclined.

For the purpose of nighttime lighting lamps were placed in small niches made in the wall using three slabs arranged in a triangle, set in twos at the sides of the entrance of the cell windows, of the corridor windows on both the outer side, which is assumed as it was not possible to make a complete examination owing to the various encumbrances, and on internal side corresponding to those of the cell.

Stairway

A short sondage dug during the survey revealed the presence on the W side of a stairway (width 2.00, leng. 4.00) connected to the vihara podium by a projection (width 3.20, leng. 1.45), around which the cornice of the podium itself turned. The steps, as a function of the height of the podium and their known mean measures may be calculated as being 15 or 16 in number, the tread of the top step arriving below the coping of the projection with the ramp having an inclination of 34°. The presence of the stairway gives the monument a different, more imposing, appearance.

As may be seen in figures 6 and in the section in Stein's (1930) pl. 4, he uncovered to a large extent, or else they were at least partially visible, two sides of the podium to the S and E without assuming the existence of a stairway.

Construction Technique

Blocks of good height and length were used on the vertical walls; they are laid in regular staggered rows, separated by rows of small schist slabs and linked together by small superimposed slabs. When the distance between them is greater, a small square block is inserted in between. The blocks become smaller in size in the curved walls and in the roof coverings. Extensive traces of plaster remain on the dome walls and it may be assumed that all the surfaces were plastered.

Conservation and Restoration

Comparing Stein's photos (1930) with the present situation (2004) reveals that the monument has maintained the same appearance, which is quite incredible when compared with the conditions found in the other buildings. The front part with the corresponding corridor had already collapsed in the past; there are vertical cracks in the E and W sections of the dome always running from the latter side to half way across the width, starting from below, the result of structural weakening perhaps due to seismic stress.

Its original appearance is rendered in the perspective view (Cimino 1964); it must be imagined with its plaster coating, probably heightened by colour.

The monument, although still displaying a substantial solidity, is in need of safeguarding, maintenance and consolidation measures (rather than restoration) in order to conserve one of the most complete and significant buildings of its kind not only in Swat but in the entire Gandharan area.

The Sacred Area

The vihara stood on a large terrace supported on the N side by a retaining wall with four sloping buttresses.

Beside the vihara, viewed by Gui and Cimino (1964) also after clearing and short sondages as reported and numbered in their ground plan, there is a square stupa to the S and another smaller one to the E and other smaller ones nearby.

Faccenna (1959) notes on the E side a large disk with holes on the perimeter and a reverse ovolo edge, which was mentioned by Stein (diam. 6½ ft.).

An interesting detail shown in a sketch (Gui 1964) shows the corner of the cell with the dome springer. In addition to the stone slabs (?) a footnote mentions the use of a wooden beam. This detail is not mentioned in Faccenna's later notes (1969), nor was it possible to observe it subsequently.

For several mentions and comparisons regarding this type of vihara with central cella and perimeter corridor see the Conclusions.

B. Viharas



Fig. 456. Vihara of Gumbat. View, S and E sides. (After Stein 1930: fig. 6 [=1929: fig. 12]).

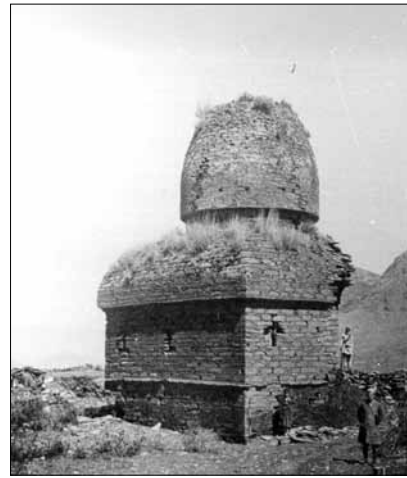

Fig. 457. Vihara of Gumbat. View, S and W sides. (After Stein 1930: fig. 7 [=1929: fig. 11]).

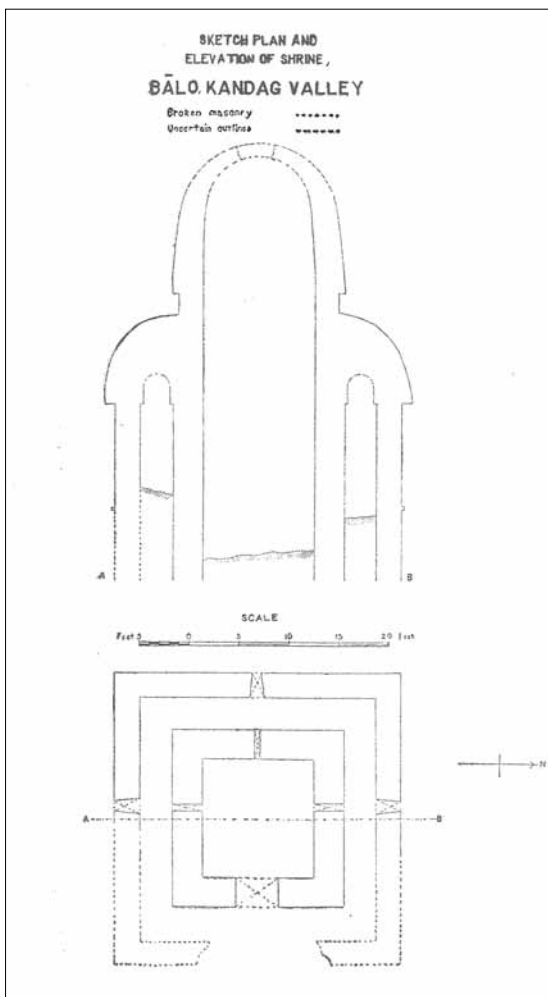

Fig. 458. Vihara of Gumbat. Sketch plan and N-S cross section. (After Stein 1930: pl. 4 on bottom left).



Fig. 459. Vihara of Gumbat. View from E. (Taddei 1959; Neg. CS).

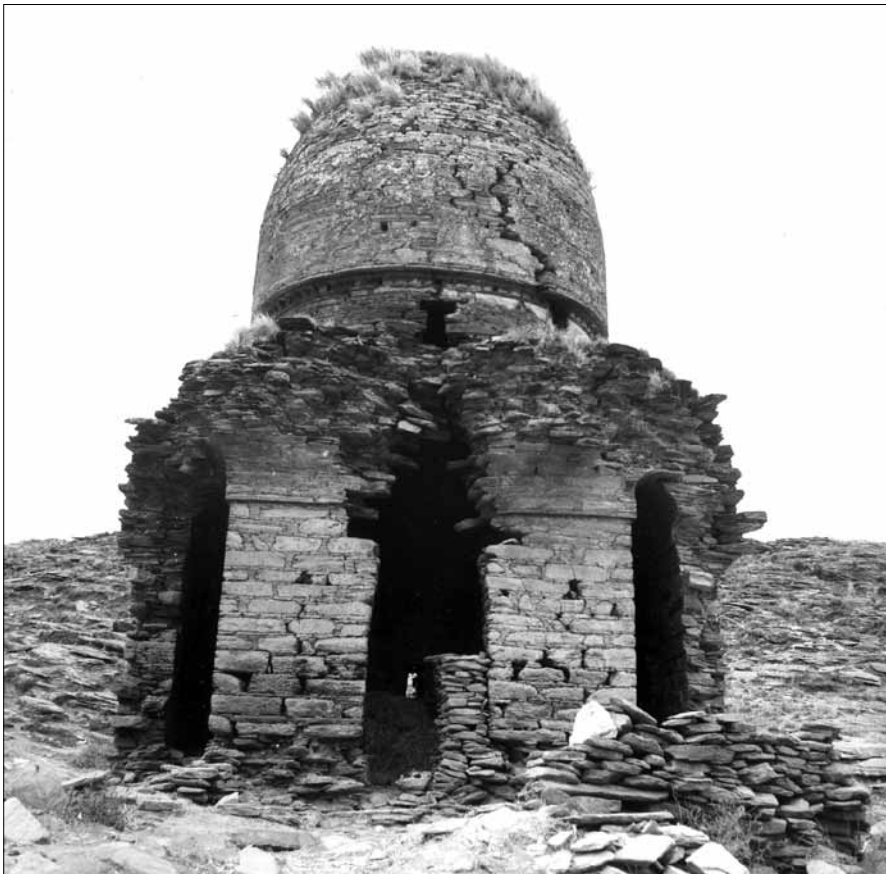

Fig. 460.
Vihara of
Gumbat. E
side. (Bonardi
Tucci 1952).

B. Viharas



Fig. 461. Vihara di Gumbat. S and E sides. (Taddei 1959; Neg. 8/19).



Fig. 462. Vihara of Gumbat. Cell, S and E sides. (Taddei 1959; Neg. CS).



**Fig. 463. Vihara
of Gumbat. S side.
(Taddei 1959; Neg.
CS).**



**Fig. 464. Vihara
of Gumbat. S side,
detail. (Taddei 1959;
Neg. CS).**



Fig. 465. Vihara of Gumbat. S side; cornice of the lower roof covering. (Taddei 1959; Neg. CS).

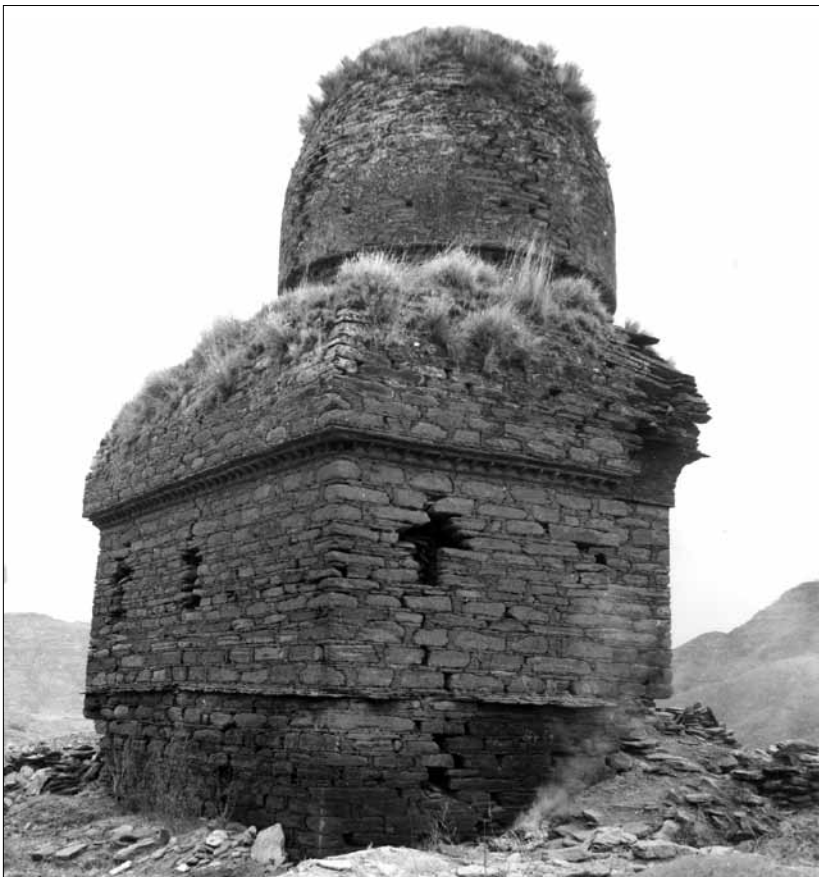

Fig. 466. Vihara of Gumbat. S and W sides. (Bonardi Tucci 1959; Neg. CS).

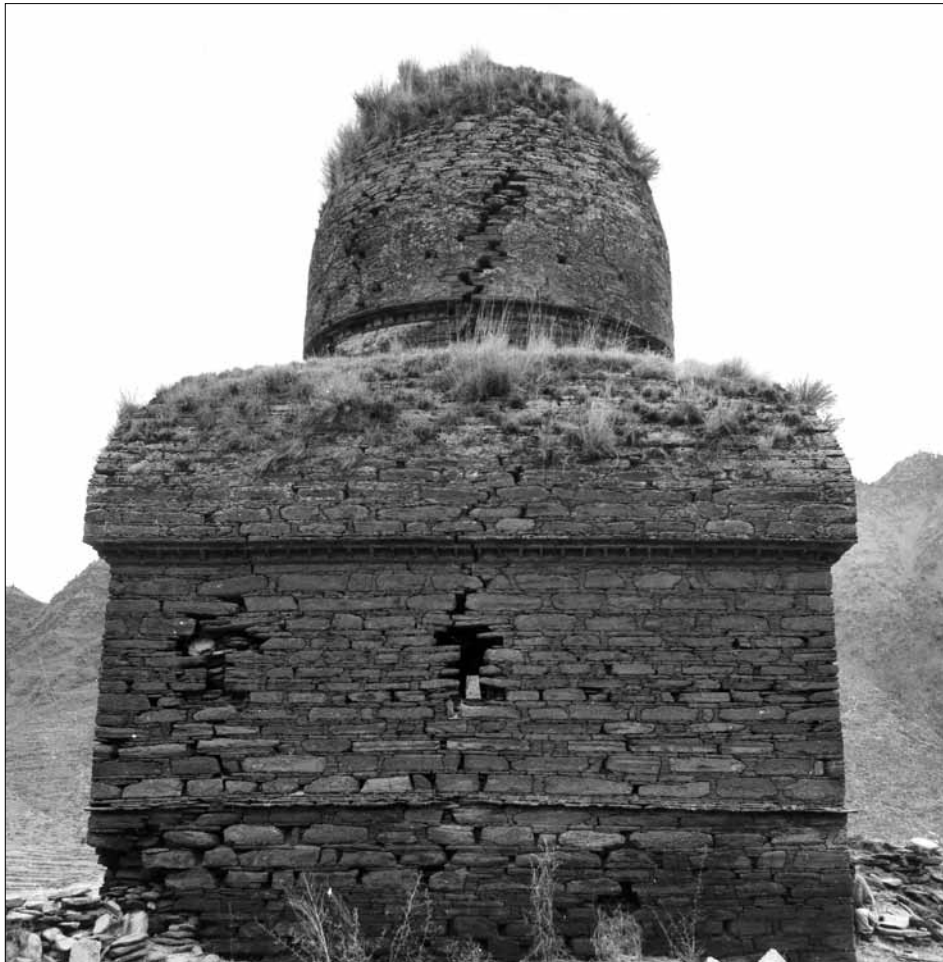

Fig. 467. Vihara of Gumbat. W side. What to be noted is the aperture on the transition storey between the two roof coverings (lower and dome) and the detaching of the dome. (Bonardi Tucci 1959; Neg. CS).



Fig. 468. Vihara of Gumbat. E side. (Spagnesi 2004).



Fig. 469.
Vihara of
Gumbat. W
side; detail
showing an
aperture and
a cornice.
(Bonardi Tucci
1959; Neg. CS).



Fig. 470. Vihara of Gumbat. S side; detail of the decoration of the podium and of the construction technique. (Taddei 1959; Neg. CS).



Fig. 471. Vihara of Gumbat. SE side; cornice of the lower roof covering. (Taddei 1959; Neg. CS).



Fig. 472. Vihara of Gumbat. E side; transition storey with the window opening and upper dome. (Taddei 1959; Neg. CS).

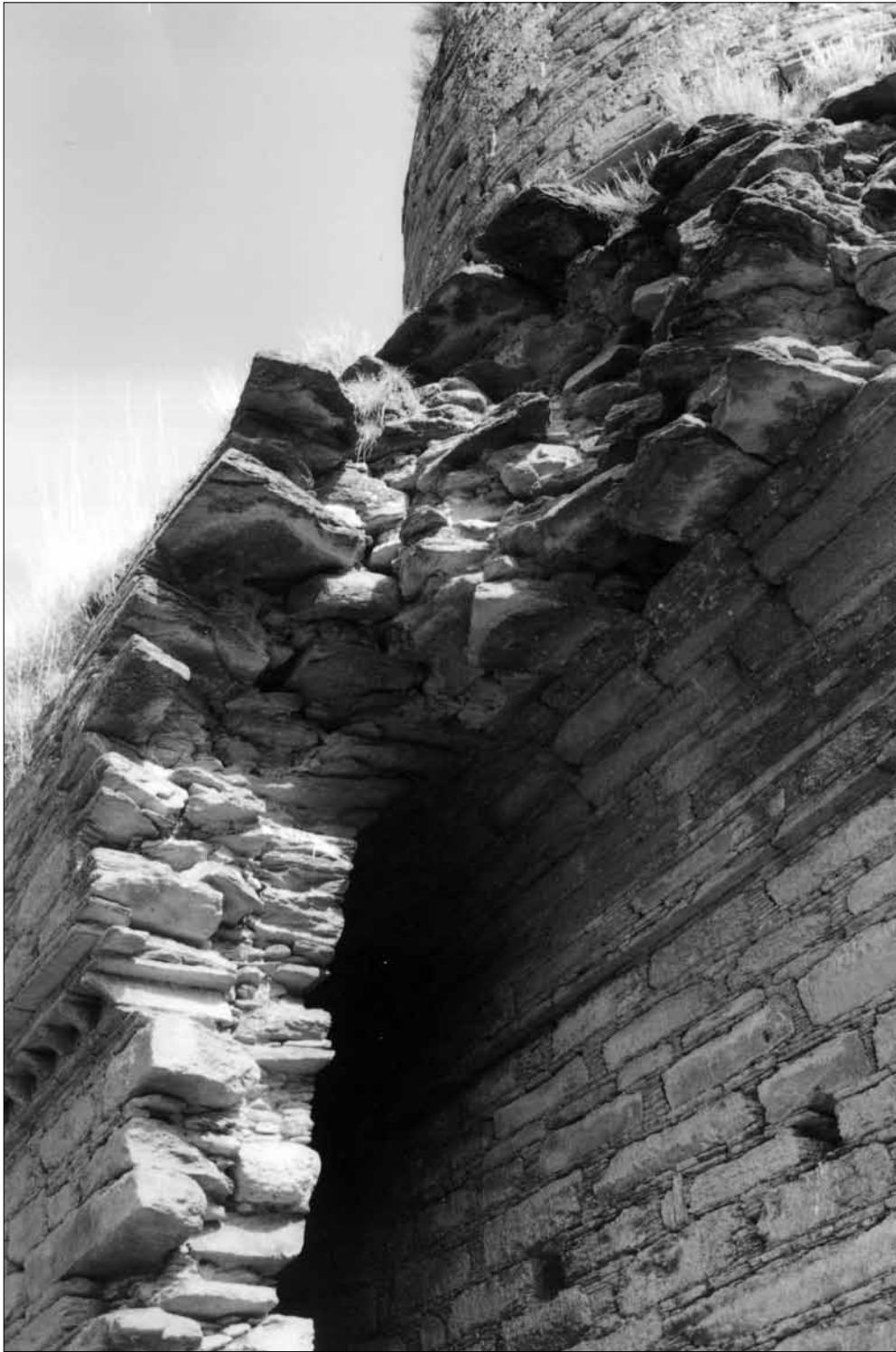

Fig. 473. Vihara of Gumbat. E side; S corridor, initial stretch of the vault springer. (Spagnesi 2004).



Fig. 474. Vihara of Gumbat. S corridor, vault. (Taddei 1959; Neg. CS).



Fig. 475. Vihara of Gumbat. S corridor, vault at the joint with the W corridor. (Taddei 1959; Neg. CS).

B. Viharas



Fig. 476. Vihara of Gumbat. Cell, inside, corner with dome springer. (Taddei 1959; Neg. CS).



Fig. 477. Vihara of Gumbat. S side; aperture on outer wall of the window. (Taddei 1959; Neg. CS).



Fig. 478. Vihara of Gumbat. S side; aperture on inner wall of the same window shown in fig. 477. (Taddei 1959; Neg. 8/42).



Fig. 479. Vihara of Gumbat. S corridor, N wall; aperture used for daylight and, above, triangular niche for oil-lamp. (Taddei 1959; Neg. CS).

B. Viharas

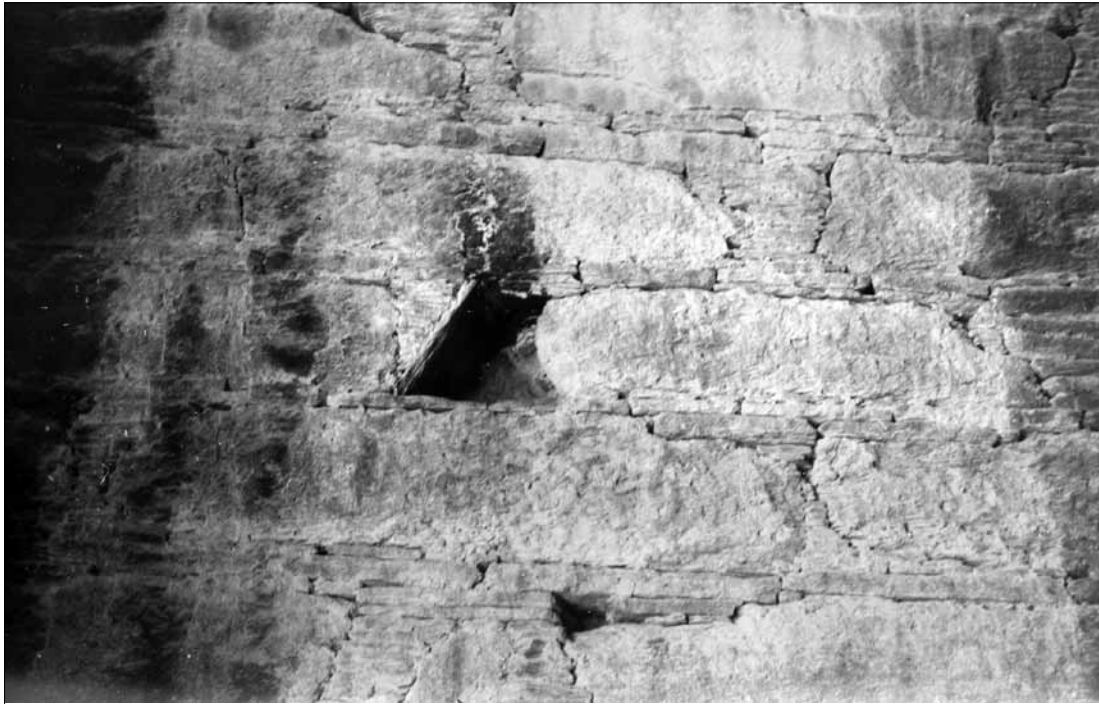

Fig. 480. Vihara of Gumbat. Corridor; triangular niche for oil-lamp. (Taddei 1959; Neg. CS).

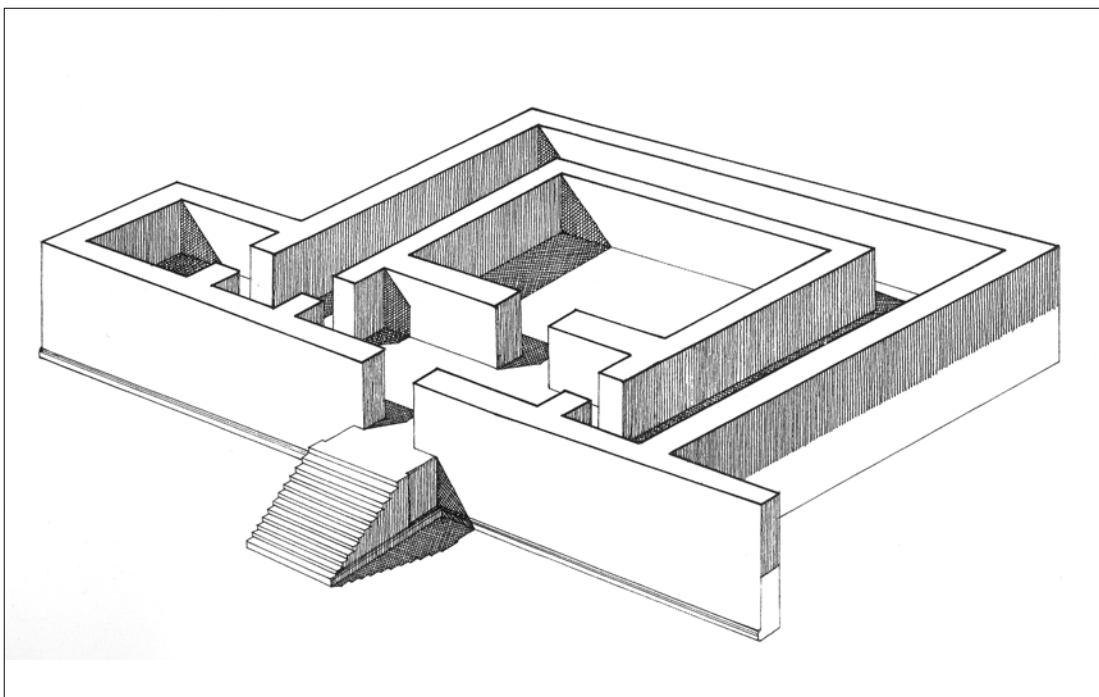

Fig. 481. Butkara I, Great Vihara. (After Faccenna 1980-1981: fig. 56; 2001: 168, fig. 48).

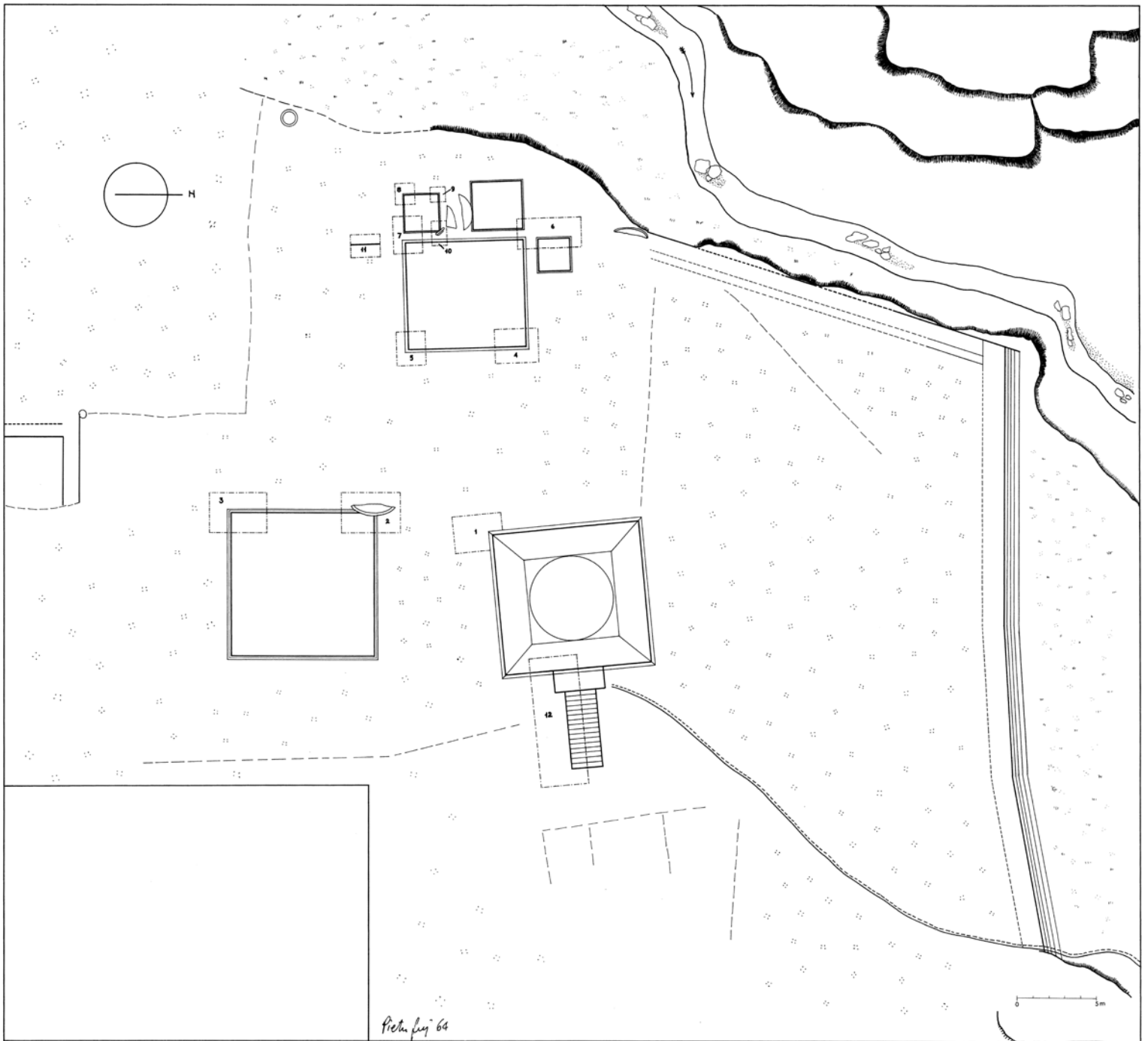

Fig. 482. General planimetry of the Sacred area in 1964 (Gui 1964).

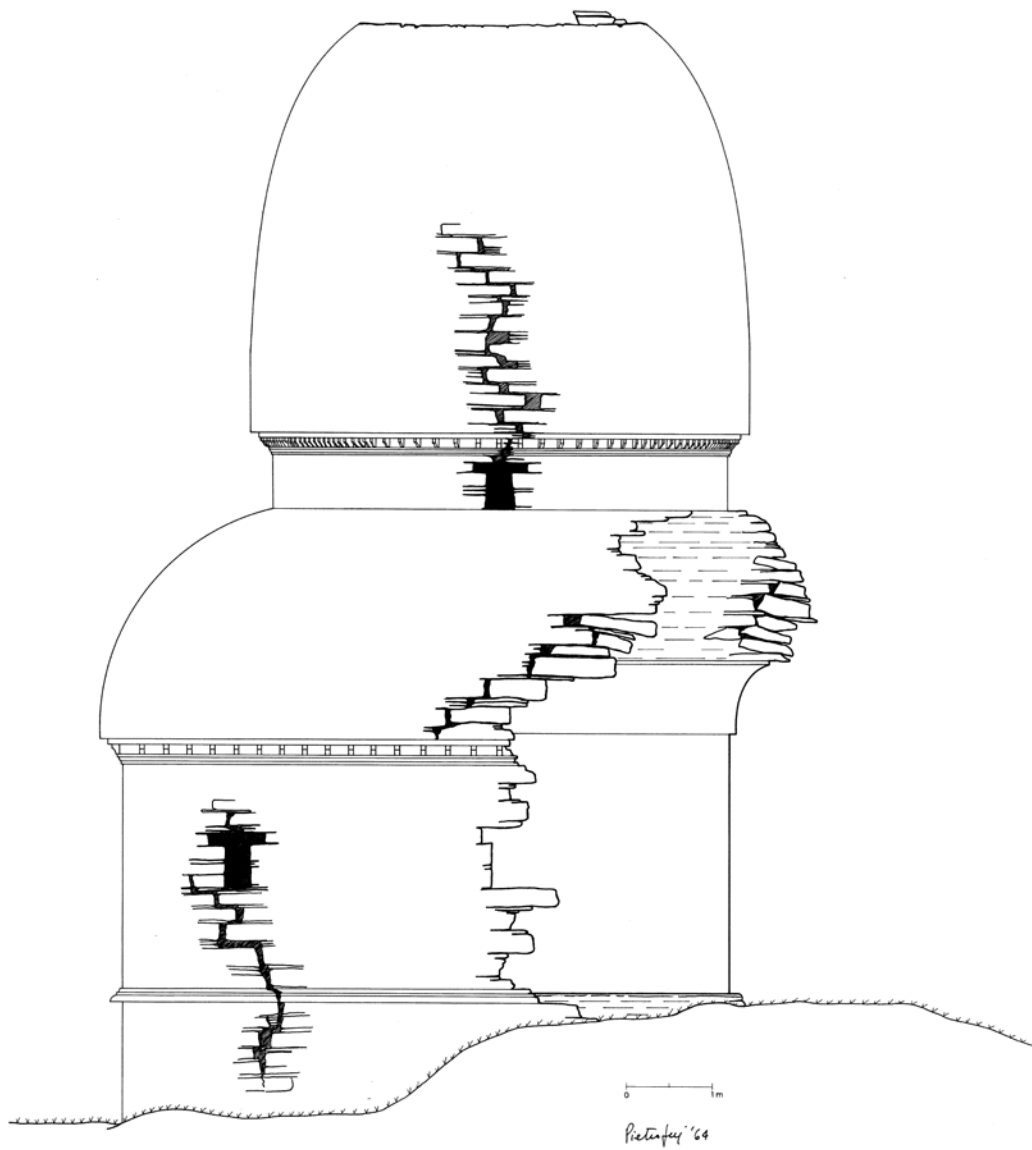

Fig. 483. Vihara of Gumbat. S elevation. (Gui 1964).

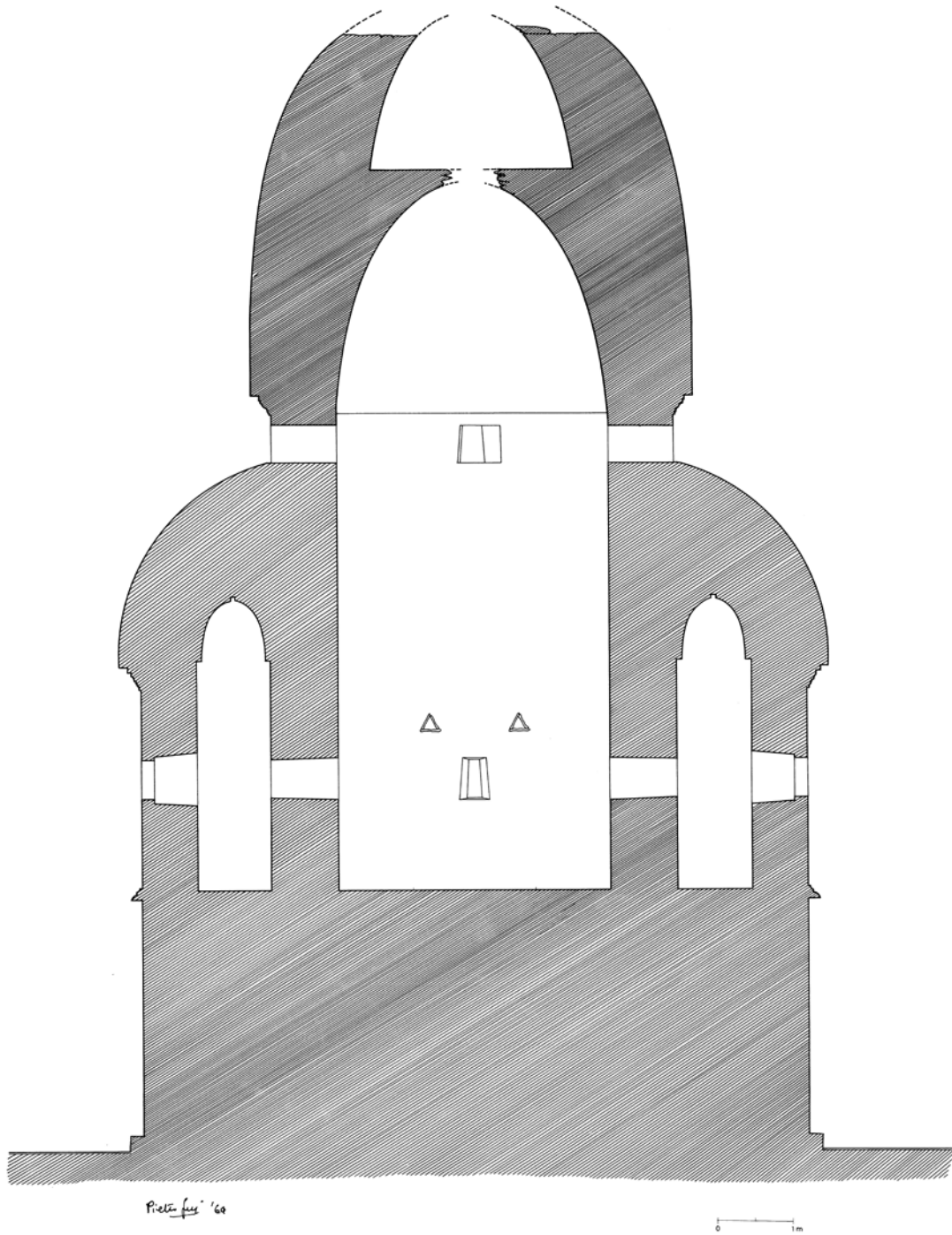

Fig. 484. Vihara of Gumbat. N-S cross section. (Gui 1964).

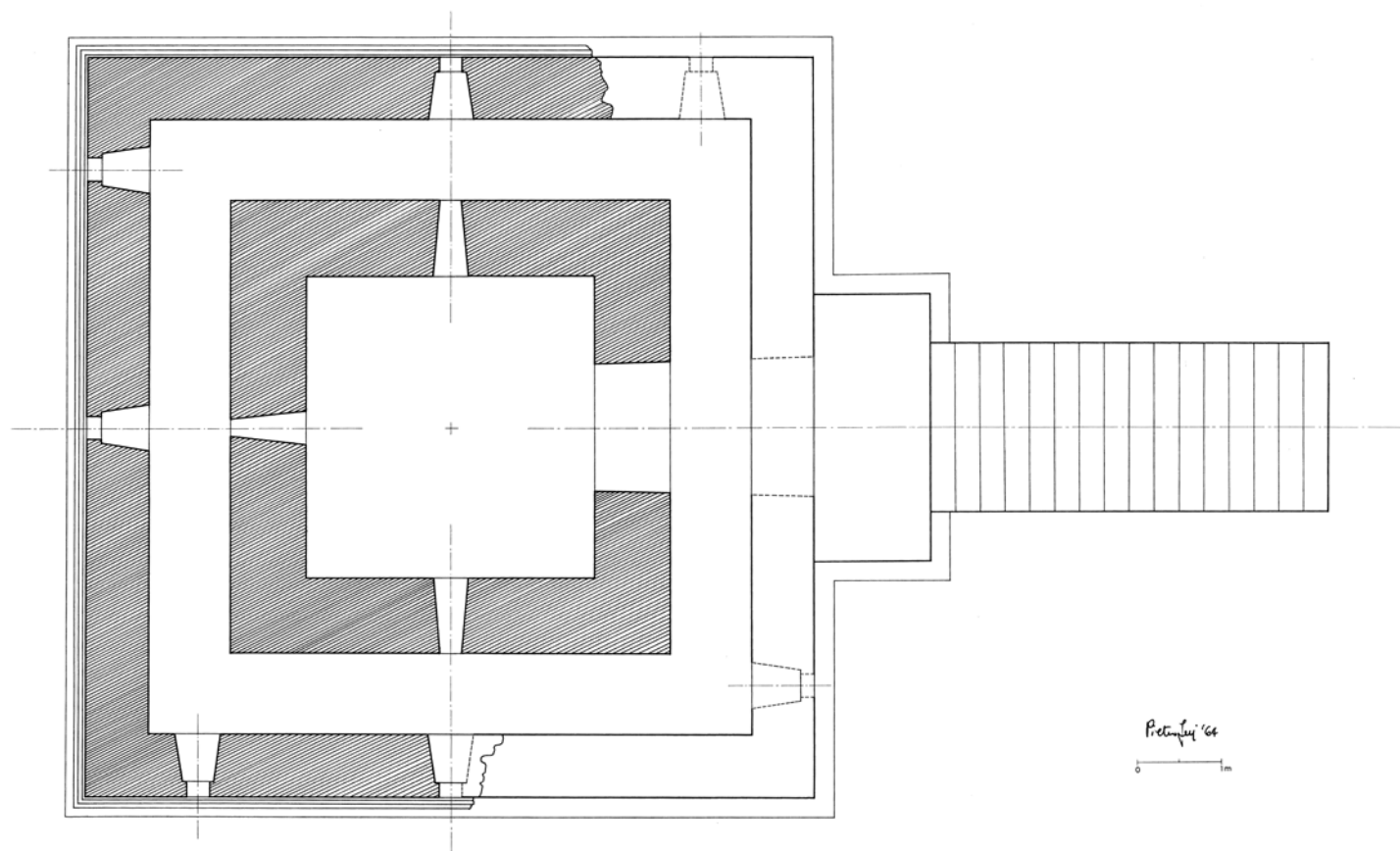

Fig. 485. Vihara of Gumbat. Plan showing a horizontal cross section at the level of the first row of the windows, reconstruction showing the podium and the flight of stairs from E. (Gui 1964).

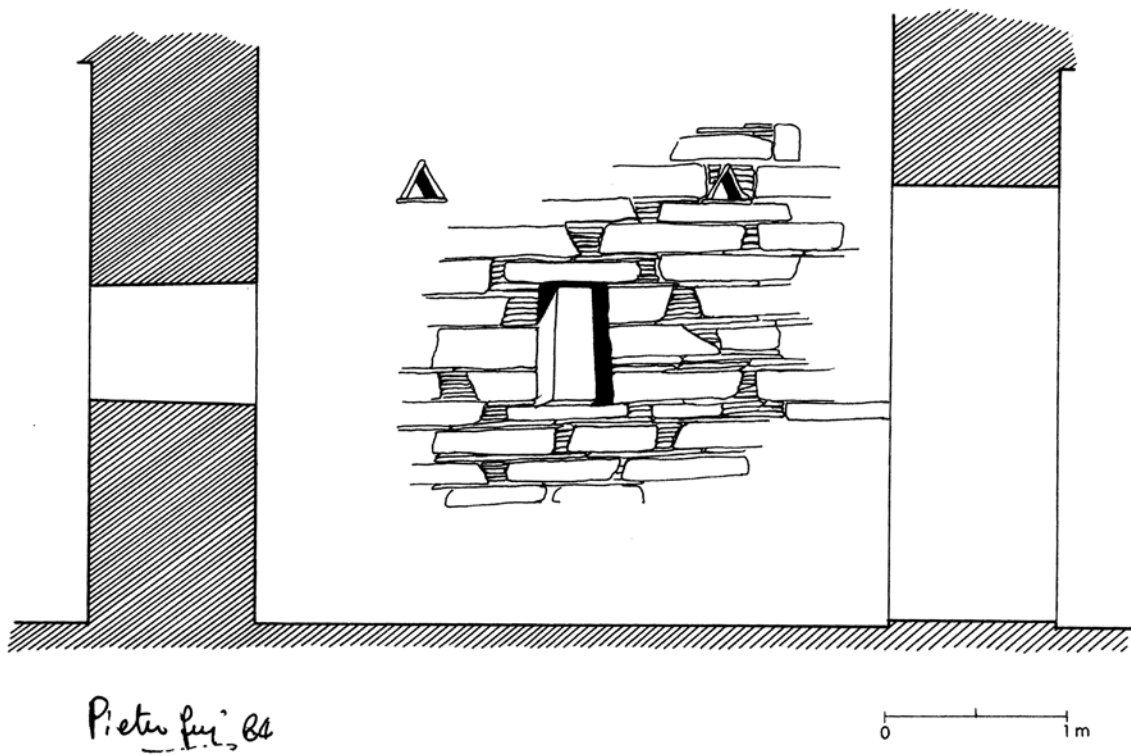

Fig. 486. Vihara of Gumbat. Drawing N wall (on the right of the entrance) of the cell.
(Gui 1964).

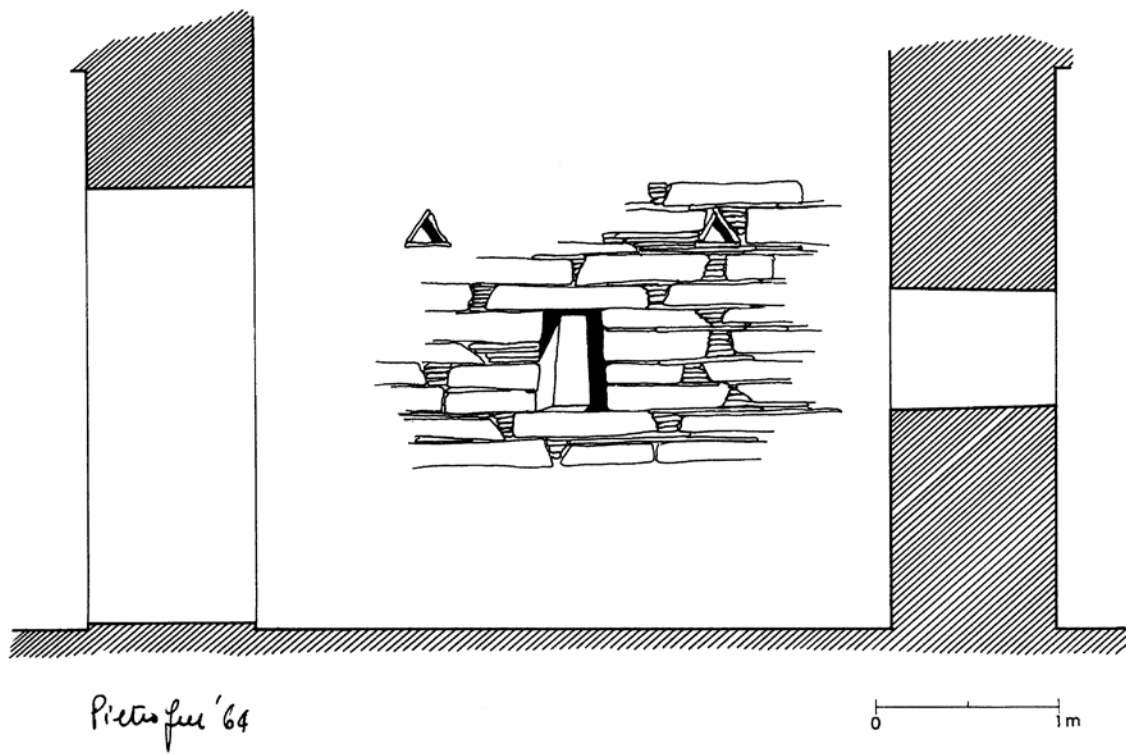
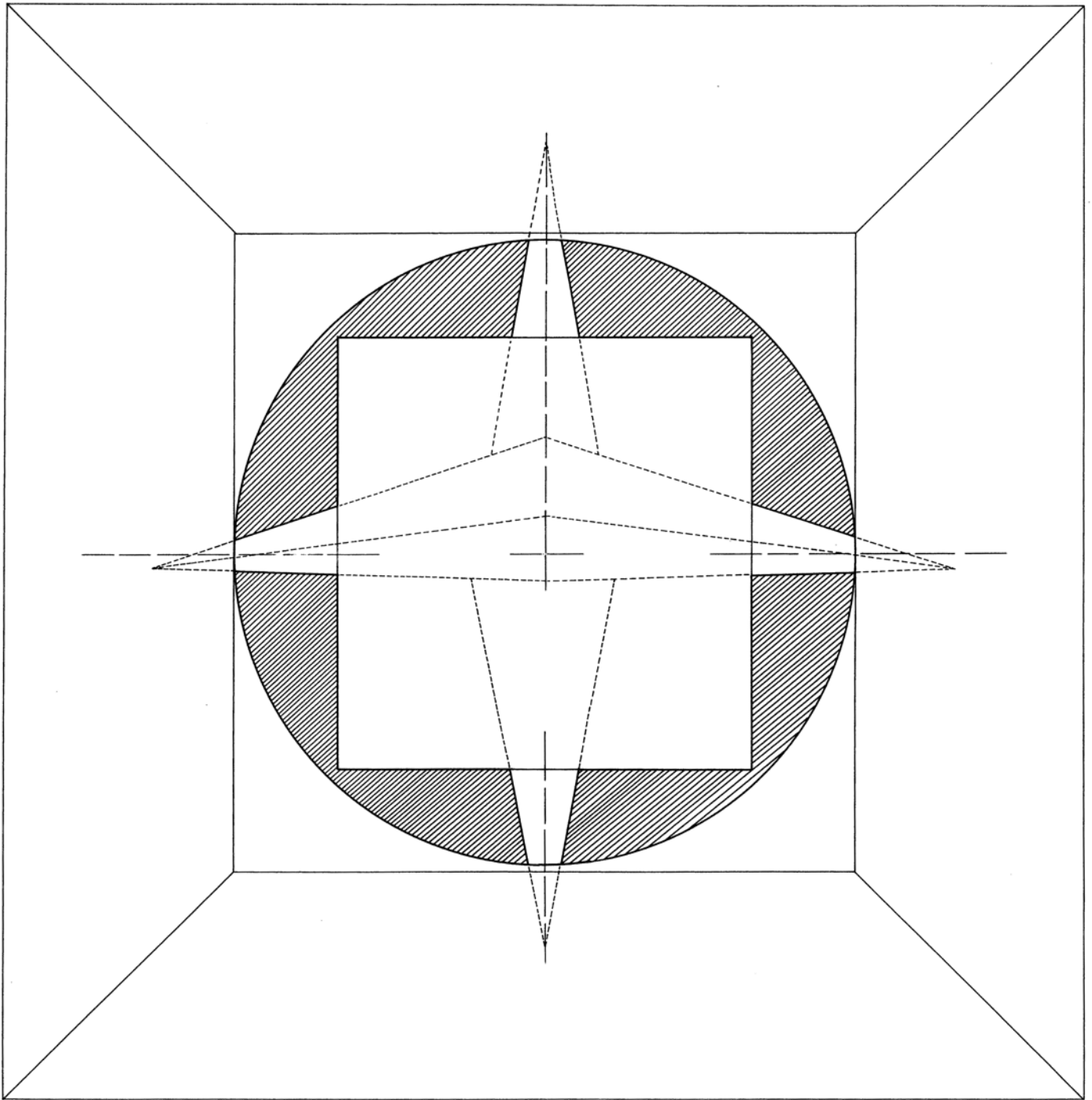

Fig. 487. Vihara of Gumbat. Drawing S wall (on the left of the entrance) of the cell. (Gui 1964).



Piero Gui '64

0 ——— 1m

Fig. 488. Vihara of Gumbat. Plan showing a horizontal cross section at the level of the second row of the windows. (Gui 1964).

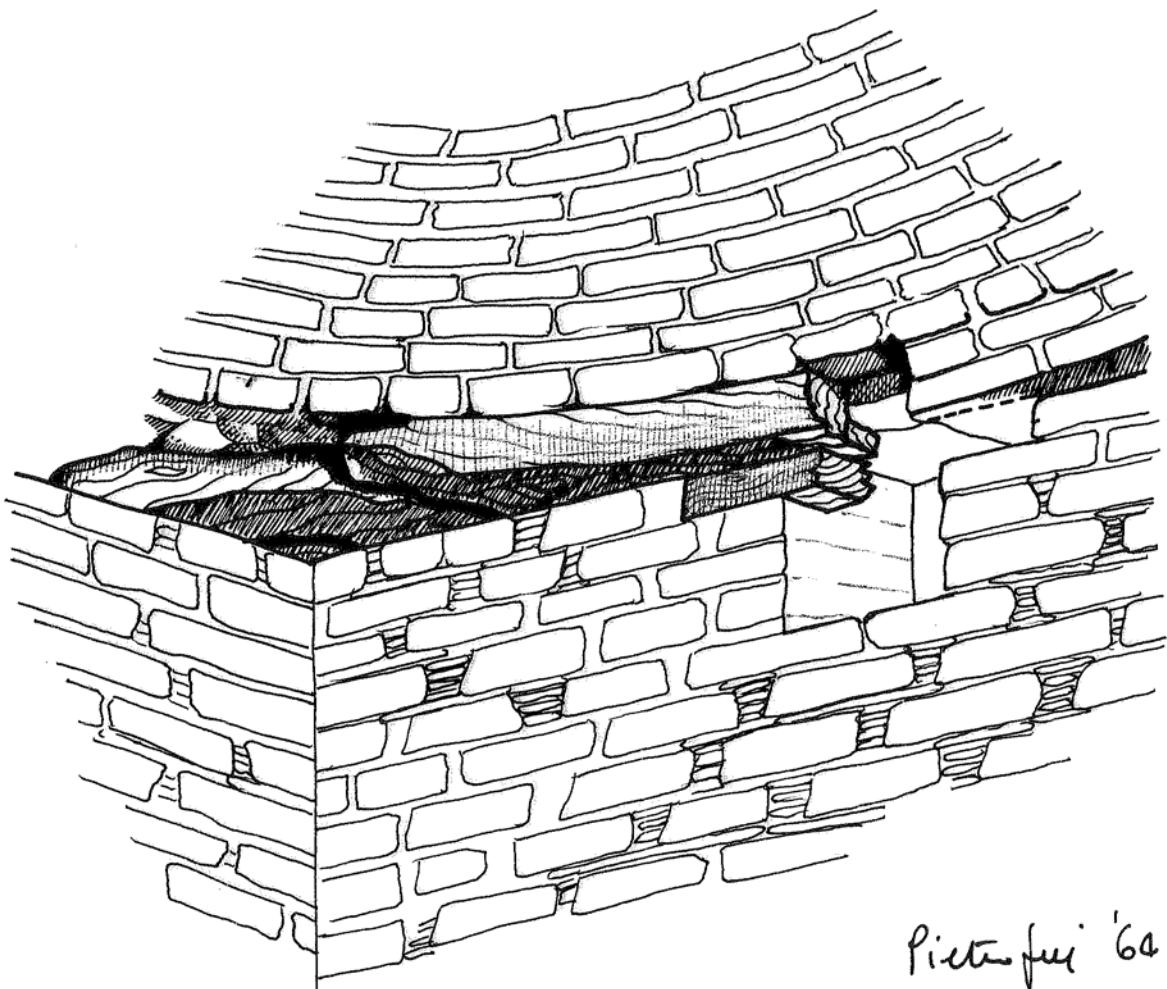

Fig. 489. Vihara of Gumbat. Sketch perspective drawing of a corner of the vault springer. (Gui 1964).

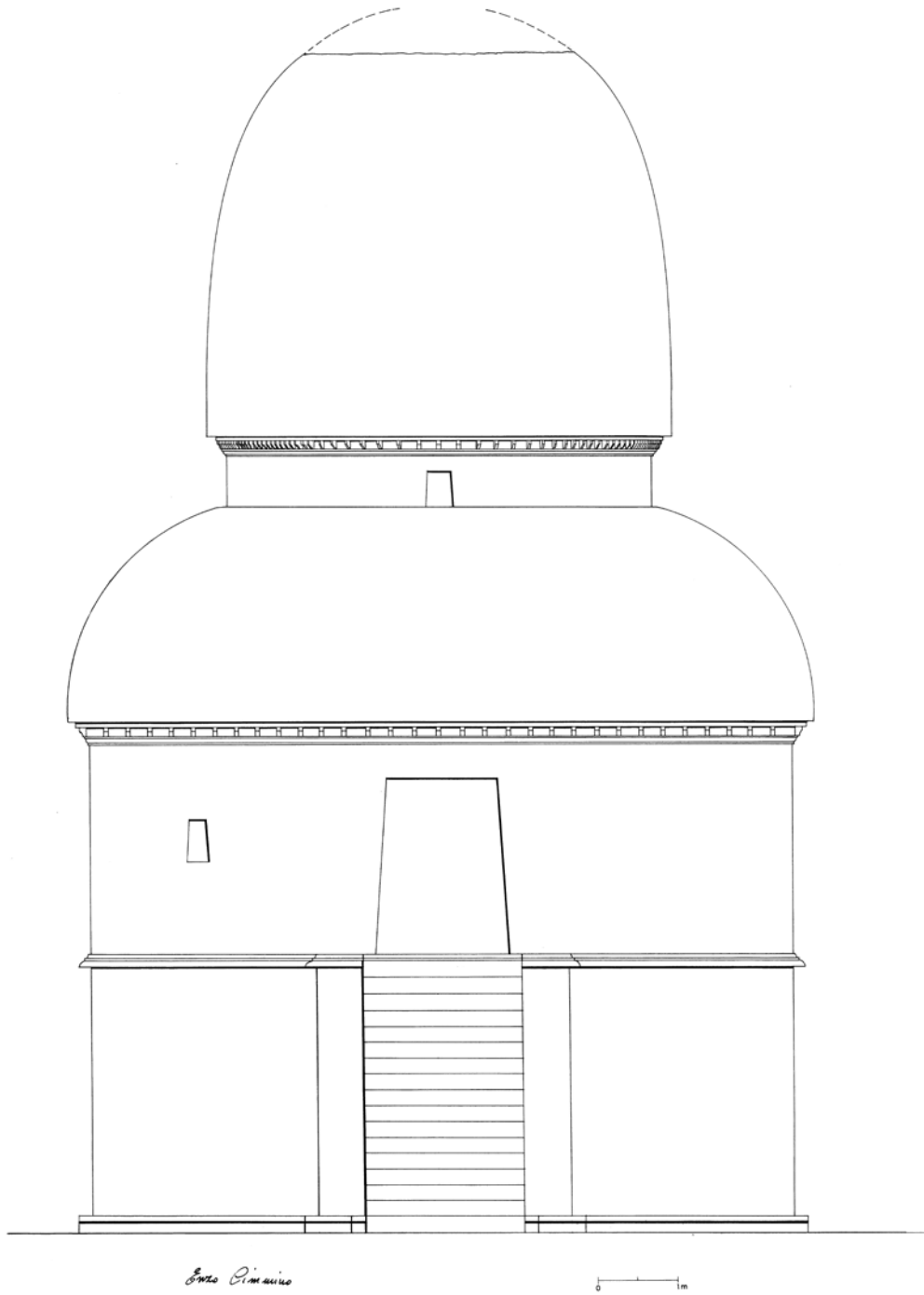

Fig. 490. Vihara of Gumbat. E side reconstructed elevation. (Cimmino 1964).

B. Viharas

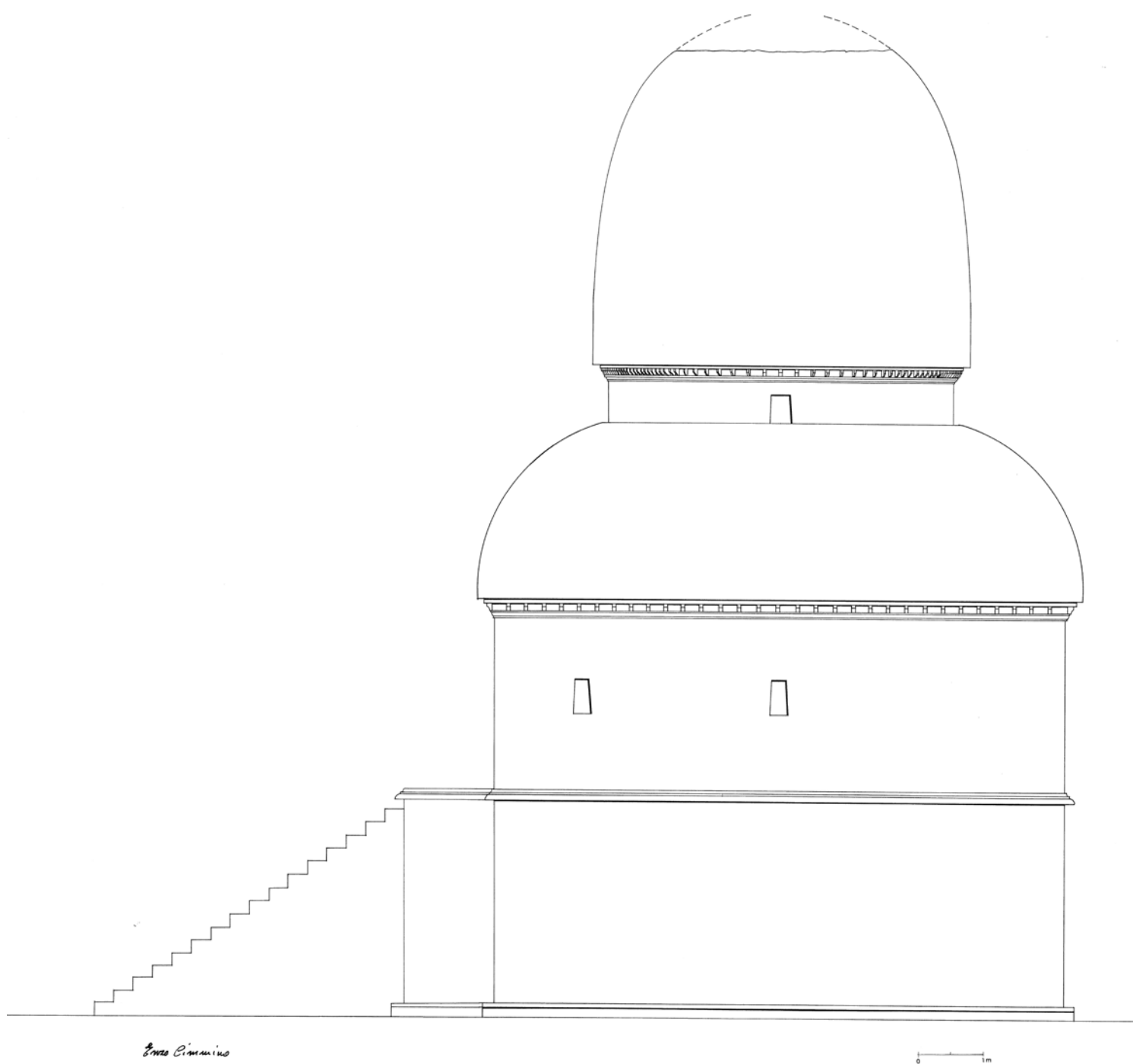

Fig. 491. Vihara of Gumbat. N side reconstructed elevation. (Cimmino 1964).

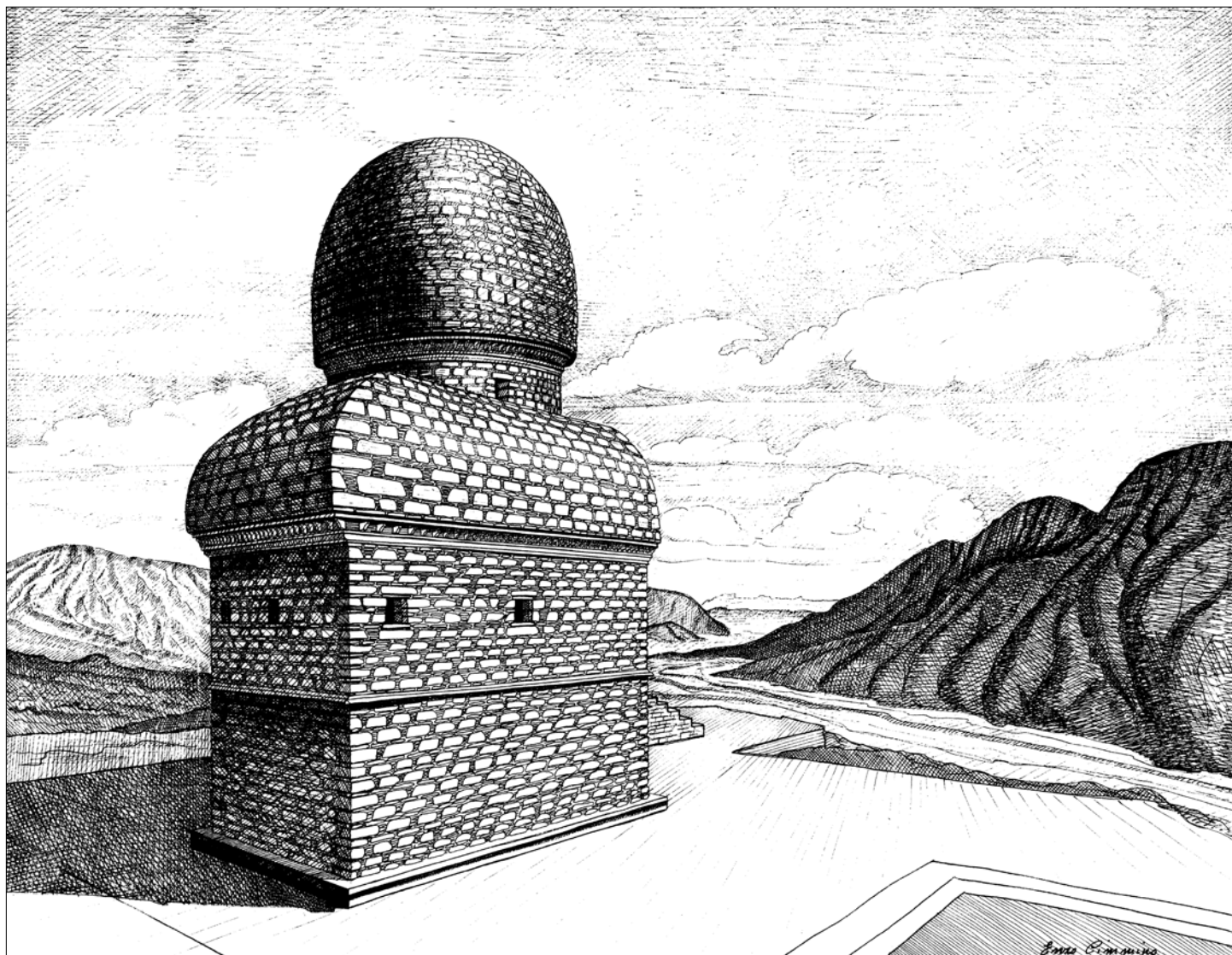

Fig. 492. Vihara of Gumbat. Reconstructed perspective drawing from S-W. (Cimmino 1964).

B. Viharas

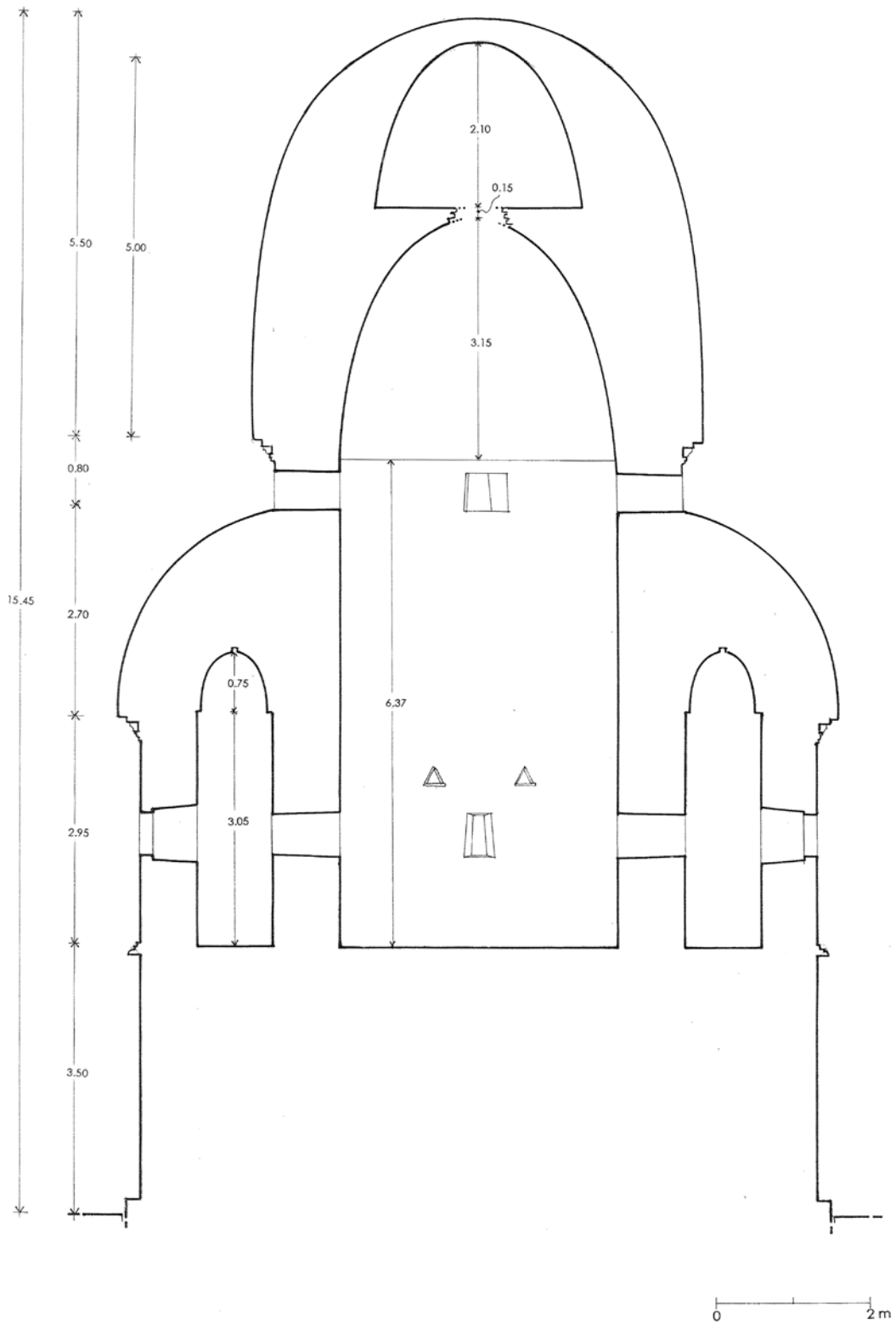

Fig. 493. Vihara of Gumbat. N-S cross section showing measures. (Gui 1964; Martore 2004).

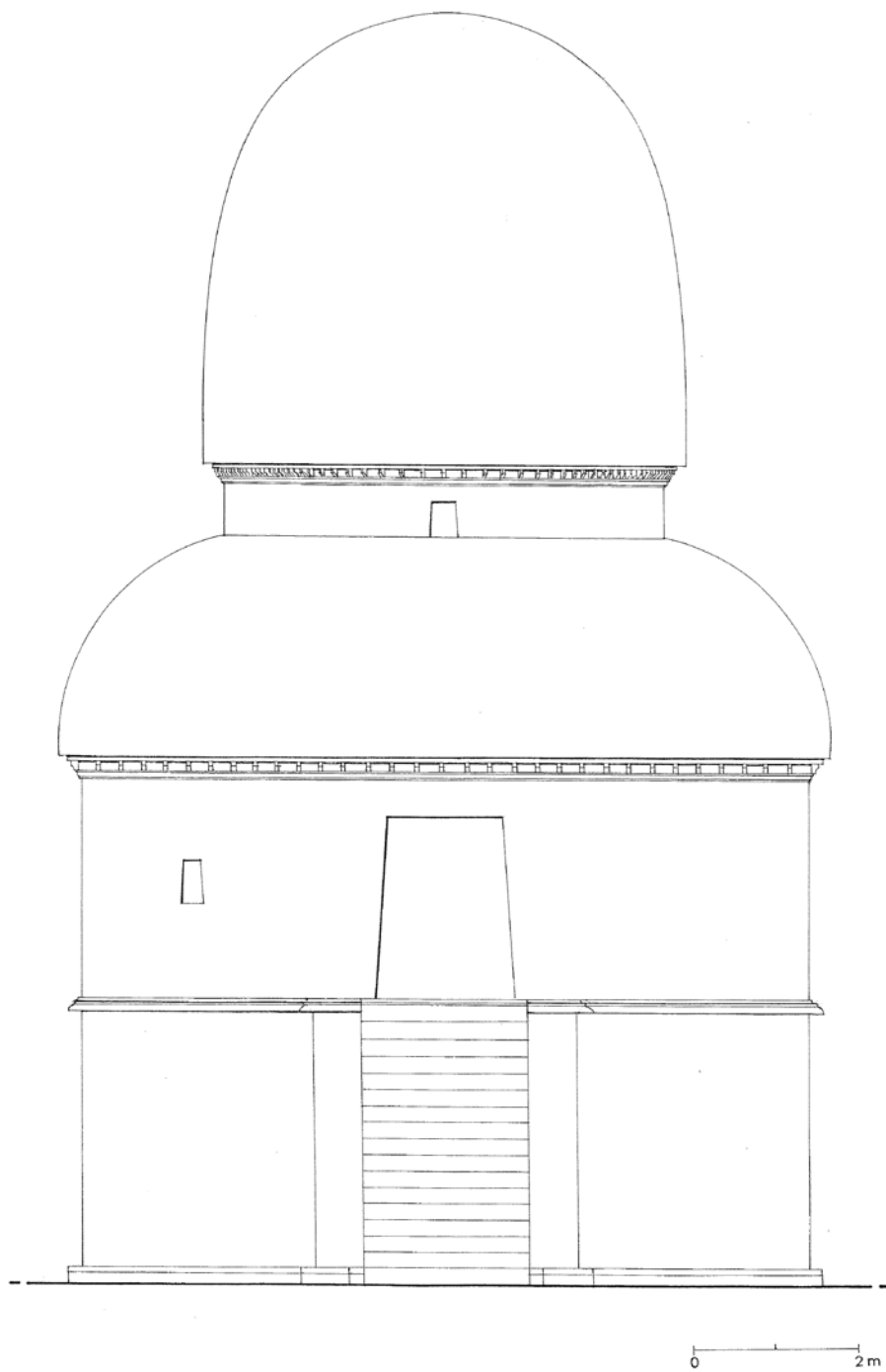

Fig. 494. Vihara of Gumbat. E side reconstructed elevation. (Cimmino 1964; Martore 2004).

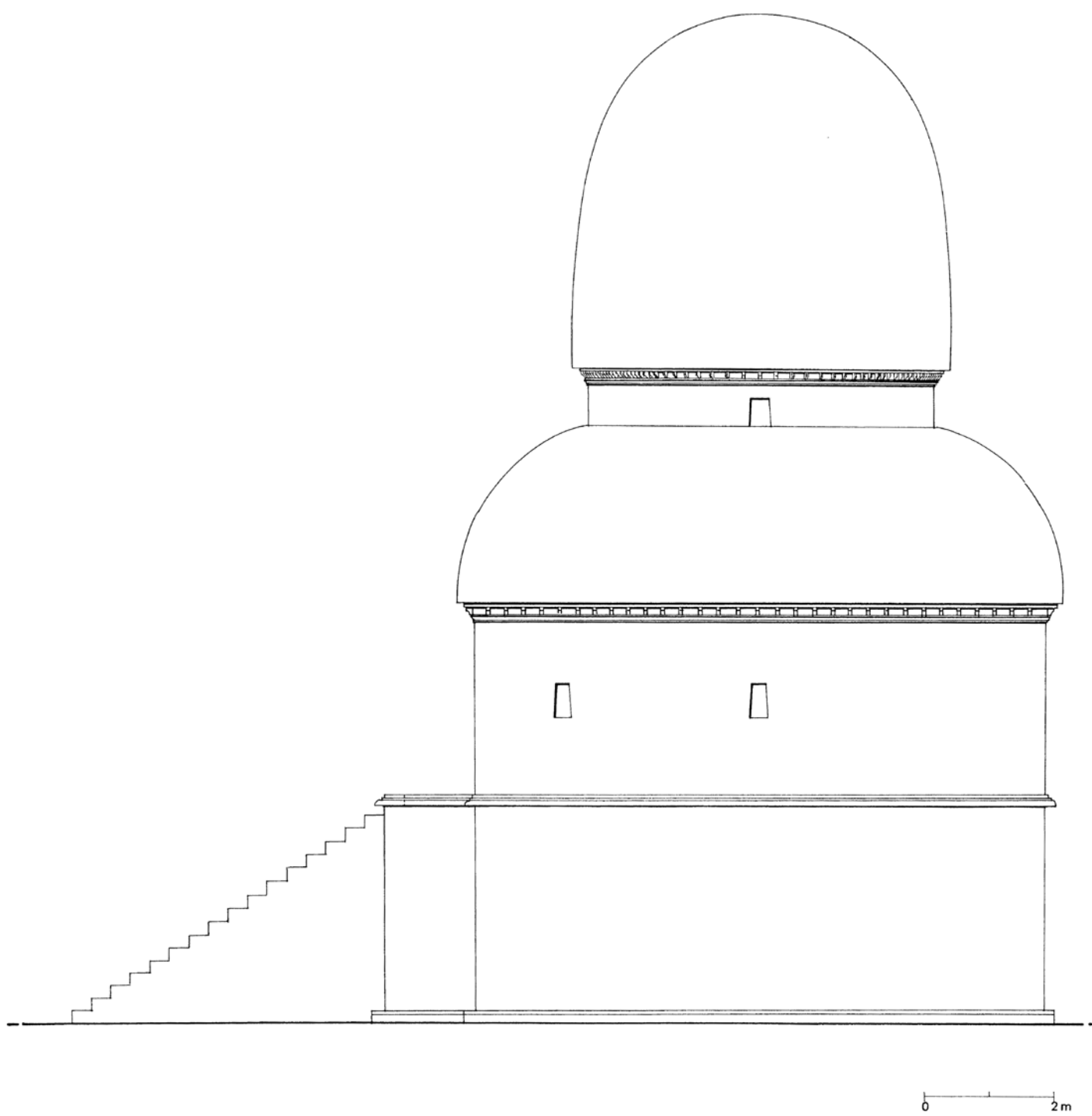

Fig. 495. Vihara of Gumbat. N side reconstructed elevation. (Gui 1964; Martore 2004).

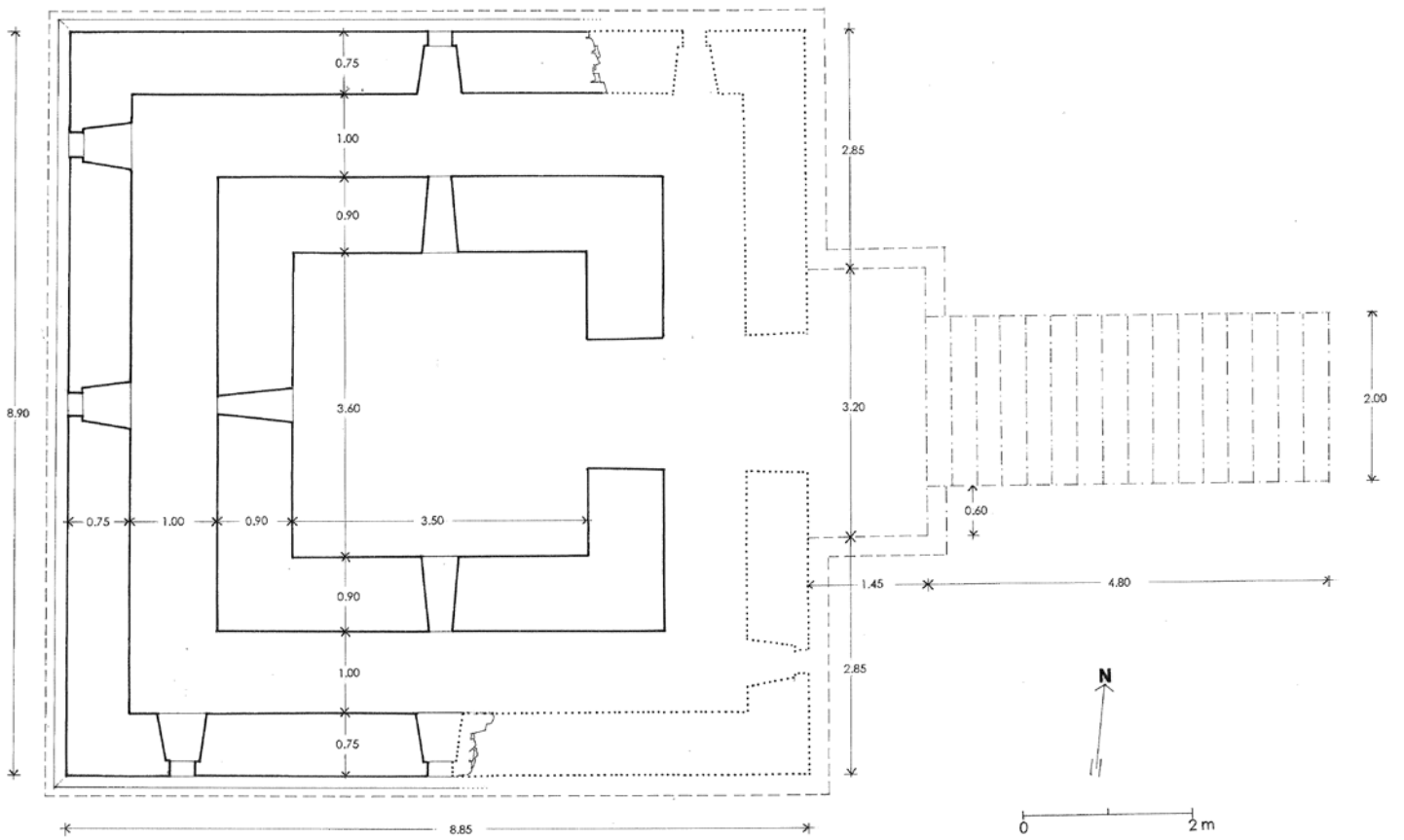

Fig. 496. Vihara of Gumbat. Plan showing a horizontal cross section at the level of the first row of the windows, showing the measures. (Gui 1964; Martore 2004).

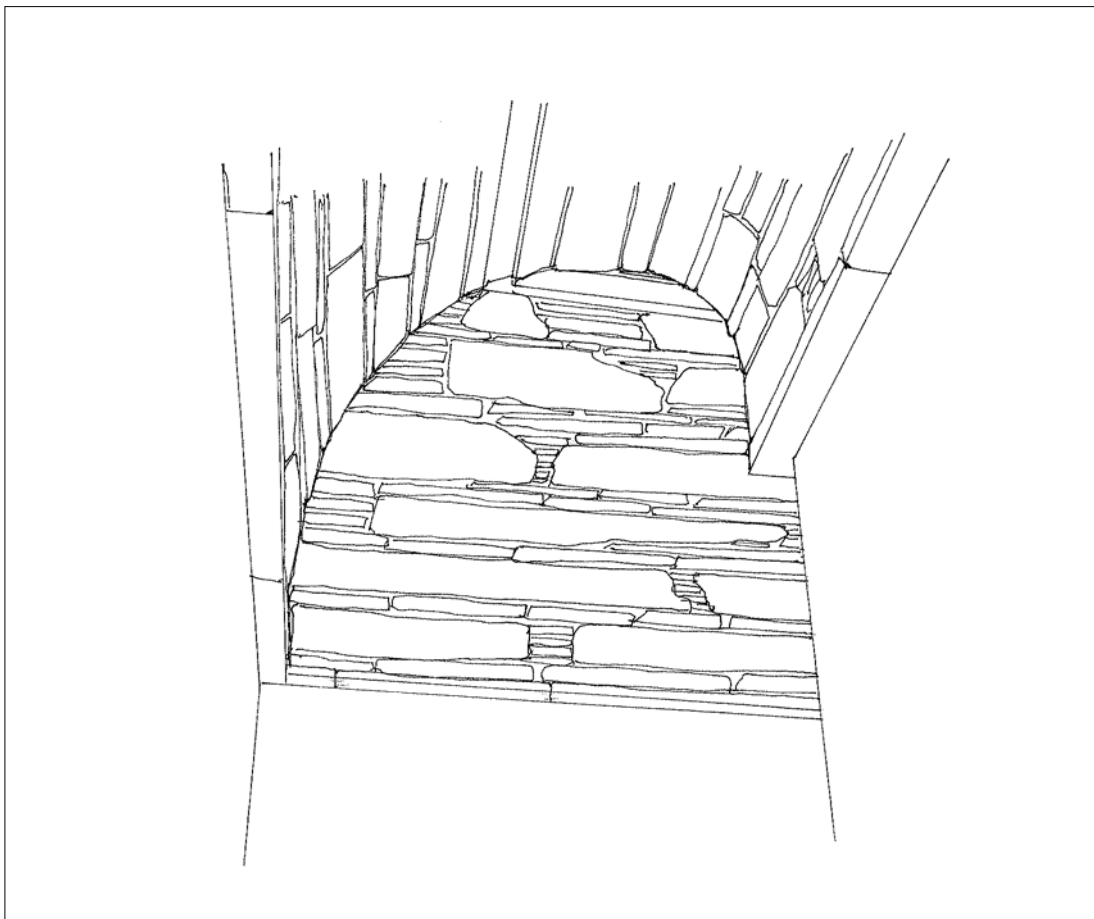

Fig. 497. Vihara of Gumbat. S corridor, perspective drawing of the vault. (Martore 2004).

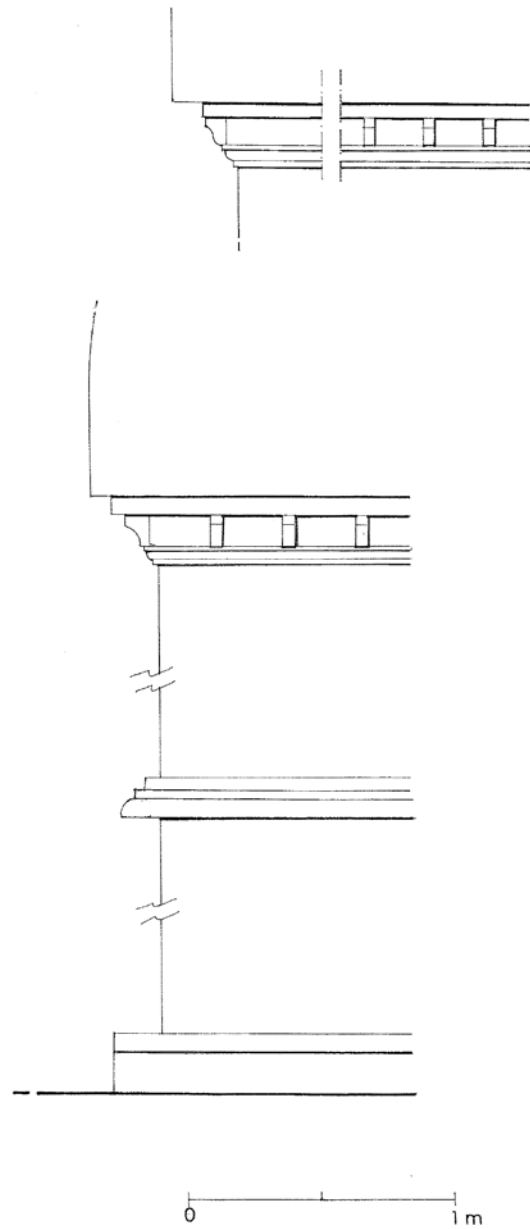

Fig. 498. Vihara of Gumbat. Podium and outer wall of the cell, and detail of the cornices (profile and elevation). (Gui 1964; Martore 2004).

B3. Vihara of Kanjar Kote

(Figs. 437-454)

The Site

Zone of Barikot.

Position: Lat. 31° 39' N; Long. 72° 10' E; SPM 43 B/2.

Proceeding up the Kandak valley, about 4 km from Barikot, on the right, on the slopes of the mountain extending from NW to SE lies the sacred terraced Buddhist complex of Kanjar-kote.

Bibliography and Documentation

Stein 1929: 31 ⁽¹⁾; 1930: 14, pl. 1 top right (map of the area) ⁽²⁾.

⁽¹⁾ 'A couple of miles higher up I found the ruins of a large sanctuary with chapels and monastic quarters, known as Kanjar-kōṭe, the "dancer's mansion", stretching on different levels for some hundred and seventy yards, below frowning cliffs of red sandstone. Here, too, there was evidence of vandal destruction, due to the search for "Būts", i.e. idols, for sale to collectors or dealers in British cantonments. The contrast offered by this wild solitude, a small Thebais, to the smiling green fields below was strangely impressive in the evening'.

⁽²⁾ 'Ruined monastery of Kanjar-kōṭē — On returning from this ruin late in the day I visited the site known as *Kanjar-kōṭē* lower down in the valley. There at a distance of about two and a half miles to the south-west of Bīr-koṭ village and on the eastern side of the rocky ridge below which lies the village of Abūwa, there extends a complex of badly decayed ruins on terraces, walled up in parts. The lowest of them lies about 150 feet above the fields of Malkidam; above them rise boldly eroded cliffs of red sandstone looking like frowning walls. The contrast offered by this wild solitude, a small Thebais, to the smiling green fields below was strangely impressive in the evening.

'The lower and main series of the terraces stretches, as seen in the rough sketch plan, pl. 1, for about 110 yards from NW. to SE. and is occupied by what obviously are the remains of a large Buddhist establishment. On the terrace A first reached from below it was just possible to trace indications of what evidently was a court once containing small Stūpas. It was surrounded in parts by chapel-like niches holding images, much after the fashion of the large chapel court found among the ruins of Takht-i-Bāhē. Of two of these "chapels" the walls, 10 feet high and flanking recesses 5 feet wide, are still more or less intact. Near them a low circular mound, about 21 feet in diameter, probably marks the base of a completely wrecked Stūpa. The position of another still smaller Stūpa could be made out in the western corner of this terrace. This terrace and the one adjoining westwards on a somewhat higher level are everywhere covered with heaps of stone debris, marking the position of destroyed structures. Several were probably of large size and may have contained monastic halls and dwellings. They are aligned on what seems to have been a road traversing the whole area'.

Barger & Wright 1941: 15-16, pls.II.1 (view of stupa), XI.1 (plan view of area showing excavation trenches), XII (plan of Barikot area with indication of the location), page 57 (list of material found) ⁽³⁾.

Tucci 1958: 315; mention with reference to Stein and to the excavations by Barger and Wright.

Faccenna 1959: reconnaissance and inspection of the structures; no graphic or photographic documentation.

Scerrato, Bonardi Tucci, Taddei, Vallazza 1959: photographic reconnaissance.

Tamagnini 1966: graphic survey.

Olivieri and Vidale 2000, 2004: photographic reconnaissance and description.

The site has been included in the Archaeological Map of the Swat Valley (Olivieri & Vidale 2006: 107-108, fig. 59).

⁽³⁾ *Excavations at Kanjar Kote* — Close under the ridge on the western side of the valley, about 3 miles from Barikot, are a group of ruins known as Kanjar Kote (plan, plate XI, 1). The surface remains were surveyed by Sir Aurel Stein in 1926, but for the sake of convenience they may again be described here. For 100 feet below the crest of the ridge, the hillside is covered with walled terraces on which the foundations of buildings can still be traced. Most of these are now mere heaps of debris, but it was possible to identify here and there rows of tall niches, and one or two vaulted chambers were standing almost intact, though half-filled with stony detritus. The lowest series of terraces extends for about 100 yards north-east and south-west, and was occupied, as the surface remains showed, by a group of monastery buildings on the usual Gandhāran plan. At the north-east end was a courtyard (A) containing a stūpa, and partly surrounded by domed niches like those in the chapel court at Takht-i-Bahi, though all but two of them had completely collapsed. From the south-west corner of this court a roadway, flanked by high niches set back on broad platforms of masonry rising 3 or 4 feet above the level of the road, led past the entrance of a second court (B) and thence to the upper terraces. A gully which bounds the whole complex of buildings on the west side is probably the bed of a stream now permanently dried-up. The enclosure (B), with a level grassy floor from 2 to 3 feet below the level of the roadway, had plainly been an open court devoid of buildings. Along its western side, the roofs of stone cells could just be traced projecting about a foot above the level of the road. The surface of court (A) was a welter of broken masonry, in the middle of which a mound of large stones rising several feet above the surrounding chaos, indicated the remains of a stūpa. On the eastern side of the court, shallow burrows intersecting the piles of stones, and a few pieces of battered schist carving scattered about on the surface, showed that local diggers had been there hunting for sculpture. In the course of their search they had uncovered a patch about 9' long and 3' deep of the masonry facing of the square of the stūpa, and part of the steps in the middle of its eastern side. Above the square base, traces of a round base could just be made out in the mass of fallen stones which was all that remained of the drum of the stūpa. The surface of the courtyard on the western side of the stūpa was apparently untouched, and we decided to start by clearing this area; subsequently the northern and eastern parts of the court were also partially uncovered.

'The masonry of the square base of the stūpa, which measured 31' square, was almost intact, and retained large patches of a covering of white plaster. The pavement was reached at 7' below the surface. On the western side of the large stūpa a row of small stūpas was uncovered, irregularly aligned at distances varying from 2'3' to 4'9' from the base of the main stūpa (plate II, 1). On two of them part of the original drum was still standing, but on the rest, as on most of those subsequently discovered, everything above the square base had crumbled. Part of a modillion cornice in stucco was still clinging to the base of one of these stūpas, and small pieces of stucco mouldings were found in the debris that surrounded them.

'[...] Clearance of north-eastern part of the court (A) revealed further rows of small stūpas [...]. At the western corner of the court one of the domed cells already mentioned was excavated and was seen to be a square chamber, like the cells in the lower courtyard at Takht-i-Bahi, 9' high from its stone floor to the centre of the domed roof, with a door 2' high giving onto the court.

'Apart from the two courtyards, two of the separate cells were cleared of debris but nothing was found in them'.

The Area and the Viharas

The area was described by Stein, who mentions two terraces, A and B, standing on two levels and with supporting walls, a few particularly well conserved buildings and other scattered structures above them; later by Barger and Wright, who dug several excavation trenches to recover sculptures.

To these descriptions it seems worth adding a few brief observations made by Faccenna (1959) during an inspection. We transcribe them here. The surveying of the better conserved monuments was performed during a further reconnaissance by Tamagnini in 1966, whose sketches are presented herein (revised by Martore 2003 as regards the graphic rules).

B3.1. Double Vihara (Figs. 504-512)

Two have been conserved side by side, as reported by Stein and Barger and Wright. They form a single unit; they stand on a single podium and have a single roof covering. They are separated by a shared wall. Their anterior part with the covering is missing. Each cell has slightly tapering inner lateral walls; the rear one has a small rectangular window on top. At the top of the walls there is a row of protruding slabs on which the vault is supported. The vault has four folds that are brought together on top with semicircular slabs on the inside and whole slabs above this, thus closing all apertures.

On the outside, the tall smooth podium, which is continuous below with the substruction wall, is closed by a simple reverse ovolo cornice. The wall of the cell body ends in a cornice with rigid profile brackets between two fillets. The cornice acts as the springer for the roof covering with its four oblique sloping folds in the shape of a truncated rectangular-plan pyramid.

This is a new type of vihara which may be defined as 'double'; just as for Swat the type of vault with four 'curved slopes' is new, at least as far as what has been conserved and is known is concerned.

In plan view the double vihara measures 4.20 in leng., 2.00 in max. conserved depth, with a h. above the podium as far as the probable reconstruction of the roof cover of 3.675. Each cell is 1.50 wide and (wall and vault) 3.45 tall.

The current situation (2000-2004) regarding the area is shown in several photographs. Several of these document the conditions of the double vihara with only the left cell remaining and lacking the roof covering.

B3.2. Vihara circular in plan

(Figs. 513-517)

Side by side with this vihara is a circular vihara, 4.60 in external diam., with walls 0.65 thick; the N wall flares inwards and has antas protruding outwards, to which corresponds a raised step leading to the inner paved and plaster-covered storey ⁽⁴⁾.

On the SW side there is a window with walls flaring inwards. Plaster traces are visible also on the outer wall. Towards the S, on the valley side, there are supporting or retaining walls with a series of progressively projecting and sloping offsets (thickn. 0.40, 1.40).

⁽⁴⁾ For the sake of comparison, see B4. Vihara of Gumbatuna.

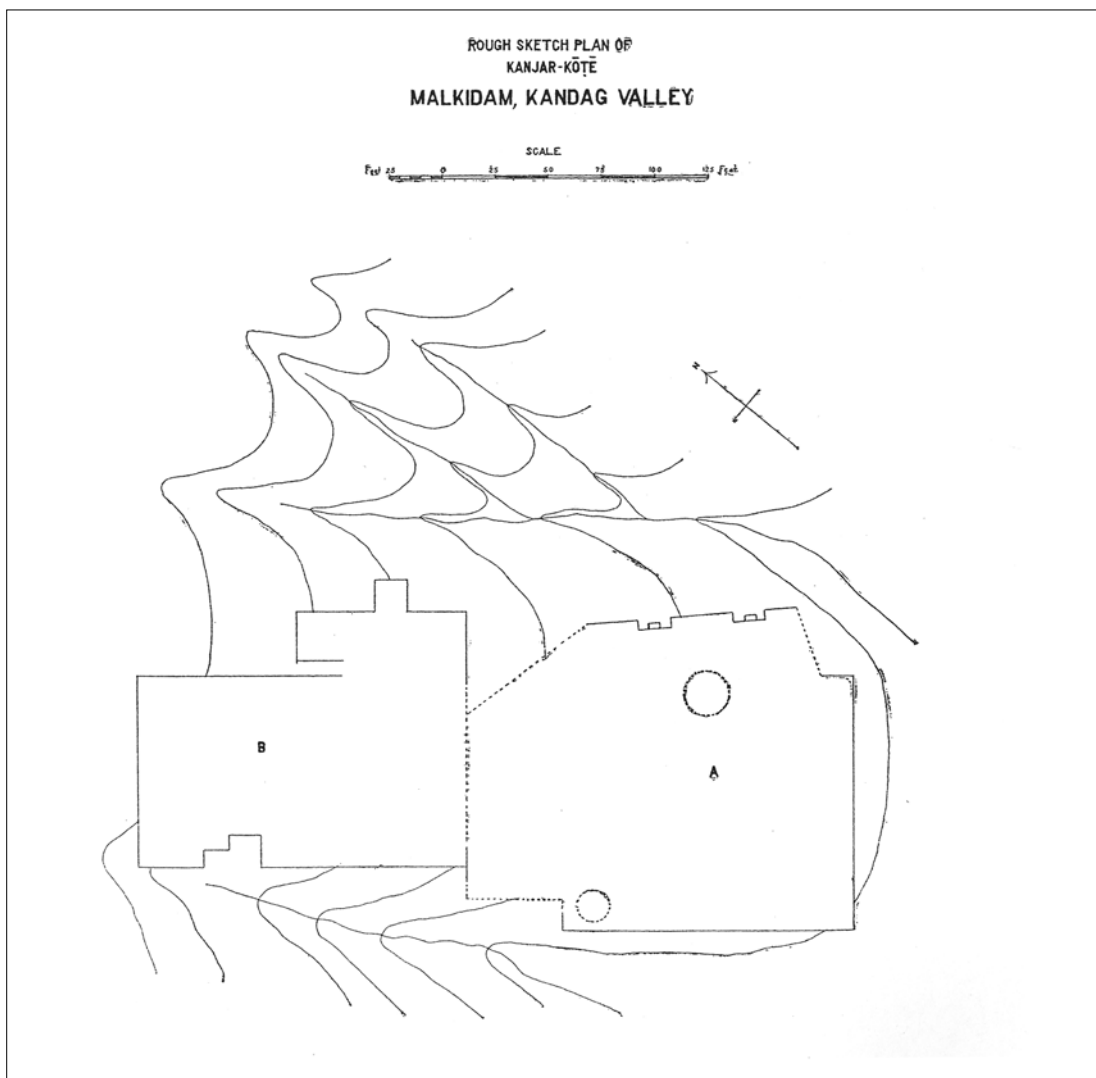

Fig. 499. Kanjar-Kote. Sketch plan. (After Stein 1930: pl. 1, on bottom right).



Fig. 500. Kanjar-Kote. View of the Kandak valley from Kanjar-Kote. (Taddei 1959; Neg. CS).



Fig. 501. Kanjar-Kote. Substruction structures. (Taddei 1959; Neg. CS).



Fig. 502. Kanjar-Kote.
Substruction structures. (Taddei
1959; Neg. CS).



Fig. 503. Kanjar-Kote. Substruction structures. (Taddei 1959; Neg. CS).

B. Viharas



Fig. 504. Kanjar-Kote. Double vihara. N side with podium, substruction wall, cell and covering roof. (Taddei 1959; Neg. CS).



Fig. 505. Kanjar-Kote. Double vihara. S side (front). (Bonardi Tucci 1959; Neg. CS).



Fig. 506. Kanjar-Kote. Double vihara. S side (front); left cell (W). (Bonardi Tucci 1959; Neg. CS).



Fig. 507. Kanjar-Kote. Double vihara. Left cell (W), W outer side. (Bonardi Tucci 1959; Neg. CS).



Fig. 508. Kanjar-Kote. Double vihara. Left cell (W), pavilion vault. (Bonardi Tucci 1959; Neg. CS).



Fig. 509. Kanjar-Kote. Double vihara. E cell, pavilion vault. (Bonardi Tucci 1959; Neg. CS).



Fig. 510. Kanjar-Kote. Double vihara (in 2000); E cell and the covering roof are missing. (Vidale 2000).

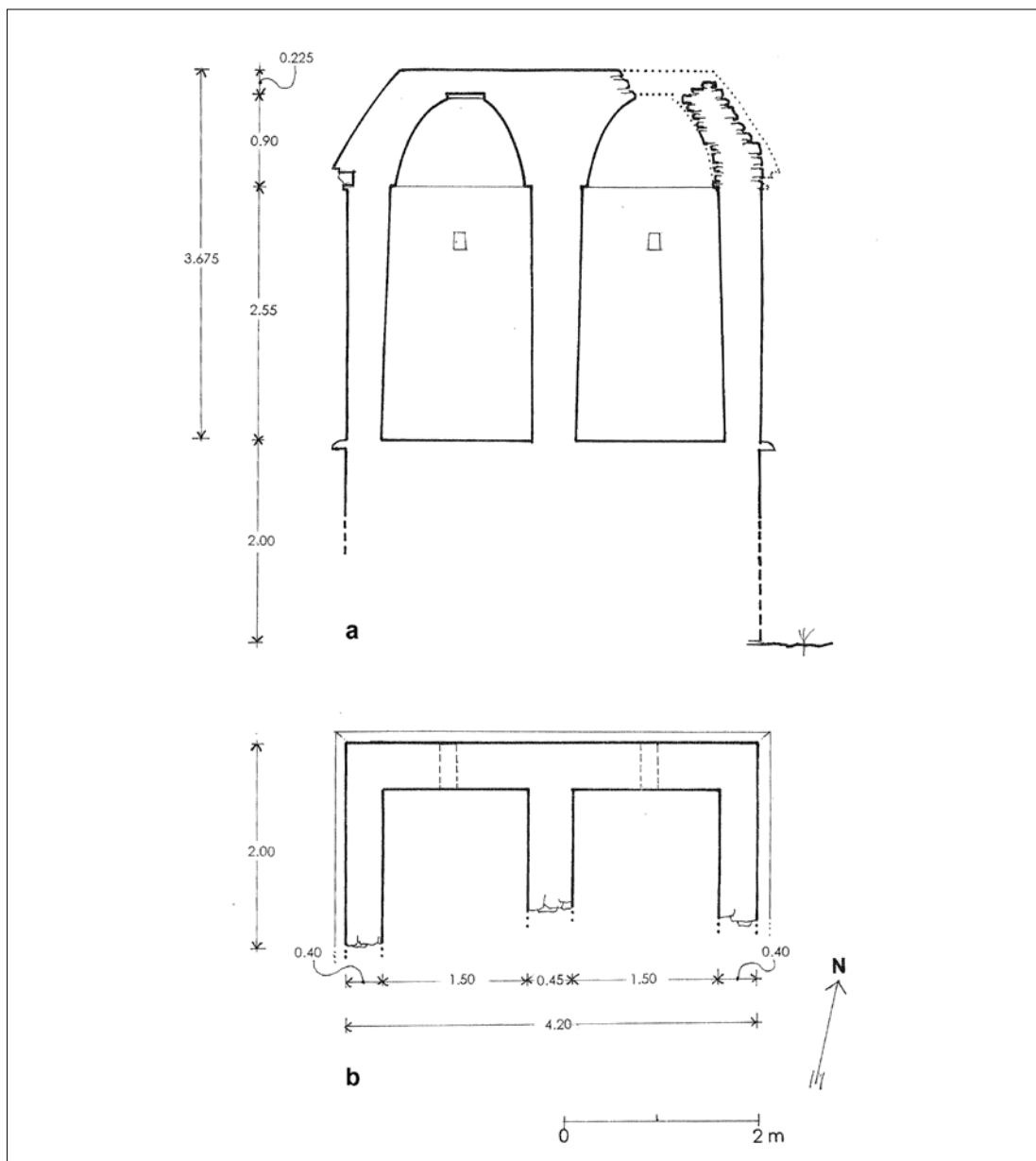

Fig. 511. Kanjar-Kote. Double vihara. *a.* E-W cross section. *b.* plan. (Tamagnini 1966; Martore 2004).

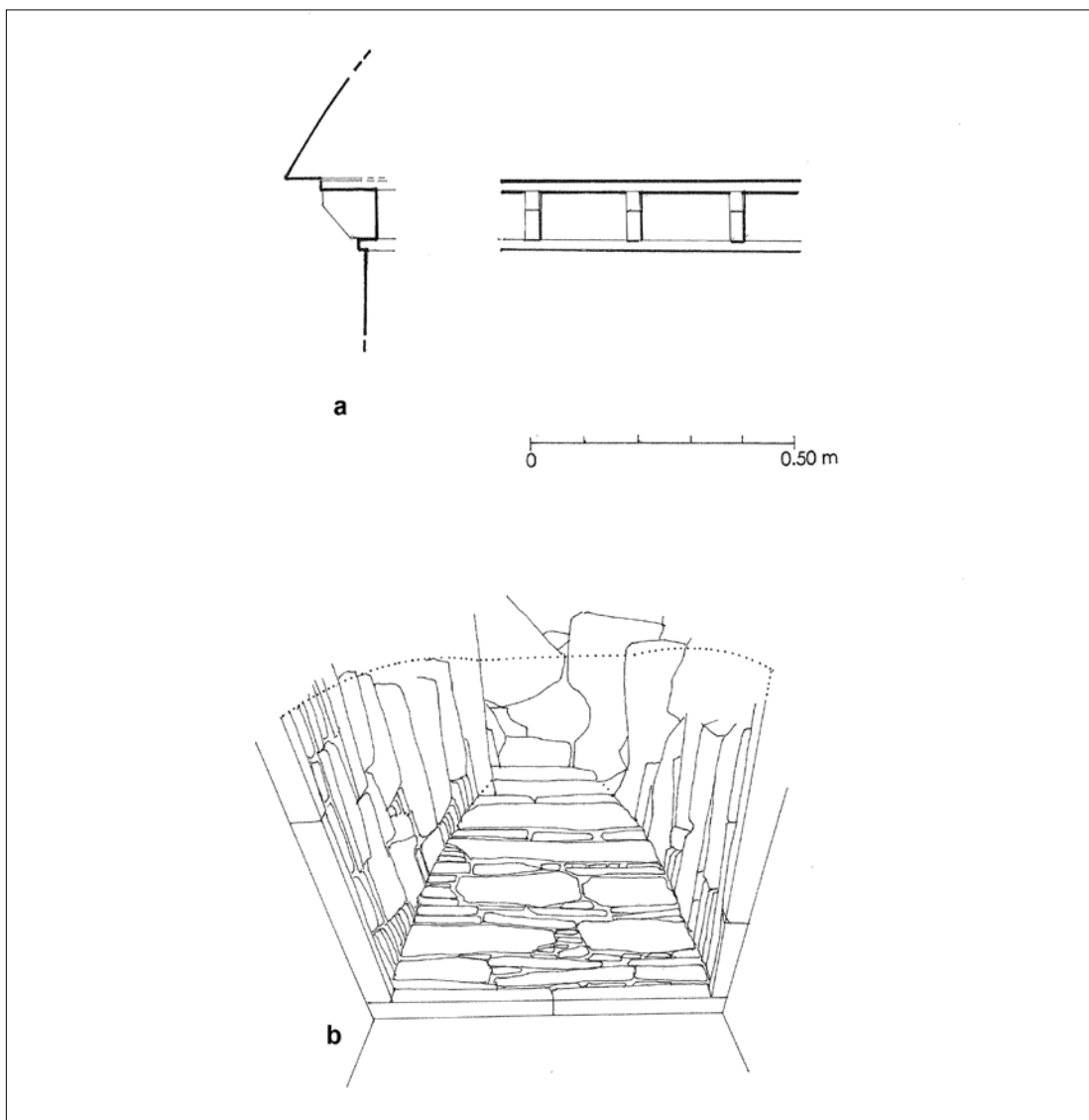

Fig. 512. Kanjar-Kote. Double vihara. *a.* detail of the cell cornice, profile and elevation. *b.* axonometric projection of the vault of one of the two cells. (Tamagnini 1966; Martore 2004).

B. Viharas



Fig. 513. Kanjar-Kote. Circular vihara. Cell, outer wall of E side with reinforcement wall. (Taddei 1959; Neg. CS).



Fig. 514. Kanjar-Kote. Circular vihara. Wall of the E side cell. (Bonardi Tucci 1959; Neg. CS).



Fig. 515. Kanjar-Kote. Circular vihara. W entrance. (Bonardi Tucci 1959; Neg. CS).

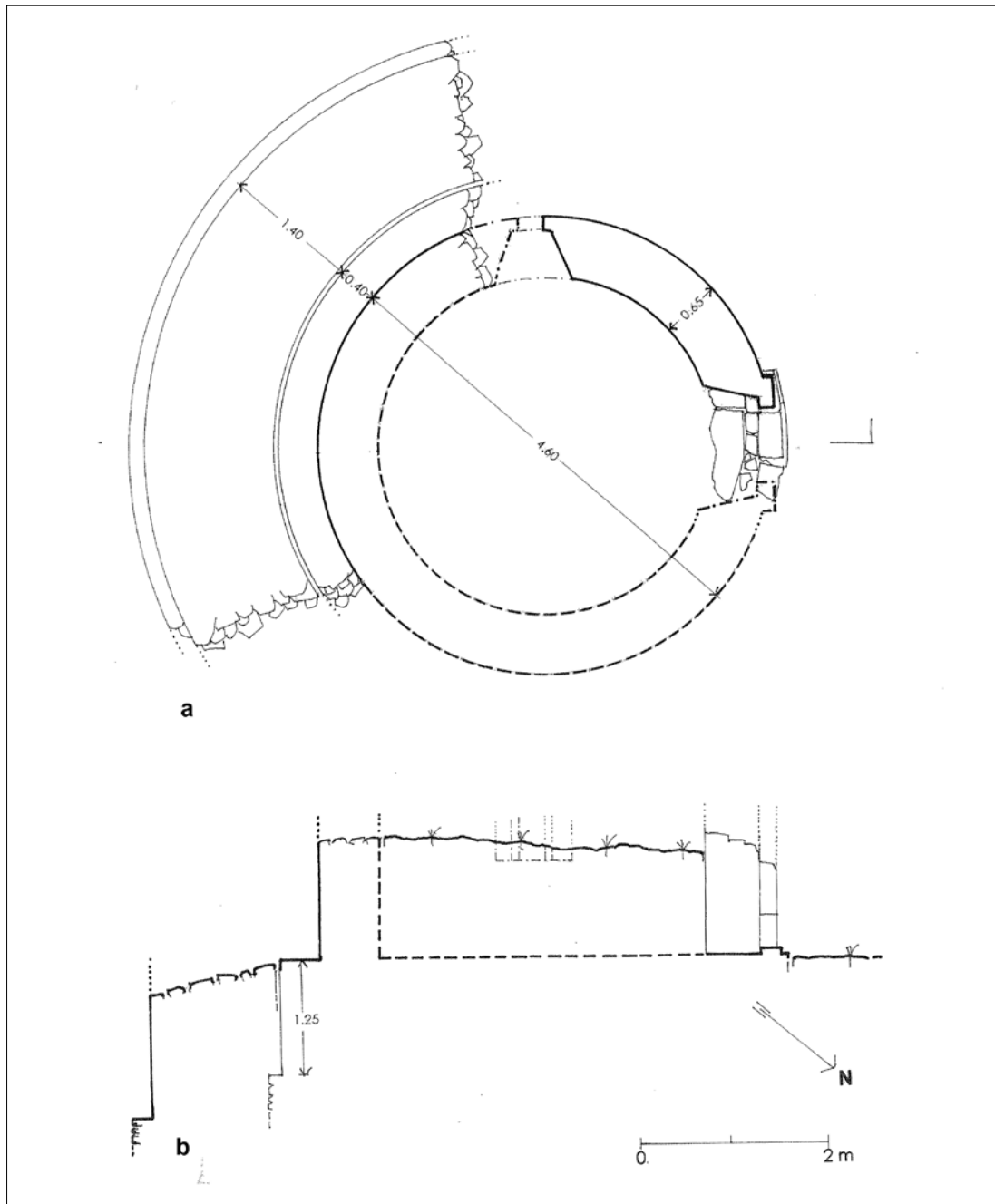

Fig. 516. Kanjar-Kote. Circular vihara. *a.* plan. *b.* E-W cross section. (Tamagnini 1966; Martore 2004).

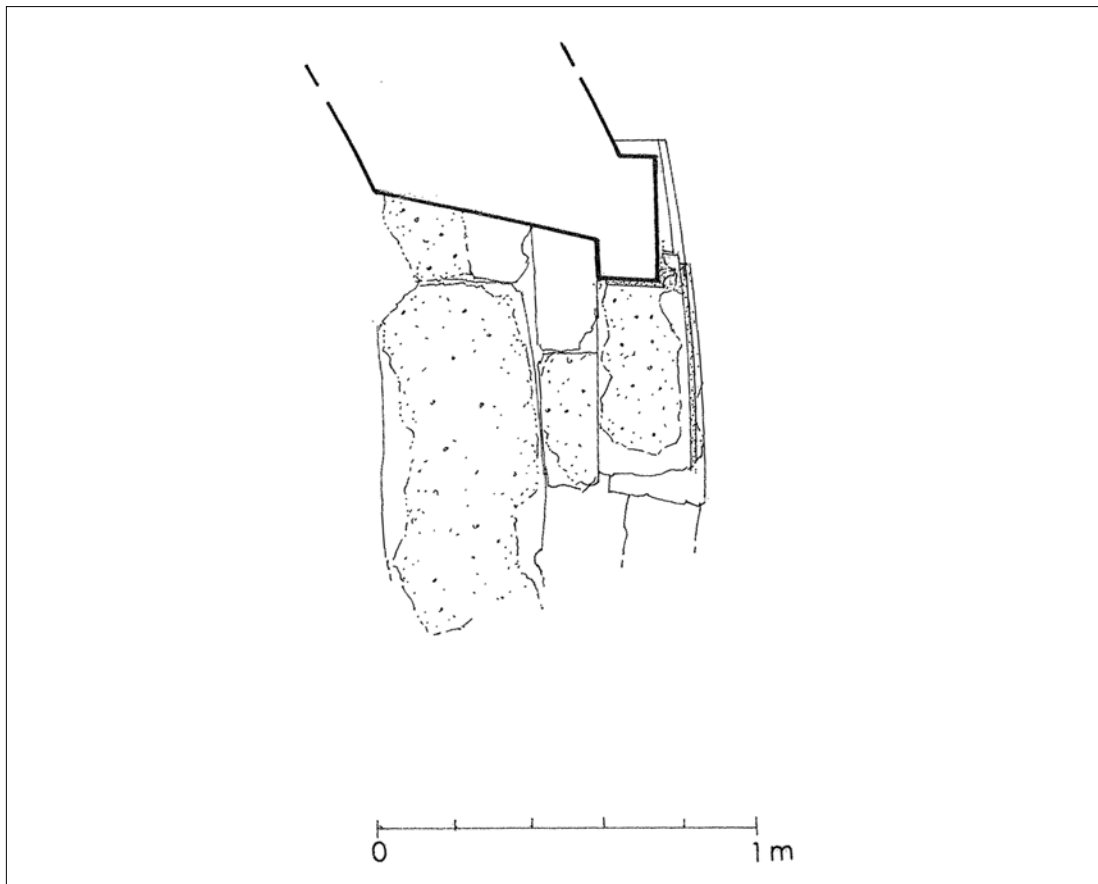

Fig. 517. Kanjar-Kote. Circular vihara. Plan showing the opening of the cell. (Martore 2004).

B4. Vihara of Gumbatuna

(Figs. 518-524)

The Site

Zone of Gumbatuna.

Position: Lat. 34° 41' N; Long. 72° 11' E; SPM 43 B/2.

Among the monuments included in the rich and important archaeological zone of Gumbatuna, in addition to the sacred area with the main stupa, there is also a vihara located NE of the village.

A short description will be given here, accompanied by photographs and surveys, in order to avoid the total loss of the memory of this monument which no longer exists.

Bibliography and Documentation

Stein was the first to observe and describe it during his visit to Gumbatuna in 1926 (1930: 11, fig. 5) ⁽¹⁾.

Barger and Wright in 1938 visited Gumbatuna (1941: 27) attracted by the idea of seeing it ⁽²⁾.

The year 1960 witnessed the inspection by Faccenna with Taddei and Ms F. Callori di Vignale, restorer, and a second one in 1966 ⁽³⁾.

⁽¹⁾ '[...] in a small ravine to the north-east at a distance of some 150 yards from the mosque [of the village] there is found a small circular shrine in comparatively fair preservation (fig. 5). The little rotunda has an interior diameter of 14'9" and still carries a rather flat dome partly intact. Its walls, 3 feet thick, rise 16 feet above the surface of the debris-filled interior. This may well hide remains of stucco images of Buddhist divinities such as are likely once to have stood in this little Vihāra. On the south the wall descends about 8 feet more, suggesting a total height of over 24 feet for the structure; the entrance to it faced north'.

⁽²⁾ 'They were attracted [...] especially to investigate the small circular shrine, discovered by Sir Aurel Stein in a small ravine north-east of the village. The interior of this had evidently been cleared, and the villagers told us that a few years previously a 'sahib' had dug out the debris and carried off the only piece of sculpture it contained'.

⁽³⁾ 'The circular-plan vihara has a forebuilding with door (steps?). The gap which opens up practically as

Tamagnini's survey dates to 1966.

In a recent visit, Faccenna (1993) observed that 'the vihara is now destroyed; a large house now stands in its place'.

Photographic campaigns have been carried out over time by Italian Archaeological Mission members.

The Circular Vihara

We shall now examine Tamagnini (1966) sketches with graphics updated by Martore (2003). The present description is based on them and on Faccenna's photos and reports and so some details are missing.

The vihara has a circular plan, and stands on a base that opens to the N; it has a raised dome with an ogival vault and a roof covering also circular in plan with sloping folds. The top of the roof covering and the upper part of the front wall with the door are missing; there is a gap in the S wall.

It was built using blocks, some of which parallelepiped shaped, others irregularly dressed, arranged in horizontal rows, with superimposed small slabs closing the gaps at the sides and with slightly larger slabs arranged in one or two rows separating the blocks above and below. For the vault and the roof covering obliquely cut superimposed slabs were used.

The building stands, slightly set back, on a tall smooth base which is partly buried and therefore not completely visible. It has a first storey with a simple torus moulding base, limited at the top by a small cornice with ovolo, protruding reverse ovolo and roofing slabs. It corresponds to the floor level inside. The cell (diam. 4.375) has walls 0.85 thick, 2.65 tall, running up as far as a slightly protruding band closed by a slab protruding even further and follows the vault starting from the springer. The vault was built using gradually protruding slabs having a sloping edge so as to form a continuous line. The room inside has a tot. h. of 6.00.

At the level of the protruding slab, on the outside, there corresponds a cornice composed of brackets with a rounded ovolo type profile, lying between two fillets. The highly protruding upper slab forms the starting base for the roof covering. Wider at the base, it tapers slightly as it rises towards the top. The closure at the top is indeterminable, and probably continued the line of the vault; this would exclude an upper covering, but not a probably small-sized element.

In the N wall there is an opening 1.25 wide with jambs splayed inwards (width 1.40) and protruding outwards on both sides. Between them is the beginning of an access stairway of which three/four steps are visible marked by several tread slabs

far as the top of the conserved dome is unsafe; the monument is splitting open; restoration is extremely urgent. Numerous plaster fragments lie around the entrance'.

and plaster remains. The number of steps is dependent on the original surrounding plan of which we know nothing and that might have varied according to the slope of the ground.

Comparisons

The vihara of Gumbatuna recalls similar constructions, circular in plan both on the interior and the exterior. As well as the preceding one of Kanjar Kote (B3.2) mention should be made of those reported by Foucher (1905-51: 124, figs. 38 and 39) and mentioned by Tarzi (2006), one at Guniyar-Cherat, and the other at Carkotlai, both in Swat. The first displays a wall bounded on top by a thin corbelled cornice between fillets. It acts as a springer for the (truncated?) cone-shaped roof covering which encloses a probable ogival vault.

This is found in the second vihara, enclosed by a vertical cylindrical structure around which there is an abutting stairway. At the top of the vault there is a cylindrical opening that is no doubt linked to the roof covering, the shape of which cannot be determined. It is perhaps reminiscent of the double roof covering with a room on top of the cell that was found in the vihara of Gumbat.



Fig. 518. Gumbatuna, Vihara. S and W sides. (After Stein 1930: fig. 5).



Fig. 519. Gumbatuna, Vihara. S side. (Faccenna 1960; Neg. CS).



Fig. 520. Gumbatuna, Vihara. SE side; upper part of the outer wall of the cell showing remains of plaster, cornice and the beginning of the dome. (Faccenna 1960; Neg. CS).



Fig. 521. Gumbatuna, Vihara. SW side; upper part of the outer wall of the cell showing remains of plaster, cornice and the beginning of the dome. (Faccenna 1960; Neg. CS).



Fig. 522. Gumbatuna, Vihara. S side; view of the valley from the cell, through the gap on the cell wall. (Faccenna 1960; Neg. CS).

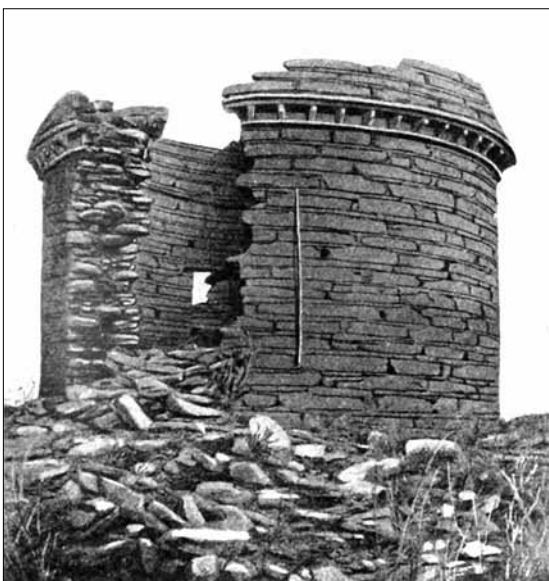

Fig. 523. Gunijar (Swat). Circular vihara. (After Foucher 1905-51: fig. 38).

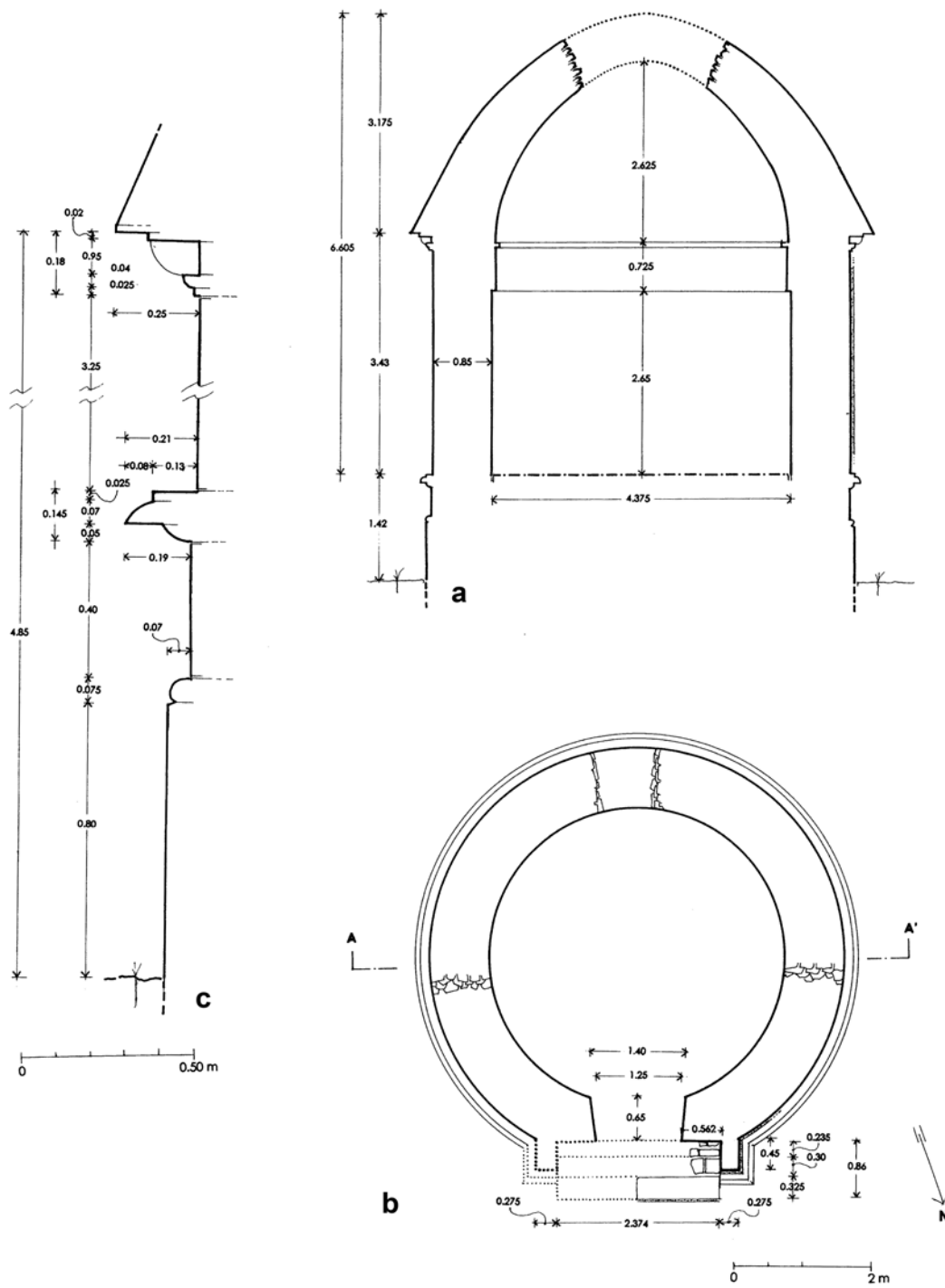

Fig. 524. Gumbatuna, Vihara. a. cross section. b. plan. c. profile; with the measures. (Tamagnini 1966; Martore 2003).

C.

DWELLING UNIT

C1. Dwelling Unit of Abbasahebchina

(Figs. 525-529)

The Site

Zone of Barikot.

Position: Lat. 34° 37' N; Long. 72° 13' E; SPM 43 B/2.

On the W slopes of the mountain stands a characteristic construction that, for want of a better definition, we can call a monk's dwelling unit.

Bibliography and Documentation

Surveyed by Caroli (1957); the sketch is repeated in Tucci 1958: 316, fig. 34.

It has been included in the Archaeological Map of the Swat Valley (Olivieri & Vidale 2006: 100).

Spagnesi 2006: fig. 12.

The Dwelling Unit

On a terrace supported by a wall with cornice, and standing at the centre, comparatively well conserved, is a rectangular building measuring 13.95 x N 5.10 and S 5.20. It comprises two rooms separated by a large vestibule, opening on to the porch closed on both sides and facing E.

Abutting this on the S side is a stairway leading to the upper level.

At the side of the latter a large niche opens with a raised ogival vault on the protruding part of the jambs; its corresponds in depth to the width of the stairway.

With their typical planimetric layout these buildings are quite common in the Buddhist sacred centres; more often than not they are situated on the outskirts, beside the terrace of the stupas and the monastery, as though to mark their separation and greater isolation. Mention should be made among others of those of Tokar Dara and, outside Swat, those of Takht-i-Bahi and Jamalgarhi.

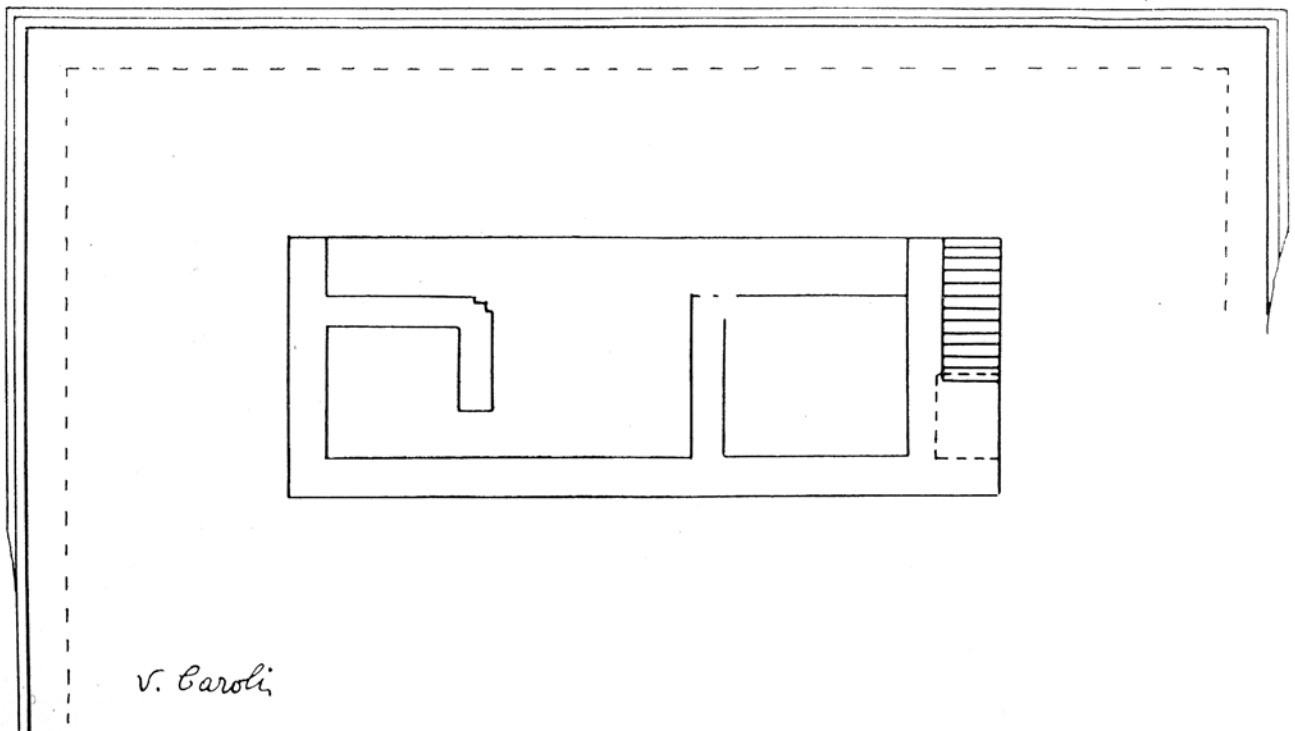
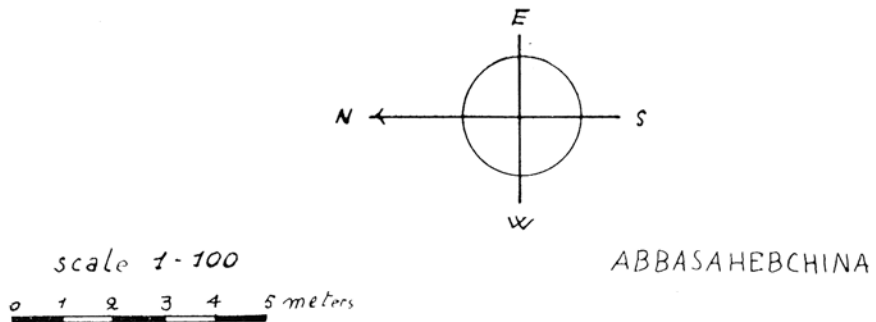

Fig. 525. Abbasahebchina, dwelling unit. Plan.
(Tucci 1958: fig. 34; drawing by V. Caroli, 1957).



Fig. 526. Abbasahbchina, dwelling unit. General view from the hill.
(Spagnesi 2006: fig. 12).



Fig. 527. Abbasahbchina, dwelling unit. S side, stairway with niche.
(Faccenna 1957; Neg. CS).



Fig. 528. Abbashehchina, dwelling unit. E side, stairway. (Faccenna 1957; Neg. CS).

C. Dwelling Unit

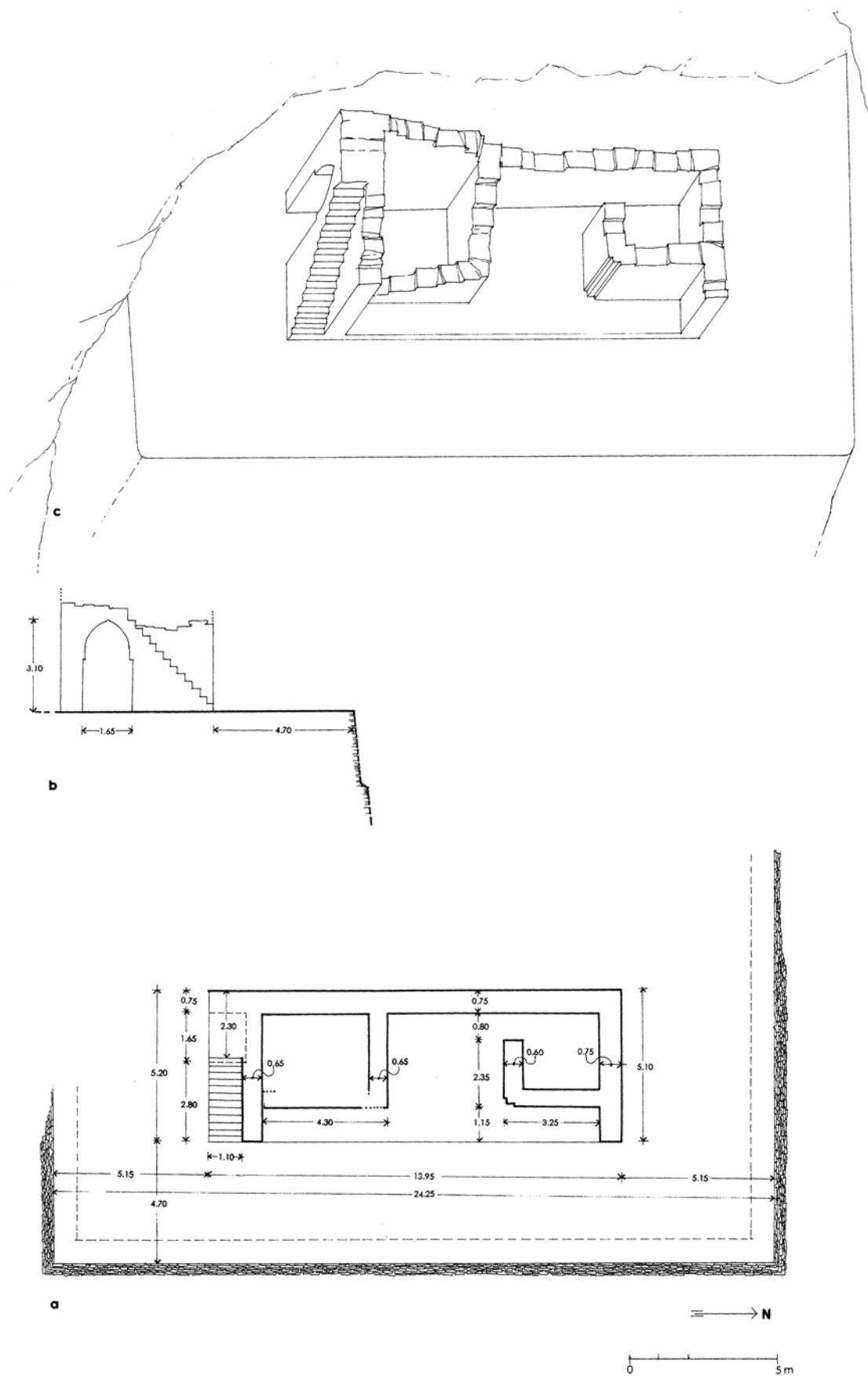

Fig. 529. Abbashehchina, dwelling unit. *a.* plan showing the measures. *b.* elevation of the S side with stairway showing the measures. *c.* axonometric view. (Caroli 1957; Martore 2003).

Conclusions

(Figs. 530-532)

Stupa

General Features

In the typological examination of the stupas it was deemed appropriate to maintain their grouping in homogeneous geographic areas, following the succession already indicated in the Introduction and summarizing the main characteristic elements for each of them.

Zone of Jambil-Saidu

A1. Gharasa

The stupa comprises 5 storeys, the 1st rectangular in plan supporting the circular 2nd, 3rd and 4th storeys (the 3rd set back with respect to the 2nd) and the 4th having the function of drum; from the latter springs the raised hemispherical dome where, in the core, there is a double cavity with a rectangular plan. It has a double stairway on the longitudinal axis running westward and corresponding to the 1st and 2nd storeys, to which it is linked by a projection. The double stairway encloses another one of rough workmanship, possibly used as a work site.

The height of the individual storeys (wall and cornice) decreases with increasing height.

A2. Jurjurai

The stupa comprises 4 storeys, the 1st rectangular in plan, the 2nd and 3rd circular and progressively set back, the 3rd having the function of drum, with the coping slabs of the base and cornice missing, and the 4th comprising the raised dome.

The three storeys are decorated with pilasters with scotia type base, shaft with capital and modillion. They have steps along the longitudinal axis to the E corresponding to the 1st and 2nd storeys, to which they are connected by means of a projection, which is also decorated with pilasters in the internal and external corners in the 1st storey and only in the inner corner of the 2nd storey. Of particular interest is the projection with side walls splayed slightly outwards.

The measures of the storeys and mouldings decrease with increasing height.

It differs from the Stupa of Gharasa in its overall conception and the richness of its elements and is practically the same as the Stupa of Loebanr in its measures, overall layout and masonry construction techniques.

A3. Loebanr

The stupa stands on a double platform and its stairway is aligned with the longitudinal axis pointing westward both where it corresponds to the platforms and to the 1st and 2nd storeys, gradually narrowing towards the top starting from the double platform; likewise, also the measures of the storeys and mouldings decrease with increasing height. The highly peculiar elements characterizing it are a small room made under the first stairway and a small stupa incorporated in the core at the height of the 2nd storey: it was unfortunately not possible to determine the springer of the latter.

In its measures, layout and construction technique it closely resembles that of Jurjurai, from which it is not very far away, so that both could be defined as at least the result of the same construction conception.

A4. Arapkhanchina

On a large terrace with slight differences in level a group of monuments are crowded together; some no longer exist (stupa IV), others are badly deteriorated, and others again are in better conditions (stupas II and VI) and their reconstruction is therefore possible.

The stupa II, rectangular in plan, conserves only two gradually receding circular storeys: the 2nd and the 3rd; it may be considered that the latter was the drum from which the dome springs. The double stairway on the longitudinal axis connected to the 1st and 2nd storeys faces E. It has a torus type base and nothing is left of the cornice, which was perhaps of the ovolo and reverse cavetto type.

Although the stairway is in any case smaller there was clearly a possible link with the Stupa of Gharasa.

Overall note should be taken of the contemporary use (or use in subsequent restorations) of two building techniques: the so-called ashlar technique, with

Conclusion

talcoschist blocks used in the two lower storeys, and blocks and small slabs of schist in the upper ones.

Stupa VI, in particular, has the same layout as but smaller proportions than stupa II. It has a square-plan 1st storey and probably a stairway on the E side. Further useful information comes from the torus type base (2nd storey), the ovolo and reverse ovolo type cornice, lacking roofing slabs (3rd storey, drum). The core of the stupa is conserved over practically the full height (which is unusual), with a section of the lower vertical wall of the raised dome (h. 0.96), the centre of which in the upper line of this band represents the centre of the hemisphere; this might well give us a clue to explain the presence of a hemispheric profile also in the other stupas — and therefore in the relative reconstructions, even though it is no longer conserved in them.

Stupa V has a square plan like stupa VI, with a stairway on the S side, a limited size projection and a circular storey above. The internal structure it displays, which was originally not visible, is the same as the two storeys; the lower one in particular was stepped like that of the lower wall of the stupa (?) I.

Also stupa III has a square plan, perhaps with a stairway on the E side and an internal wall in the 2nd storey.

Overall, all these stupas considerably enrich the typology. Although their chronological succession cannot be determined with any accuracy, they may nevertheless be deemed to refer to a comparatively distant era: their simple structure supports this hypothesis and the ashlar and semi-ashlar techniques using large precisely dressed blocks could be considered valid elements of corroboration.

A5. Great Stupa (GSt.) of Butkara I

Situated on the plain land near the river — in Period 3 with F4 — more indicative of its long and complex development, it was built of talcoschist using the ashlar technique and is circular in plan with four stairways aligned with the axes. It has a railing running round the edge of the 1st storey starting from the stairway; the 2nd storey is set back and the size of the upper drum and dome cannot be determined. This can be considered a special case compared with all the others owing to its circular plan of ancient Indian tradition.

A6. Saidu Sharif I

In the Saidu Valley, built of talcoschist using ashlar technique. The 1st storey is rectangular in plan, with no pilasters, a stairway aligned along the longitudinal axis to the N and a railing continuing along the upper edge of the 1st storey; a 2nd storey, circular in plan, is set back and has steps aligned along the longitudinal axis. In the

four corners of the first storey there were columns with pedestal and Gandharan-Persepolitan capital.

A7. Shnaisha

At the end of the same valley lies this stupa with its rectangular plan and two set back circular storeys, the upper one identifying the drum of a composite dome. It still contains the empty recess meant to receive the protruding slabs at the base of the raised dome. It has a double stairway aligned with the 1st and 2nd storeys and all three bodies are decorated with pilasters.

Zone of Barikot

A8. Shankardar

To those travelling S from Mingora this large stupa comes into view with the lower part worn away. It has been partly reconstructed and has one rectangular storey with a set back 2nd storey; both storeys have stairways and pilasters with scotia type base, Gandharan-Corinthian capital and modillion, just like also the 3rd storey which is set back even further. The latter has a scotia type base, architraved cornice with brackets ending in a reverse ovolo lacking roofing slabs, which identifies it as a drum. From this springs the composite dome, raised by a transition storey curving inwards and closed at the top by a row of slabs. Overall it is reminiscent of the Stupa of Shnaisha.

A9. Amluk Dara

The large stupa is partly quite similar to the the preceding one of Shankardar.

Erected on a base having a horizontal level floor on the southward sloping ground are the rectangular 1st and the 2nd cylindrical one; both have stairways facing N with a torus type base and architraved cornice with reverse cavetto, ovolo and brackets with reverse ovolo and roofing slab. Set even further back is the drum with the same base size, smooth wall and cornice with cavetto, ovolo and brackets and reverse ovolo lacking covering slabs; perhaps originally a niche at the top of the steps below. The diameter of the composite dome is equal to that of the 2nd storey; it consists of a lower transition element with cornice and brackets with reverse cavetto and ovolo between two fillets and an upper raised dome, almost intact, with with a row of protruding header and stretcher blocks. The latter then display one or two square recesses closed by small slabs and thus not visible which have non determinable function although perhaps connected to work on the building site.

This resemblance to the Stupa of Shankardar is lost in the upper part owing to

Conclusion

the smooth drum, the possible presence of a niche, the type of cornice closing the drum and that between the transition storey and the raised dome.

It must be stressed that all these details concerning the cornice are in any case important with regard to the overall distribution of the volumes and the general view of the architecture as in this stupa in particular they are displayed in a singular fashion that is not found elsewhere.

A10. Abbasahebchina

A full picture of an entire sacred area is provided by the Abbasahebchina complex standing on the two terraced banks of a torrent. Monuments of various kinds remain: thus grouped together and comparatively well conserved, they allow an immediate overall assessment. Stupa A seems to be the most important one; it is linked by a bridge-dam spanning the torrent and connecting it to the rest of the settlement at the foot of the mountains to the W, where the stupas B and C and other monuments lie: vihara of a different type and to the N various rooms of the actual monastery. Stupa A has a rectangular 1st storey and progressively set back 2nd and 3rd storeys. The 1st and 2nd storeys have a stairway and the 3rd storey acts as a drum and lacks the coping slab on the ovolo of the terminal cornice. This is followed, with the same diameter, by the composite dome provided with a transition element that recedes with increasing height, the row of protruding slabs and the raised dome itself. The 1st and 2nd storeys have scotia type base and architraved corbelled cornice, and are decorated by pilasters with scotia type base, shaft, capital and modillion. In the 3rd storey, the base of both the storey and the pilaster are of the torus type.

Stupas B and C repeat the layout and general form of stupa A and they differ only in a few details (slabs protruding between the pilasters of the 1st storey of A at the height of the bases; scotia type base in the 2nd and 3rd storeys of C; two stairways aligned with the longitudinal axis in B and a single stairway in C, all oriented toward the N).

The stupa measures do not differ appreciably, and there is little difference in the number of pilasters: including the corner one, stupa A has 8 in the 1st storey, 22 in the 2nd, 24 in the 3rd; in stupa B there are 7 in the 1st storey, 22 in the 2nd, 24 in the 3rd; in stupa C there are 7 in the 1st storey, 24 in the 2nd, 24 in the 3rd. In all the pilasters of the 2nd and 3rd storeys lie in the same axis, unlike those related to the walls of the 1st storey.

Large patches of thick and strongly adherent plaster have been conserved everywhere; it has been used to shape mouldings and decorations of the various structures: shaft grooving; dentils or ovolos in the modillion and the architrave; in the modillion recess a leaf has been applied subsequently on the first coating of

plaster and later graffito to ensure stronger adhesion. Coloured lines are still visible on the plaster to outline the mouldings. Traces of phytomorphic decoration are still visible in the lower zone of the 1st storey of stupa A, and in the wall between the pilasters of the 3rd storey of stupa B there is again a stretch of painted images.

As far as the construction technique used for the individual stupas is concerned, also in this case a previously observed system of rustic internal structures based on decorated exterior coatings was used.

With regard to the overall layout, the terrace work of stupa A allows the stupa to be linked to the monuments on the left bank of the torrent; stupas B and C have a stairway facing N, perhaps to invite entry to the sacred area precisely from this side of the complex, as the existence of the monastery seems to confirm.

Lastly, it is important to stress that the three stupas are obviously homogeneous. This allows us to link them if not to a single project at least to a single construction effort. However, it is difficult to establish the timing starting from the selection of the sites and through its various chronology. In view of its exceptional location, vihara F was possibly built later (see B1.1). The area however abounds in other monuments: vihara D, large and particularly well conserved, smaller viharas and above all various dwelling buildings on the W slopes of the mountain and at the narrow mouth of the valley (see C1).

All. Tokar Dara

The massive stupa dominates in full view the beginning of a side valley branching off that of Najigram. It has a rectangular 1st storey, two gradually receding circular upper storeys and, with the same diameter, the 4th storey which serves as a drum to the raised dome. The base moulding of the first three storeys is over the torus type with a cornice with ovolo, reverse cavetto and brackets enclosed between reverse ovolo and coping slabs. The 4th storey, the drum, has no base and has a thin corbelled cornice, with reverse ovolo and no coping slabs. Corresponding to the 1st and 2nd storeys is a double stairway aligned with the longitudinal axis; at its point of arrival there is a niche. Below the stairway projection of the 1st storey a rectangular cell with a dome-shaped roof has been constructed.

Noteworthy is the structure of the upper section of the corbelled cornice of the 3rd storey, abutting the base of the wall of the 4th storey where the slabs are now inserted above the fillet and the reverse ovolo, exceptionally lacking coping slabs. Free columns once stood above the corners of the rectangular 1st storey. This and other characteristics are indicative of the links with other stupas already examined.

It is connected to different buildings. It is surrounded by lesser buildings; to the rear is the monastery, an enclosed vihara on a base and with a stairway, and in the valley behind a rich complex of sacred buildings and dwellings, also provided

Conclusion

with a system of canals for water supply. This complex, together with that of Abbasahebchina, was investigated in detail by Piero Spagnesi starting in 2004 (see B1).

A12. Barikot

Two large stupas (A and B), now reduced to a pile of debris, stood close together on two terraces near Barikot, at the beginning of the vast plainland on to which the valleys leading in from the E open.

They perhaps had the same structural characteristics; the first was better conserved, with the composite dome formed by the lower transition storey, lacking a base and receding slightly with increasing height, and the raised dome separated from the preceding storey by the typical protruding slabs.

Zone of Thana

A13. Top Dara

The stupa stands on a platform at the rear of a flat area near Haibatgram (Thana). It has a rectangular 1st storey with scotia type base mouldings, architraved cornice with cavetto and reverse ovolo, stairway to the E and walls with 8 pilasters per side, each with scotia type base, shaft, capital and modillion. The same moulding layout is found on the gradually receding cylindrical 2nd and 3rd storeys, each having 18 aligned pilasters between them. The 3rd storey, lacking coping slabs on the reverse ovolo of the cornice, is the drum serving as springer for the composite dome. A 4th storey, receding as it rises, serves as a transition element with the 5th storey; the dome itself, is raised and perhaps lacks protruding slabs (an unusual absence).

Inside the gap splitting the stupa into two parts from top to bottom the impression left by a small monument enclosed in the core is visible.

Zone of Gumbatuna

A14. Gumbatuna

The sacred area of Gumbatuna lies on the right bank of the Swat river. The stupa has a rectangular 1st storey with torus type base moulding and cornice with ovolo and reverse cavetto, itself closed by a reverse ovolo and coping slabs. The same mouldings are repeated in the gradually receding cylindrical 2nd and 3rd storeys; in particular, in the 3rd storey the cornice coping slabs are missing. The 4th storey (the drum), with the same diameter as the preceding one, lacks the base and has a low corbelled cornice with reverse ovolo and lacks coping slabs; it has a raised dome.

To the N there is a single stairway aligned along the longitudinal axis and there are free standing columns in the corners of the 1st storey.

As in Tokar Dara, also here the 4th storey lacks the base and has a very low corbelled cornice with reverse ovolo, lacking coping slabs as in the 3rd storey below. In this case the thin corbelled cornice of the 4th storey might have served the decorative function that is usually typical of the protruding slabs in a composite dome.

Typological and Chronological Observations

Typology

These brief descriptions highlight the more significant technical and formal characteristics of each monument.

In the zone of Jambil-Saidu, there are two main types in the area of Arapkhanchina: type 2 given by stupa II, with rectangular 1st storey and two gradually receding cylindrical storeys, raised dome and double stairway aligned with the longitudinal axis; and type 3 identified from stupas III, V and VI, square in plan, two gradually receding cylindrical storeys and dome with a single or no stairway along the longitudinal axis. The rectangular type 2, as marked by stupa II, in the stupas of Jurjurai and Loebanr is enhanced with pilasters in all the storeys, thus representing a type 4. At Loebanr in particular there is also a cell beneath the stairway and the core enclosed a small stupa. Type 5 is represented by the Stupa of Gharasa, with its additional cylindrical storey equal in diameter to the 3rd storey and the raised dome.

One completely different type – type 6 – is that of the Stupa of Saidu Sharif I. Conserved in the rectangular 1st storey and in the set back cylindrical 2nd storey, it has a double stairway aligned along the longitudinal axis and delimited by a railing running round the plane of the 1st storey; it has free standing columns in its corners; in the reconstruction its upper part has been rendered on the basis of similarity with the stupas of Tokar Dara and Gumbatuna. It thus has a double cylindrical storey of equal diameter from which the raised dome springs.

The presence of the railing might suggest the Great Stupa 3, F4 of Butkara I. However, the plan, stairs and masonry construction techniques used in the latter indicate it as a unique case (1), to a certain extent of importance as the beginning of a whole typological series (type 1).

The Stupa of Shnaisha is indicative of type 7. The first three storeys are punctuated by pilasters, as in the stupas of Loebanr and Jurjurai. In the 3rd storey there is an important detail regarding the dome, which is of the composite type, as is shown by the slightly inward curving transition element in the upper part and

Conclusion

above a recess due to a row of protruding slabs.

Also belonging to this type is the massive Stupa of Shankardar, the largest, and the stupas A, B and C of Abbasahebchina, smaller and with two stairways (stupa A, B) and a single stairway (stupa C), and stupas A and B of Barikot. The Stupa of Top Dara may be considered a further variant of type 7 owing to the absence of the typical row of protruding slabs in the composite dome (type 7 variant).

It has already been mentioned that the Stupa of Tokar Dara recalls that of Gumbatuna, which itself was used to orient the reconstruction of that of Saidu Sharif I and the Stupa of Gharasa, which however lacks corner columns. The latter is again reminiscent of the Stupa of Loebanr owing to the presence of a room under the stairway (absent in Gumbatuna): it thus also represents a variant of types 4 and 5.

Lastly, the Stupa of Amluk Dara is certainly comparable to that of Shankardar owing to its large size. It has a 1st and 2nd storey with stairways and is decorated with pilasters; these are followed by two storeys of equal diameter: the 4th in particular lacks a base, and has a cornice and a structure overlying the base of the raised dome that is probably connected with the work but not visible at the end of construction. There are pilasters only on the first two bodies and their absence in the 3rd means that it can be classified as type 8.

Overall, in the Barikot area, it should be emphasized that there is a significant presence of stupas with a composite dome, together with a certain number of variants thereof.

Zones of Jambil-Saidu and Barikot-Thana-Gumbatuna Compared

On the basis of such elements as plan, number of storeys, dome type, presence or absence of pilaster decoration of the surfaces and other ancillary elements (corner columns, railing) several observations may be proposed.

In the zone of Jambil-Saidu there is a greater simplicity of the lower storeys, square or rectangular in plan, lacking pilasters and with hemispherical or raised dome. These aspects are rendered more obvious by the case of the Great Stupa of Butkara I, circular in plan according to the Indian tradition, but in which also a classical influence is visible in the railing. Outstanding among the others are the stupas of Jurjurai and Loebanr, both with a rectangular lower storey and the two cylindrical upper ones gradually set back and decorated with pilasters. At Shnaisha, in addition to the pilasters there is also a composite dome. In the whole Barikot-Thana-Gumbatuna zone the stupas display the widespread characteristic of pilaster decoration on the three lower storeys and the composite dome. A variant of this type of dome is found in the Stupa of Top Dara, which lacks protruding slabs. The pilaster decoration is found also in the 1st and 2nd storeys of the massive

Stupa of Amluk Dara, itself a peculiar type owing to the various superimposed storeys. At Tokar Dara and Gumbatuna — already cited in the comparison with the Stupa of Saidu Sharif I — we find the return of undecorated storeys, with the drum separated from the dome by a cornice.

If we then observe all the monuments in the two zones, we find that each one makes a different specific use of the various types. In the zone of Jambil-Saidu we find a certain degree of simplicity in the overall shapes and in the individual elements, together with a use of pilaster decoration in the two well known cases, in addition to the isolated type of Shnaisha with decoration and composite dome. The reciprocal vicinity of the two monuments of Jurjurai and Loebanr could account for the repetition; the different type of Shnaisha could be explained by its provenance from the zone of Barikot, which is close by and accessible along the tracks crossing the mountains in the background. Again, the zone of Barikot displays very different aspects, with a specific and widespread type with pilasters and composite dome, which overall is richer and more complex also in the construction methods used. The general appearance of this type of stupa might indicate they belong to a later period than the former.

It is in any case interesting to note that in general a reciprocal similarity among several monuments may be the result of their vicinity (Jurjurai and Loebanr in the Jambil-Saidu zone) or due to the fact that they possibly belonged to sacred areas that were linked in some way (Abbasahebchina and Barikot in the Barikot zone).

In this very concise framework some mention should also be made of several ancillary elements: the niche on top of the last flight of steps (at Amluk Dara and Tokar Dara), the small stupa incorporated in the core of the larger one at the time of the latter's construction (Loebanr, Top Dara), the room with hitherto not fully defined function under the first flight of steps (Loebanr, Tokar Dara). Just as it should not be overlooked that the links between all these elements with the typological patterns outlined above in any case is never as simple might appear at first sight.

In conclusion, it should be noted that in the simplicity and repetitiveness of the elements comprising these architectures (rectangular base, cylindrical storeys, domes) each one displayed a substantial diversity that was achieved by means of small subtle differences of detail that had a decisive effect on their overall appearance, on each occasion determining ever new characteristics.

Chronology

The chronology of these types of architecture and related monuments is extremely uncertain. It should nevertheless be borne in mind that the dating of a monument is never strictly related to the appearance of the type to which it belongs but depends on its construction; moreover, the duration in time of the type under consideration is practically impossible to determine. Nevertheless, a few useful indications may be drawn.

One may be drawn from the Great Stupa of Butkara I, mainly from GSt.3 on (GSt.3 with F3, GSt.4/1 on F3; Kujula Kadphises type, Huviska). It is a fact that GSt.3 in particular, with the paving F4, may be attributed to the Saka-Parthian era (c. 20 A.D.) (Errington 1999-2000; Faccenna 2002, 2003, 2007). Again, the Stupa of Saidu Sharif I, with its double steps along the longitudinal axis and corner columns dates to about the mid 1st cent. A.D. (Faccenna 1995a: 155-59. The stupas of Tokar Dara and Gumbatuna may be likened to it. Lastly, the Stupa of Shnaisha – with its rectangular and cylindrical storeys and pilasters and composite dome with protruding slabs, the recesses of which still remain, may be attributed to the period of Huviska: this is a significant fact in view of the widespread presence of this type of dome and of pilaster decoration in the Barikot zone, even if in the case of Top Dara the final row of protruding slabs is actually missing in the composite dome.

B. Viharas

Zone of Barikot

B1.1. Vihara F of Abbasahebchina

Built on top of a podium, it has slightly diverging side walls sloping inwards; and front opening occupying the full width of the wall, externally a double roof covering – the lower one consisting of folds and the upper one dome shaped. It is reminiscent of the buildings of the Takht-i-Bahi court.

B1.2. Small vihara, rectangular in plan.

B2. Vihara of Gumbat

Standing massive on a tall podium, quadrangular in plan, with steps and projection, it has a cell with double ogival roof covering and corridor around the perimeter with ogival vault, double external roof covering and an entrance that tapers slightly as it rises; the lower external roof covering has four curved folds and the upper one has an elongated dome. In the walls there is an interesting and effective daytime and

nighttime lighting system for illuminating the interior. The solution adopted for the transition area of the corners of the corridor vault is not easy to determine.

B3.1. Double vihara of Kanjar Kote

Two adjoining cells, completely open towards the front, form a single rectangular-plan building standing on a single podium with a single truncated pyramid shaped roof covering with four oblique folds. Each cell has its own four fold pavilion vault, a new type of roof covering for Swat.

B3.2. Vihara, circular in plan.

Zone of Gumbatuna

B4. Vihara of Gumbatuna

Circular in plan, like the similar vihara of Kanjar Kote, it stands on a base with front opening and raised dome internal vault and external roof covering with inclined flat folds.

Some Overall Considerations

The characteristics of several of these monuments will now be briefly outlined. For the building B2 of Gumbat, standing on a tall quadrangular podium with cell and corridor running around the perimeter, some comparisons may be made and there is a certain amount of documentation. Also in the Swat Valley it suggests the Great Vihara of Butkara I, no doubt the earliest example of this type which is contemporary with GSt.3-F4, together with which it forms a system of two architectural poles within the renewed sacred area (Faccenna 1980-1981: 151-60, figs. 52, 56; 2001: 164-66, figs. 48-49). Perhaps it is also at Tokar Dara, in the sacred area S of the monastery (Behrendt 2003: figs. 112-113; Spagnesi 2006).

This same type, although in more complex forms, is found also in several buildings in Taxila and Hadda, of long-standing Bactrian tradition (Franz 1981, 1984). Two reliefs, possibly dating to the 2nd cent. A.D. (Foucher 1905-51: fig. 41; Faccenna 1995a: pls.283a, 285c from Gumbatuna; Khan Ashraf 1993: fig. 29), display a striking similarity with the possible reconstructed perspective of the vihara of Gumbat, even though, in this specific case, the dome, which still exists, seems to be higher or to have a more elongated profile, in particular when compared with the Gumbatuna relief.

Unusual, and so far unique as far as we know, is the type of double vihara with pavilion vault of Kanjar Kote (see B3.1).

C. Dwelling units

Zone of Barikot

C1. Dwelling unit of Abbasahebchina

It has an elongated rectangular plan and is composed of two rooms separated by a large anteroom and facing on to a porch; an external stairway on one of the two short sides of the building led up to a floor above.

In the valley, this typological pattern is extremely widespread: it is found at Saidu Sharif I, Abbasahebchina and Tokar Dara, as well as also in areas outside Swat (at Takht-i-Bahi, Jamalgarhi).

Buddhist Architecture in the Swat Valley: several final notes

The Buddhist monuments, in particular the medium and large size ones described herein, never stood in isolation. They were surrounded by other small ones in different scales, as have been shown by both the scientific and the emergency and illegal excavations.

The planning of each sacred area started with the choice of the site, as justified by various reasons: its sacred nature; venerable antiquity (as at Butkara I); practical considerations, whether it was on the plain or at different heights, and thus the need for terraces or at the top of mountain passes; its relationship with water (to be solved by means of dams, bridges, irrigation canals), with the more important roads, with neighbouring inhabited areas even when in the vicinity of burial areas of previous ages (Butkara II, Saidu Sharif I). As a result of all this and in order to adapt to these conditions, the solutions varied widely and were always specific to a given site.

Then came the layout of the principal monument (stupa or vihara) in the sacred area. Overall its most common position seems to have been either central or along a particular axis, although always with other constructions nearby and as a function of allowing as full as possible a side view: its position and the direction of access were also determined by these factors. The lateral view of the monument was enhanced by the colours, the gilding and the pictorial and sculptural decorations. Moreover, each principal architectural form was often projected against an unencumbered sky and not against an artificial preconstructed background so as to make it seem larger than it was. It is not impossible that the use of a base (the 1st storey, quadrangular in plan) was related to this type of view, that is, as a function of an enhanced visibility of what was originally a stupa composed solely of cylindrical storeys and dome, that is, of essentially restricted forms. Quadrangular bases (like the 1st storey) had been tried out previously only in small size stupas (Butkara I).

The sacred complex appeared already in the distance in such a way as to attract the worshipper with an immediate view of the principal monument, standing in the forefront and open to the faithful. It was located on the plain, on the terraced hillsides or at the mouth of lateral valleys, never in the larger valleys, and even today they penetrate among the mountains, shrinking appreciably in size. At their rear, at different heights, stood the monastery and specific areas with different buildings; further back and on the outskirts stood the dwelling units and other lesser sacred buildings. One concise version of this type of layout is the sacred area of Saidu Sharif I. A more complex version may be found, as far as we know, in the sacred centre of Abbasahebchina and above all in the highly complex one of Tokar Dara.

The entire complex blended in with the surrounding nature. From this it drew its charm, importance and beauty – all elements that are believed to have been taken into consideration both in the original plans and subsequent extensions.

This type of layout normally consisted of three main parts: the terrace of the stupas (with the main stupa or vihara and the lesser stupas and viharas), the monastery, and the dwelling units. The first of these was designed for the worshippers, the second for the community of priests and the third, virtually filtered through the two preceding zones, was for those living an isolated, separate and perhaps contemplative life. Everything was functional to a monkish community in that it reflected a religious conception deriving from a specific spiritual and philosophic attitude which led to a social organization that spread widely, always the same, as is shown by the uniformity of the constructions that is found in practically all the areas where there are visible structures.

In all this both the community and the architects found satisfaction for the needs of their worship and their life in a complex process of creation and construction following rules that were not always the same: to appreciate this *a posteriori* it is first necessary, in any and every case, to proceed to the chronological definition of each single organic set of architectural types; then, to set them in a time frame starting from their origins and throughout their, often radical, transformations. This no doubt demands the extension of complete archaeological investigations also in neighbouring areas. In our case, this would mean leaving the Swat Valley and the simple documentary presentation of isolated and unexcavated monuments (stupas, and to a much lesser extent, viharas and dwelling units) carried out hitherto in an extremely strenuous effort precisely because of their present conditions. It is as a function of all this that the in-depth archaeological investigation of the sacred centre of Abbasahebchina and above all that of Tokar Dara is deemed to be particularly interesting and it is towards this kind of knowledge that the wide-ranging work of description and surveying, here barely outlined, will be directed. In the Mission programmes this work will be carried out in future campaigns by P. Spagnesi and

Conclusion

other researchers: only in this way will it be possible to gain a complete overview of the architecture and life style of a great Buddhist sacred centre and, last but not least, complete a programme launched by Domenico Faccenna when he undertook his studies in Swat, something that is already taking place (Spagnesi 2006).

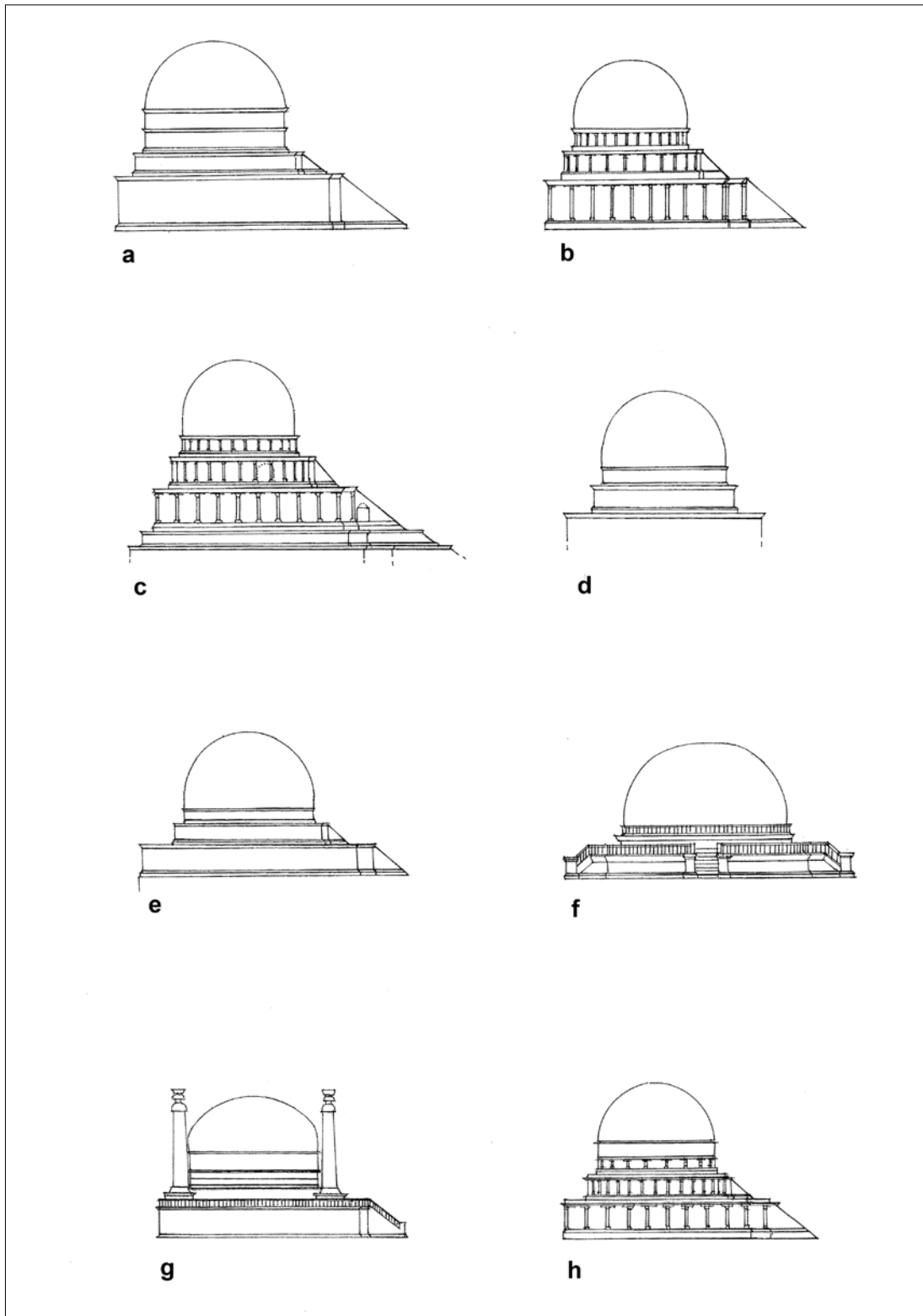

Fig. 530. Zone of Jambil-Saidu. Jambil Valley: *a.* (1) Gharasa: type 5. *b.* (2) Jurjurai: type 4. *c.* (3) Loebanr: type 4. *d.* (4) Arapkhanchina VI: type 3. *e.* (4) Arapkhanchina II: type 2. *f.* (5) Butkara I (GSt. 3, F4): type 1. Saidu Valley: *g.* (6) Saidu Sharif I: type 6. *h.* (7) Shnaisha: type 7.

Conclusion

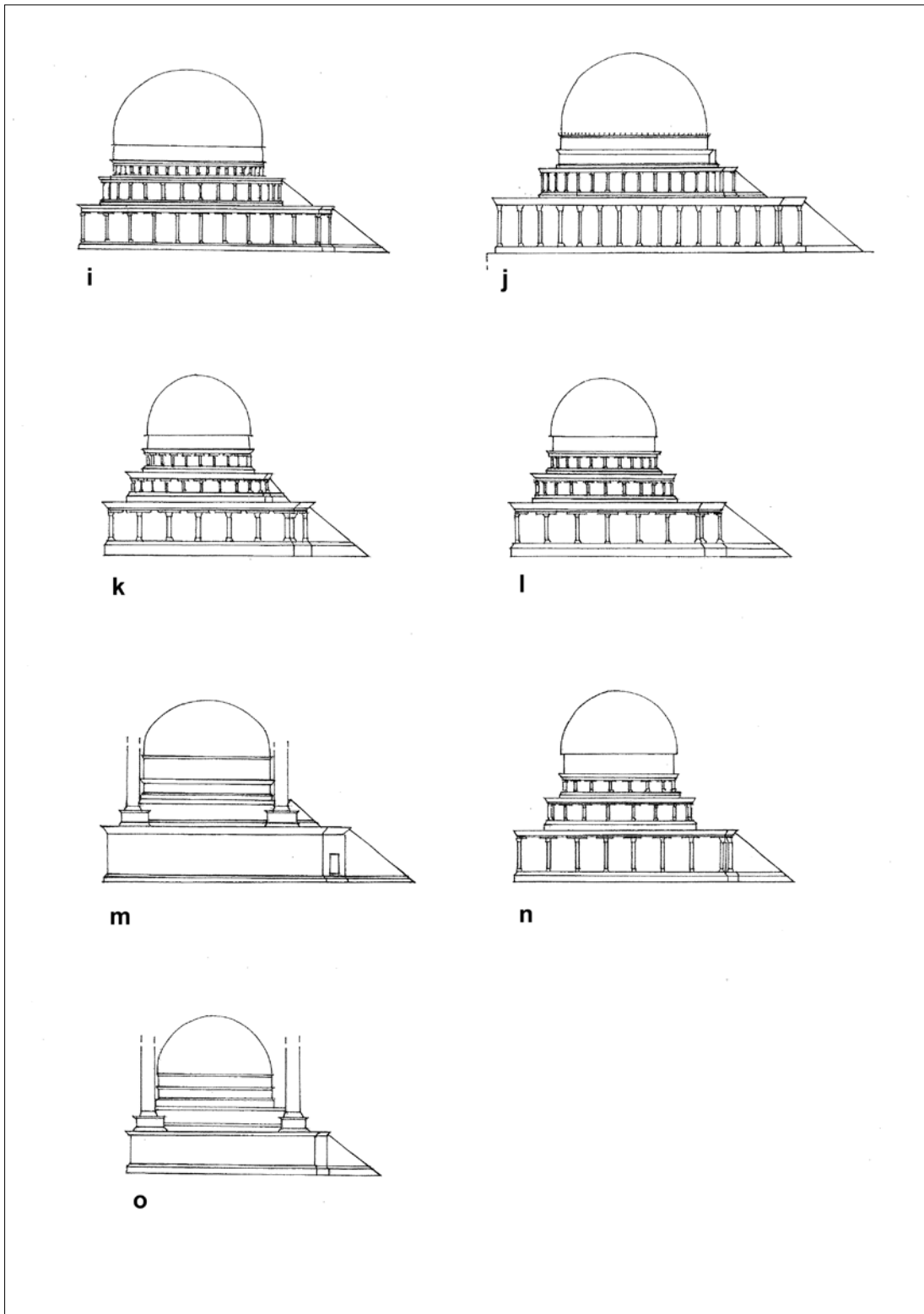

Fig. 531. Zone of Barikot-Thana-Gumbatuna. *i.* (8) Shankardar: type 7. *j.* (9) Amluk Dara: type 8. *k.* (10) Abbasahebchina A: type 7. *l.* (11) Abbasahebchina C: type 7. *m.* (12) Tokar Dara: variant of types 4 and 5. *n.* (13) Top Dara: variant of type 7. *o.* (14) Gumbatuna: variant of types 4 and 5.

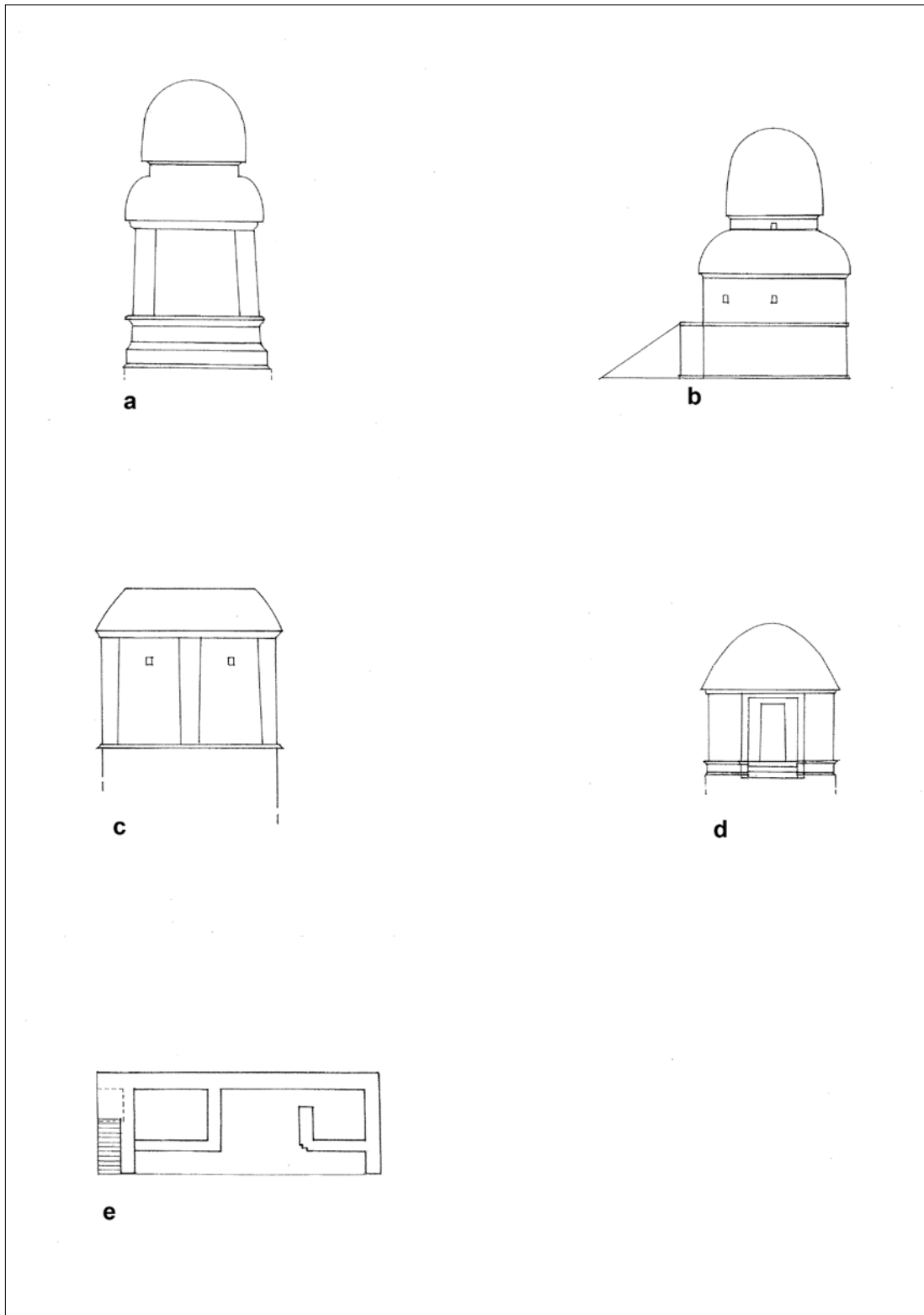

Fig. 532. Vihara. *a.* (B1.1) Abbasahebchina: Vihara F. *b.* (B2) Gumbat. *c.* (B3.1) Kanjar Kote: double vihara. *d.* (B4) Gumbatuna: circular vihara. Dwelling unit. *e.* (C1) Abbasahebchina: dwelling unit.

References

- Ali, I. & M. Zahir (2005) *Guide to Peshawar Museum, Peshawar*. Directorate of Archaeology and Museums, Government of NWFP Peshawar. Peshawar.
- Badshah Sardar (2005) *Buddhist Rock Carvings in the Swāt Valley*. Islamabad.
- Badshah Sardar & Saleem-ul-Haq (1997) Gandhara: A Buddhist School of Art. *Journal of Central Asia*, XX, 1, pp. 151-68.
- Barger, E. & Ph. Wright (1941) Excavations in Swat and Exploration in the Oxus Territories of Afghanistan: A Detailed Report of the 1938 Expedition. *Memoirs of the Archaeological Survey of India*, 64. Calcutta.
- Beal, S. (1884) *Si-yu-ki, Buddhist Records of the Western World*. London.
- Behrendt, K.A. (2004) *The Buddhist Architecture of Gandhāra. (Handbook of Oriental Studies, section two, India, vol. 17)*. Leiden-Boston.
- Brown, P. (1976⁷) *Indian Architecture (Buddhist and Hindu Periods)*. Bombay. (1st ed. 1967).
- Dani, A.H. (1965-66) *Ancient Pakistan*, II.
- Dani, A.H. (1968-69) Excavation at Andandheri. In A.H. Dani, ed., *Chakdara Fort and Gandhara Art. Ancient Pakistan*, IV, pp. 33-64.
- Deane, H.A. (1886) Note on Udyāna and Gandhāra. *Journal of the Royal Asiatic Society*, pp. 654-75.
- Errington, E. (1999-2000) Numismatic Evidence for Dating the Buddhist Remains of Gandhara. *Silk Road Art and Archaeology*, 6, Papers in Honour of Francine Tissot, pp. 191-216.
- Faccenna, D. (1980-81) *Butkara I (Swāt, Pakistan) 1956-1962*. Istituto Italiano per il Medio ed Estremo Oriente, Centro Scavi e Studi Archeologici in Asia, Reports and Memoirs, Series Maior, III, 1-5.2. Rome.

- Faccenna, D. (1986) Lo *stūpa* a colonne dell' Area Sacra buddhista di Saidu Sharif I (Swāt, Pakistan). In G. Brucher et al., ed., *Orient und Okzident im Spiegel der Kunst. Festschrift Heinrich Gerhard Franz zum 70. Geburtstag*, pp. 55-80. Graz.
- Faccenna, D. (1995a) *Saidu Sharif I (Swat, Pakistan), 2. The Buddhist Sacred Area. The Stūpa Terrace*. Istituto Italiano per il Medio ed Estremo Oriente, Centro Scavi e Ricerche Archeologiche-Istituto Universitario Orientale di Napoli, Reports and Memoirs, Series Maior, XXIII, 2. Rome.
- Faccenna, D. (1995b) A Relief in the Lahore Museum Showing a Columned Stupa. *Lahore Museum Bulletin*, VIII, 2, pp. 1-13.
- Faccenna, D. (2001) *Il fregio figurato dello Stūpa principale dell'area sacra buddhista di Saidu Sharif I (Swat, Pakistan)*. IsIAO, Reports and Memoirs, XXVIII. Rome.
- Faccenna, D. (2002) Il complesso buddhista di Butkara I: nascita e sviluppo. In P. Callieri & A. Filigenzi, eds., *Il maestro di Saidu Sharif. All'origine dell'arte del Gandhara*. Ministero per i Beni e le Attività Culturali, Museo Nazionale d'Arte Orientale - Istituto Italiano per l'Africa e l'Oriente, pp. 107-12. Roma.
- Faccenna, D. (2003) The Butkara I Complex: Origins and Development. In *At the Origin of Gandharan Art. The Contribution of the IsIAO Italian Archaeological Mission in the Swat Valley Pakistan. Ancient Civilizations from Scythia to Siberia*, 9, 3-4, pp. 277-86. Leiden-Boston.
- Faccenna, D. (2006) Reconstruction of a Sculptural Complex in the Buddhist Sacred Area of Butkara I. *East and West*, 56, 1-3, pp. 177-94.
- Faccenna, D. (2007) The Artistic Centers of Butkara I and Saidu Sharif I in the Pre-Kuṣhāṇa Period. In D.M. Srinivasan, ed., *On the Cusp of an Era: Art in the Pre-Kuṣāṇa World*. (Relazione presentata al Museo Nazionale d'Arte Nelson-Atkins nel Simposio Internazionale, 8-11 Novembre 2000, Kansas City, Missouri), pp. 165-99. Leiden-Boston.
- Faccenna, D. & A. Filigenzi (2007) *Repertorio terminologico per la schedatura delle sculture dell'arte gandharica. Sulla base dei materiali provenienti dagli scavi della Missione Archeologica Italiana dell'IsIAO nello Swat, Pakistan / Repertory of Terms for Cataloguing Gandharan Sculptures. Based on Materials from the IsIAO Italian Archaeological Mission in Swat, Pakistan*. Istituto Italiano per l'Africa e l'Oriente-Università di Napoli 'L'Orientale', Reports and Memoirs, New Series, V. Roma.
- Faccenna, D., A. Nabi Khan & I.M. Nadiem (1993) *Pāṇr I (Swat, Pakistan)*. Istituto Italiano per il Medio ed Estremo Oriente, Centro Scavi e Ricerche Archeologiche, Series Maior, XXVI, 1-2. Rome.

References

- Filigenzi, A. (2000) Marginal Notes on the Buddhist Rock Sculptures of Swat. In M. Taddei e G. De Marco, ed., *South Asian Archaeology 1997*. Istituto Italiano per l'Africa e l'Oriente, Serie Orientale Roma, XC, vol. 3, pp. 1065-85. Rome.
- Filigenzi, A. (2007) L'arte del Gandhāra. In A. Invernizzi, ed., *Sulla via di Alessandro da Seleucia al Gandhāra*, pp. 29-37. Milano.
- Filigenzi, A. (2014) *Art and Landscape: Buddhist Rock Sculptures of Swat/Uḍḍiyāna*. With contributions by L.M. Olivieri and P. Rockwell. Vienna (Austrian Academy of Sciences).
- Fincastle, the Viscount, M. & P.C. Elliott-Lockhart (1898) *A Frontier Campaign. A Narrative of the Operations of the Malakand and Buner Field Forces, 1897-1898*. London.
- Foucher, A. (1905-1951) *L'art gréco-bouddhique du Gandhāra*. Paris.
- Foucher, A. (1942) *La vieille route de l'Inde de Bactres à Taxila*. Mémoires de la Délégation Archéologique Française en Afghanistan. Paris.
- Franz, H.G. (1959) Ein unbekannter Stūpa der Sammlung Gai und die Entwicklung des Stūpa im Gebiet des alten Gandhāra. *Zeitschrift der Deutschen Morgenländischen Gesellschaft*, 109, pp. 128-47.
- Franz, H.G. (1965) *Buddhistische Kunst Indiens*. Leipzig.
- Franz, H.G. (1977) Der buddhistische Stupa in Afghanistan. Ursprünge und Entwicklung (Teil 1). *Afghanistan Journal*, 4, 4, pp. 131-43.
- Franz, H.G. (1980) Stūpa and Stūpa-temple in the Gandhāran Region and in Central Asia. In A.L. Dallapiccola, ed., *The Stūpa. Its Religious, Historical and Architectural Significance*, pp. 39-58. Wiesbaden.
- Franz, H.G. (1981) Ambulatory Temples in Buddhism and Hinduism. In H. Härtel, ed., *South Asian Archaeology 1979*, pp. 449-58. Berlin.
- Franz, H.G. (1984) Umgangstempel in Mittelasien und Indien. In J. Ozols & V. Thewalt, ed., *Aus dem Osten des Alexanderreiches. Völker und Kulturen zwischen Orient und Okzident, Iran, Afghanistan, Pakistan, Indien. Festschrift zum 65. Geburtstag von Klaus Fischer*, pp. 127-42. Köln.
- Higuchi, T. et al., eds. (1984) *The Exhibition of Gandhara Art of Pakistan*. Tokyo.
- Hobday, E.H.P. (1898) *Sketches on Servis during the Indian Frontier Campaigns of 1897-1898*. Bowden.
- Julien, S. (1857-1858) *Mémoires sur les contrées occidentales*. Paris.

- Khan, A. Nasir (2004) The Architectural Feature of Buddhist Site of Tokardara Najigram. *The Misulsa. The Art History Journal*, 23, pp. 302-16. (Reprinted in *Journal of the Pakistan Historical Society*, Karachi 2005).
- Khan, A. Nazir, L.M. Olivieri & M. Vitali (1995) The Recent Discovery of Cave Paintings in Swat. A Preliminary Note. *East and West*, 45, 1-4, pp. 333-53.
- Khan, F. A., ed. (1968) II. Conservation, Excavated Remains at Swat (1) Amlokudara stupa. Department of Archaeology and Museums in Pakistan. *Pakistan Archaeology*, 5, pp. 227-28.
- Khan, M. Ashraf (1993) *Buddhist Shrines in Swat*. Shaidu Sharif.
- Khan, M. Ashraf (1996) Excavation at Gumbatuna Stūpa (Swat). In Saeed-ur-Rehman, ed., *Archaeological Reconnaissance in Gandhara*. Department of Archaeology and Museums, Ministry of Culture and Sport, Government of Pakistan, pp. 96-106. Karachi.
- Khan, M. Ashraf & Tahira Saeed (1999) A Newly Discovered Stone Relic-casket from Shnaisha-Gumbat in Swat. *Lahore Museum Bulletin*, XII, 2, pp. 43-48.
- Khan, M. Ashraf & A.Gh. Lone (2004) *Gandhara. Geography, Antiquity, Art & Personalities*. Ravalpindi.
- Khan, M. Bahadur et al. (1999) *Malakand Agency. Archaeological Survey and Documentation of Sites and Monuments*. Preliminary Report, 1, Department of Archaeology and Museums, Government of Pakistan. N.p.
- Koutcha III = M. Hallade, S. Gaulier e Missione P. Pelliot, a cura di, *Koutcha, Douldul Aqour et Soubashi*, Paris III (illustrations 1967), Paris IV (text 1982).
- Kurita, I. (2003) *Gandhāran Art, I. The Buddha's Life Story. A Revised and Enlarged Edition*. Ancient Buddhist Art Series. Tokyo.
- Marshall, J. (1951) *Taxila*. Cambridge.
- Masson, Ch. (1841) A Memoir on the Topes and Sepulchral Monuments of Afghanistan. In Wilson 1841: 55-118.
- Nishikawa, K. (1986) *Gandhara. Preliminary Report on the Comprehensive Survey of Buddhist Sites in Gandhāra 1983, 1984*. Kyoto.
- Olivieri, L.M. (2003) *Bīr-koṭ-ghwaṇḍai Interim Report, I. The Survey of the Birkot Hills. Archaeological Map and Photographic Documentation*. Reports and Memoirs, Series Minor, VI. Roma.
- Olivieri, L.M. (2006) Outline History of the IsIAO Italian Archaeology Mission in Pakistan (1956-2006). *East and West*, 56, 1-3, pp. 23-41.

References

- Olivieri, L.M. & M. Vidale (2006) Archaeology and Settlement History in a Test Area of the Swat Valley. Preliminary Report on the AMSV Project (1st Phase). *East and West*, 56, 1-3, pp. 73-150.
- Qamar, Mian Said & M. Ashraf Khan (1991) Preliminary Report on the Archaeological Excavations of Buddhist Sites in Swat, N.W.F.P., 1989-90. *Journal of Central Asia*, XIV, 1, pp. 173-209.
- Rahman, A. (1993a) A Recent Development in Buddhist Archaeology in Pakistan. *South Asian Studies*, 9, pp. 105-8.
- Rahman, A. (1993b) Shnaisha Gumbat: First Preliminary Excavation Report. In *Professor Ahmad Hasan Dani Felicitation Volume. Ancient Pakistan*, VIII, pp. 1-113.
- Rahman, A. (2001) Some Remarks on Taddei's Review of Shnaisha. *Ancient Pakistan*, XIV, pp. 310-20.
- Raverty, H.G. (1863) An Account of Upper and Lower Suwát, and the Kohistán, to the Source of the Suwát River; with an Account of the Tribes Inhabiting Those Valleys. *Journal of the Asiatic Society of Bengal*, XXI, I to V, pp. 227-81.
- Raverty, H.G. (1878) *Notes on Afghanistan and Baluchistan*. London. (1st reprint Pakistan, 1976).
- Rhie, M.M. (2002) *Early Buddhist Art of China and Central Asia, 2. The Eastern Chin and Sixteen Kingdoms Period in China and Tumshuk, Kucha and Karashahr in Central Asia*. Handbook of Oriental Studies, section four China; vol. 12.2, text, illustration. Leiden-Boston-Köln.
- Spagnesi, P. (2006) Aspects of the Architecture of the Buddhist Sacred Areas in Swat. *East and West*, 56, 1-3, pp. 151-75.
- Stein, M.A. (1929) *On Alexander's Track to the Indus. Personal Narrative of Explorations on the North-West Frontier of India Carried Out under the Orders of H.M. Indian Government*. London. (Reprint New York 1972).
- Stein, M.A. (1930) *An Archaeological Tour in Upper Swāt and Adjacent Hill Tracts*. Memoirs of the Archaeological Survey of India, 42. Calcutta.
- Taddei, M. (1998) Some Remarks on the Preliminary Reports Published on the Shnaisha Excavations, Swat. *East and West*, 48, 1-2, pp. 171-88.
- Tarzi, Z. (2006) Deux rotondes bouddhiques d'Afghanistan. In P. Callieri, ed., *Architetti, capomastri, artigiani. L'organizzazione dei cantieri e della produzione artistica nell'Asia ellenistica. Studi offerti a Domenico Faccenna nel suo ottantestimo compleanno*. Istituto Italiano per l'Africa e l'Oriente, Serie Orientale Roma, C, pp. 275-310. Roma.

Tucci, G. (1958) Preliminary Report on an Archaeological Survey in Swat. *East and West*, 9, pp. 279-328. (Reprinted in G. Tucci, *On Swāt: Historical and Archaeological Notes*, Roma 1977, pp. 59-113).

Vidale, M. & L.M. Olivieri (2005) Najigram: i signori dell'acqua. *Archeo*, XXI, 8 (245), pp. 52-61.

Watters, T. (1904-05) *On Yuan Chwang's Travel in India 629-645 A.D.* Oriental Translation Fund Series, XIV. London.

Wilson, H.H. (1841) *Ariana Antiqua. A Descriptive Account of the Antiquities and Coins of Afghanistan, with a Memoir on the Buildings Called Topes by C. Masson, Esq.* London.